

DESIGNED ARCHITECTURAL LIGHTING





Engie UK (Formerly GDF Suez),
25 Canada Square, Canary Wharf
Electrical Design and Installation:
CCE Projects Ltd

Engie UK is a leading energy and services group, part of the well-established French multinational energy company. Engie is one of Britain's largest independent power producers, providing power and gas to thousands of UK businesses. They have recently occupied Level 20 of the 42 storey Canada Square tower building designed by César Pelli & Associates / Adamson Associates.

DAL provided a complex kit of Trimless Lightline 60 products with 4000K Ra80 LEDs. Plaster-in ceiling recessed luminaires were manufactured in specific lengths to the client's design specification. Modules for mounting in Barrisol stretched wall covering were also supplied.

DESIGNED ARCHITECTURAL LIGHTING

Designed Architectural Lighting, founded in 1983, has steadily established itself as one of Britain's leading independent companies in the design and manufacture of luminaires. DAL's philosophy is one of constant improvement. Our aim is to design, develop and manufacture products of the highest standard, whilst working closely with clients and their needs.

The range of products presented in this catalogue is the result of DAL's experience in integrating the requirements of architects, designers and engineers with the best in LED technology and materials. All luminaires are supplied with the latest developments in control gear ensuring the best in energy efficiency. DAL continually tracks and reviews the development of LEDs and offers the best and most reliable products available at the time.

Company procedures ensure that a consistency of product quality and respect for the environment is maintained by constant monitoring. This is recognised by DAL obtaining the ISO 9001 quality mark and ISO 14001 accreditation.

Designed Architectural Lighting products are designed and built in the United Kingdom to conform to the requirements EN 60598-1.

The primary purpose of the Waste Electrical and Electronic Equipment Regulations is to 'Reuse', 'Recycle' and 'Recover', and DAL is fully committed to the WEEE Directive. DAL is a member of Clarity Environmental, an Environmental Compliance Agency, which has been approved by the UK Environment Agency. Via this scheme, DAL is doing the utmost to keep the costs of recycling to a minimum so that the benefits are passed on to you, the client, and society as a whole. DAL registration number WEE/EA0290TY.



Whilst every effort is made to give up-to-date information, the manufacturer reserves the right to amend any specification herein detailed without prior notice. Descriptions contained within this publication shall not form part of any contract. Orders accepted for DAL products are subject to our standard condition of sale. When products are made specially to customers' requirements, we cannot make subsequent alteration or accept cancellation or return without making a charge.

It is essential that the correct LED/lamp type must be used. Incorrect LEDs/lamps may affect the operation of the luminaire and in some cases seriously overheat the luminaire. All fittings in this brochure are supplied with LEDs. Dimensions are shown in mm.

For full Terms and Conditions please contact us or visit our website www.dal-uk.com.

SMALL APERTURE

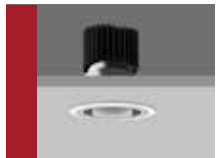

AMBIANCE L73
p11



AMBIANCE L73
DIRECTIONAL
p11



AMBIANCE L73
KICK WALLWASHER
p12



AMBIANCE L74
p12

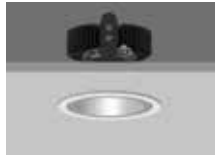

AMBIANCE X100
p13



AMBIANCE X100
DIRECTIONAL
p13



AMBIANCE X100
LENS WALLWASHER
p14



AMBIANCE L100
p14



AMBIANCE L100
DIRECTIONAL
p15



AMBIANCE L100
LENS WALLWASHER
p15



MINITRIM X86
p16



MINITRIM X86
DIRECTIONAL
p16



JAZZ X100
DIRECTIONAL
p17



JAZZ X110
DIRECTIONAL
p17



QUINTA C100
p18



QUINTA C100
DIRECTIONAL
p18



QUINTA C100
DOUBLE
p19



QUINTA C100 SQ
p20



QUINTA C100 SQ
DIRECTIONAL
p20



QUINTA C100 SQ
DOUBLE
p21



AMBIANCE SQ X70
p23



AMBIANCE SQ X100
p23



QUAD X86 / L86
SINGLE
p24



QUAD X86 / L86
DOUBLE
p24



QUAD 86 SINGLE
SHALLOW
p25



POPPY X100
p25

DEEP CONE



VP X73
p29



VP X73
KICK WALLWASHER
p29



VP X100
p30



VP X100
KICK WALLWASHER
p30



VP X100
DIRECTIONAL
p31



VP X143
p33



VP X143
KICK WALLWASHER
p33



VP X143
LENS WALLWASHER
p34

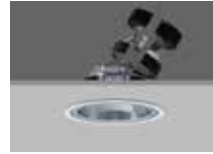

VP X143
DIRECTIONAL
p34



VP X143 CORNER
KICK WALLWASHER
p35



VP X143 DOUBLE
KICK WALLWASHER
p35



VP X161
p36



VP X161
KICK WALLWASHER
p36



VP X161
LENS WALLWASHER
p37



VP X161
DIRECTIONAL
p37

TRIMLESS



TRIMLESS
AMBIANCE X53 SQ
p41



TRIMLESS
AMBIANCE X80 SQ
p41



TRIMLESS
AMBIANCE X80
p42



TRIMLESS AMBIANCE
X80 LENS WALLWASH
p42



TRIMLESS AMBIANCE
X80 DIRECTIONAL
p43



TRIMLESSVP X82
p44



TRIMLESSVP X82
KICK WALLWASHER
p44



TRIMLESSVP X124
p45



TRIMLESSVP X124
KICK WALLWASHER
p45



TRIMLESSVP X124
CORNER WALL
WASHER
p46



TRIMLESSVP X124
DOUBLE WALL
WASHER
p46



TRIMLESSVP X124
LENS WALLWASHER
p47



TRIMLESSVP X124
DIRECTIONAL
p47



TRIMLESSVP X140
p48



TRIMLESSVP X140
KICK WALLWASHER
p48



TRIMLESSVP X140
LENS WALLWASHER
p49



TRIMLESSVP X140
DIRECTIONAL
p49

SHALLOW DEPTH



TEMPO X161
p52



TEMPO X161 80°
p53



TEMPO X161
LENS WALLWASHER
p54



AMPIA X161
p54



ICE X161
p55



SQUARE X161
p56



SQUARE X161
LENS WALLWASHER
p57



SQUARE X161
DIRECTIONAL
p57

SURFACE MOUNTED



CIVIC X65
p60



CIVIC X102
p60



CIVIC X102
DIRECTIONAL
p61



CIVIC X165
p61



CIVIC G210
p65



SURFACEVP X140
p62



SURFACEVP X140
KICK WALLWASHER
p62



SURFACEVP X140
DIRECTIONAL
p63



SURFACEVP X161
p63



SURFACEVP X161
KICK WALLWASHER
p65

OFFICE



ATELIER FRAME
SQUARE MICRO
p74



ATELIER FRAME
LINEAR MICRO
p80



ATELIER FRAME
SQUARE OPAL
p75



ATELIER FRAME
LINEAR OPAL
p80



ATELIER PLUS
SQUARE
p85



ATELIER PLUS
LINEAR
p87



ATELIER PANEL
SQUARE
p85

LINEAR SYSTEMS

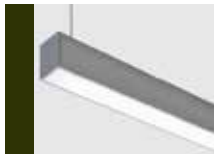

LIGHTLINE LED 60
SURFACE / PENDANT
p94



LIGHTLINE LED 60
DIRECT / INDIRECT
p95

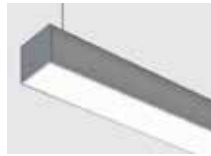

LIGHTLINE LED 88
SURFACE / PENDANT
p102



BORDO 150
p109-111



LIGHTLINE LED 60
RECESSED WITH TRIM
p96



LIGHTLINE LED 88
RECESSED WITH TRIM
p104



LIGHTLINE LED 60
TRIMLESS
p98



LIGHTLINE LED 88
TRIMLESS
p106



COVELINE LED
p114



GRAZER LED
p118



PROJECTOR LED
p118



TERRA LED 150
p122



WALLWASHER LED
p112

GALLERY SPOTLIGHTS & WASHLIGHTS



BALTIC X
p130-131



IKON WASHLIGHT
p132-133

EMERGENCY MODULES AND EXIT SIGNS



WAYLIGHT 3
p138



WAYLIGHT 3
ROUND SURFACE
p140



WAYLIGHT 3
SQUARE SURFACE
p141



LEDEX S
SURFACE
p142



LEDEX R
SURFACE
p143



LEDEX SP
SURFACE
p143



COMPONENTS
p144

CUSTOM PROJECTS



LINEAR
p148



PENDANT
p148



WASHLIGHT
p149



PICTURE LIGHT
p149



WALL AND CEILING
LIGHTS
p150



WALL MOUNTED
DIRECT / INDIRECT
p151

DESIGN, PLANNING & TECHNOLOGY



CONSERVATION
p145



DISPLAY LIGHTING &
VISUAL EFFECTS
p134



ENERGY USE
p145

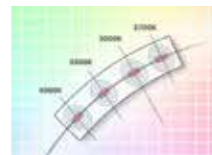

LED TECHNOLOGY
p152

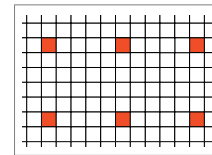

LIGHT PLANNING &
REGULATIONS
p69



THE LIT SCENE
p91

LIGHT ENGINES, DRIVERS & INDEX

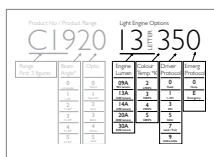

LIGHT ENGINES &
DRIVERS
p154

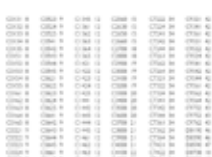

NAME & CATALOGUE
INDEX
p156



Al Jazeera Media Network
Architect: John McAslan + Partners
Lighting Consultant: GIA Equation



Many of London's structures: Tower Bridge, St Paul's Cathedral, the London Eye, vie for the title of top icon. Now it's The Shard that's drawing attention. Constructed over four years on a technically challenging site adjacent to London Bridge Station, amidst existing buildings, the 87-storey 1,004ft skyscraper forms the major part of The London Bridge Quarter. Opened to the public early in 2013, visitors can visit Level 69 and on a clear day view the panorama stretching for 40 miles.

As part of the project DAL supplied 3,000 luminaires of various types, including CIVIC X102 and AMBIANCE X100 LED downlighters for the shell and core, the perimeters and the viewing platform. Al Jazeera Media Network, the Qatar based news station, was reported to be the first commercial tenant within The Shard. Whilst the News Corp, publisher of The Times, The Sunday Times and The Sun, occupies the Shard's sister building, The Place, where the same DAL fixtures are used.

The Shard
Architect: Renzo Piano
Lighting Consultant: ARUP Lighting
Construction Management: MACE
Photographer: © Dennis Gilbert/VIEW



Hilton London Wembley Stadium
Architect: The Manser Practice
Main Contractor: John Sisk
Photograph: ©Hilton Hotels & Resorts

With its proximity to Wembley Arena and the National Stadium the hotel has become a social hub within the regeneration of Wembley Park. Whether nursing a glass of whisky or having a pre-match lunch in the stylish Icons Bar visitors can relax in the environs surrounded by the

iconic Wembley Arch and the Arena. The Arena, built originally as a swimming pool for the 1934 Empire Games, has one of the largest ever built reinforced concrete roof spans, and has an English Heritage Grade 2* listing.

SMALL APERTURE

DAL's Small Aperture range of downlighters can satisfy a broad spectrum of architectural, display and accent lighting requirements. Most products are constructed with a two part cone detail, allowing options of reflector size and finish. With choices of aperture size, beam angle and output they offer the designer the opportunity to create both decorative and functional environments to the highest quality.

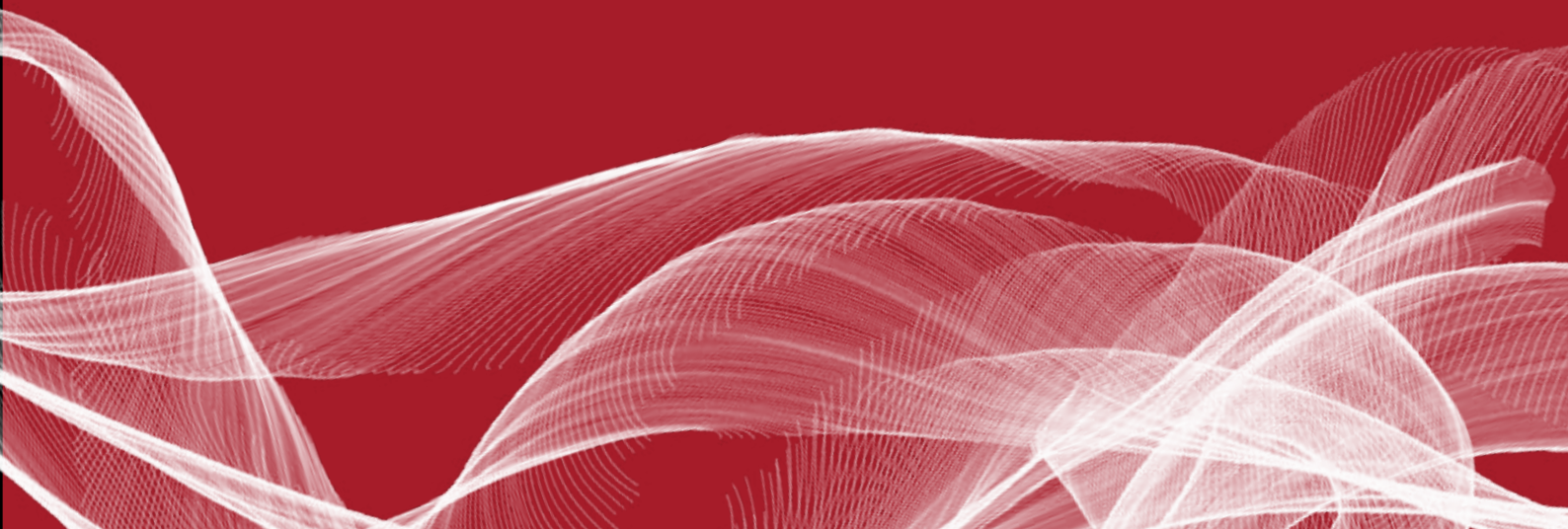

SMALL APERTURE KEY FEATURES

Service Life: 50,000 - L70-L80

Incorporating LED manufacturers such as Xicato and Lumileds

Future proofed Zhaga compatible LEDs

Colour Rendering:
 Xicato Ra >80 2 Step MacAdam as standard
 Ra >95 to special order
 COB Technology Ra > 80 as standard
 Ra >90 to special order

Colour Temperatures available:
 2700K, 3500, 3000K or 4000K

Standard luminous flux packages currently available: 1000 - 3000 lumens.
 For higher lumen output LEDs please contact us.

Passive cooling systems

All products are IP 20 minimum

Built to compliance EN 60598-1

Class III construction

Two piece reflector system

Diameters:
 73mm, 86mm, 100mm, 110mm

Squares:
 70mm, 74mm, 86mm, 100mm

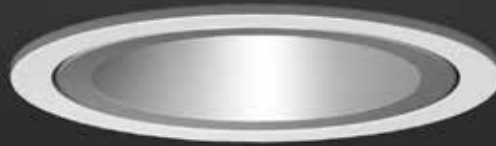
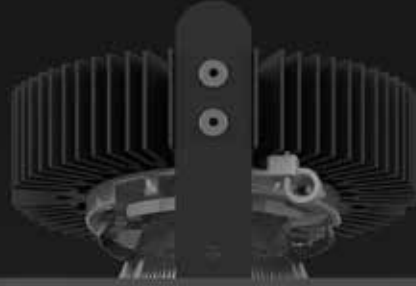

Beam angles:
 Spot, Medium, Flood. 20 - 60 degree

Lockable directional facility on some products

Dimming protocols:
 DALI, 1-10V, Lead/trailing edge

Emergency modes and conversions available

Reflector Finishes:
 Specular Silver, Satin Silver, Black, White and Gold

Mounting details:
 Recessed with standard finish trim RAL 9010.

Minitrim and Trimless are also available

To ensure downlighter heights and ceilings are compatible on-site recess depths should be checked.



Standard ceiling trim



Combined deep cone reflector and trim



Passive cooling systems are designed to suit lumen outputs

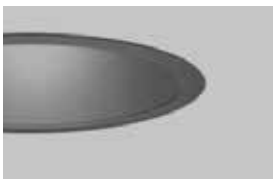

Mini trim



Combined reflector and trim

Circular Downlighters - Trim details



Combined reflector and trim



Reflector edge detail and trim

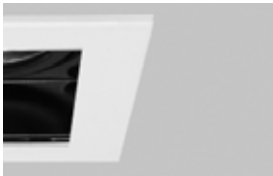

No reflector edge full trim

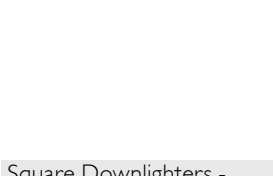

Square Downlighters - Trim details

Square Downlighters - Trim details

	AMBIANCE L73	AMBIANCE L74	AMBIANCE X100	AMBIANCE L100	MINITRIM X86	JAZZ X100	JAZZ X110	POPPY X100	QUINTA ROUND C100	QUINTA SQUARE C100	SQUARE AMBIANCE X100 / L100	QUAD X86 / L86
●	○	○	○	○	○	○	○	○	○	○	□	□

FIXED DOWNLIGHTER

DIRECTIONAL TILT

LENS WALLWASHER

KICK WALLWASHER

IP44

Up to 720lms

Up to 1000lms

Up to 1200lm

Up to 1300lms

Up to 2000lms

Up to 3000lms

AMBIANCE L73

SPECULAR SILVER, SPECTRO SILVER, SATIN SILVER, BLACK, WHITE, GOLD

AMBIANCE L73 FIXED Round recessed downlighter with standard white ceiling trim and a choice of deep cone reflector finish and beam distribution. Overall diameter 73mm, cut out 67mm diameter. COB LED Technology.



Beam	Specular Silver	Spectro Silver	Satin Silver	Black	White	Gold
------	-----------------	----------------	--------------	-------	-------	------

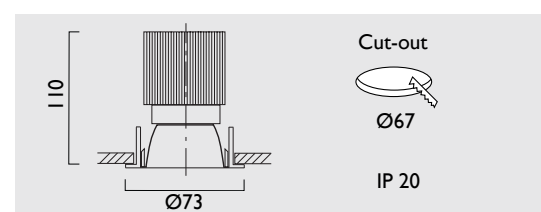

Light Fixture IP20 - Up to 1000lms

28°	C0131	C0138	C0132	C0133	C0134	C0135
45°	C0151	C0158	C0152	C0153	C0154	C0155
56°	C0161	C0168	C0162	C0163	C0164	C0165

To specify the Light Engine & Driver code please refer to pages 154-155.

AMBIANCE L73 DIRECTIONAL

SPECULAR SILVER, SPECTRO SILVER, SATIN SILVER, BLACK, WHITE, GOLD

AMBIANCE L73 DIRECTIONAL Round recessed downlighter with standard white ceiling trim and a choice of deep cone reflector finish and beam distribution. 0-25° tilt. Overall diameter 73mm, cut out 67mm diameter. COB LED Technology.



Beam	Specular Silver	Spectro Silver	Satin Silver	Black	White	Gold
------	-----------------	----------------	--------------	-------	-------	------

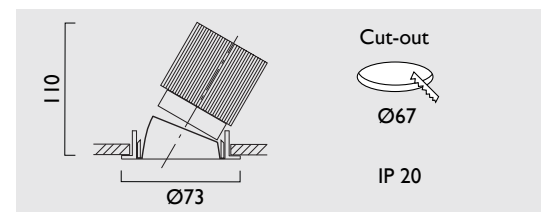

Light Fixture IP20 - Up to 1000 lms

28°	C0231	C0238	C0232	C0233	C0234	C0235
45°	C0251	C0258	C0252	C0253	C0254	C0255
56°	C0261	C0268	C0262	C0263	C0264	C0265

To specify the Light Engine & Driver code please refer to pages 154-155.

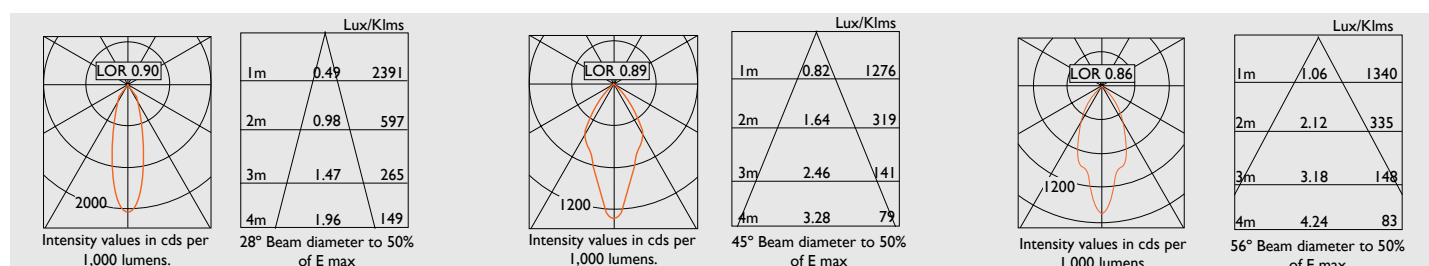

SMALL APERTURE

AMBIANCE L73 KICK WALLWASHER

SPECTRO SILVER

AMBIANCE L73 KICK WALLWASHER Round recessed wallwasher with white ceiling trim and low glare, deep cone, diffused spectro silver reflector and lens optic. Overall diameter 73mm, cut out 67mm diameter. COB LED Technology.

Product No

Light Fixture IP20 - Up to 1000lms
G4008

To specify the Light Engine & Driver code please refer to pages 154-155.

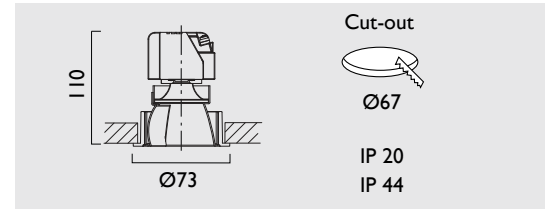

AMBIANCE L74

WHITE

AMBIANCE L74 FIXED Round recessed downlighter with a one-piece combined deep cone reflector and trim ceiling trim in white and a choice of beam distribution. Overall diameter 74mm, cut out 67mm diameter. COB LED Technology.

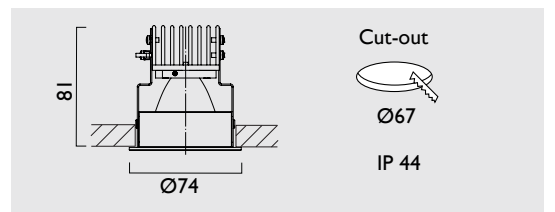

Beam White

Light Fixture IP44 - Up to 1000 lms

15°	F0114
24°	F0124
38°	F0144
60°	F0164

To specify the Light Engine & Driver code please refer to pages 154-155.

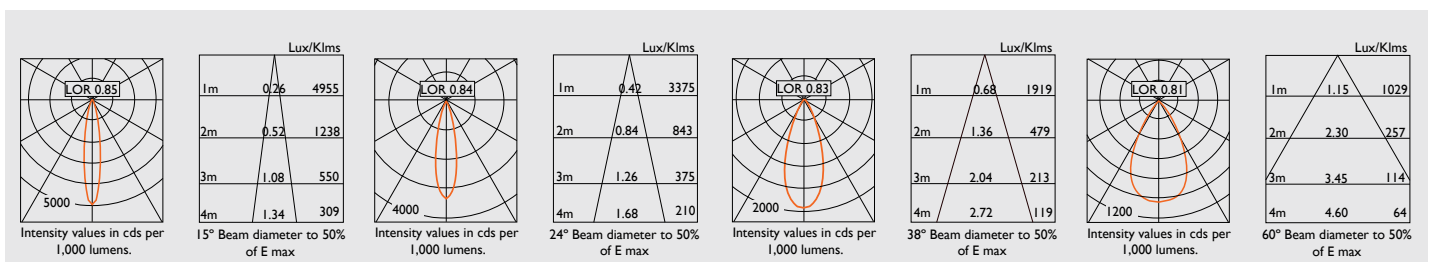

AMBIANCE X100

SPECULAR SILVER, SATIN SILVER, BLACK, WHITE, GOLD

AMBIANCE X100 FIXED Round recessed downlighter with standard white ceiling trim and a choice of deep cone reflector finish and beam distribution. Overall diameter 100mm, cut out 90mm diameter. Xicato LED.

Beam	Specular Silver	Satin Silver	Black	White	Gold
Light Fixture IP20 - Up to 2000lms (XTM)					
20°	C0321	C0322	C0323	C0324	C0325
40°	C0341	C0342	C0343	C0344	C0345
60°	C0361	C0362	C0363	C0364	C0365
Light Fixture IP44 - Up to 2000lms (XTM)					
20°	C0421	C0422	C0423	C0424	C0425
40°	C0441	C0442	C0443	C0444	C0445
60°	C0461	C0462	C0463	C0464	C0465

To specify the Light Engine & Driver code please refer to pages 154-155.

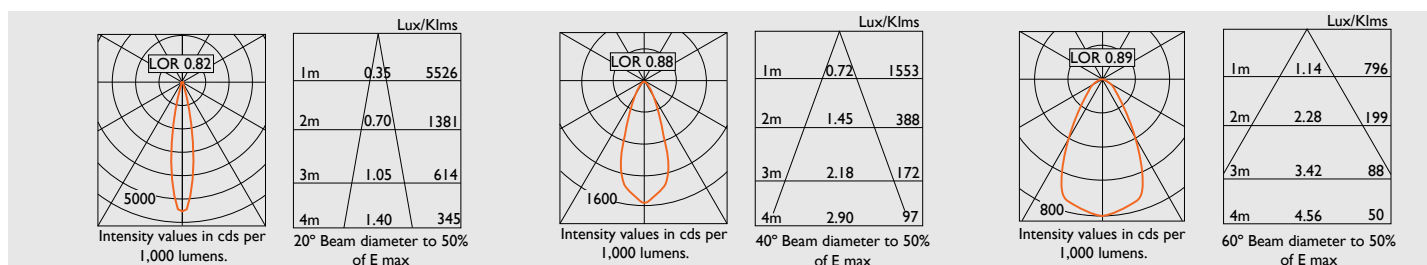
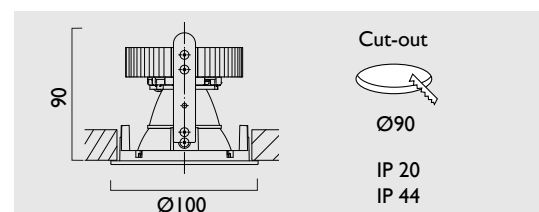
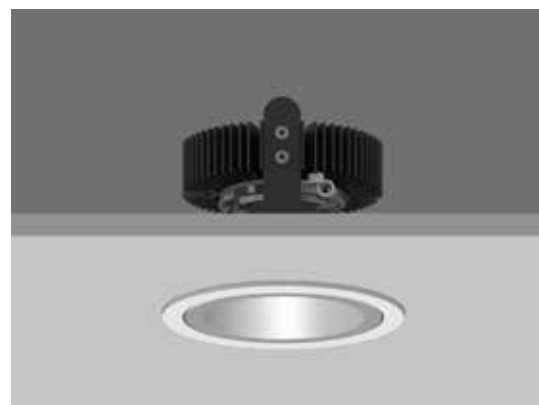

AMBIANCE X100 DIRECTIONAL

SPECULAR SILVER, SATIN SILVER, BLACK, WHITE, GOLD

AMBIANCE X100 DIRECTIONAL Round recessed downlighter with standard white ceiling trim and a choice of deep cone reflector finish and beam distribution. 0-30° lockable tilt. Overall diameter 100mm, cut out 90mm diameter. Xicato LED.

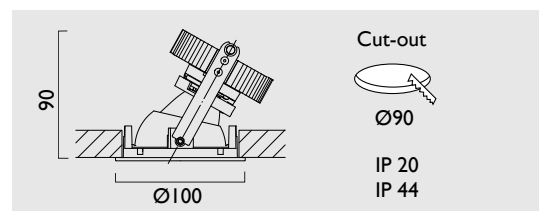
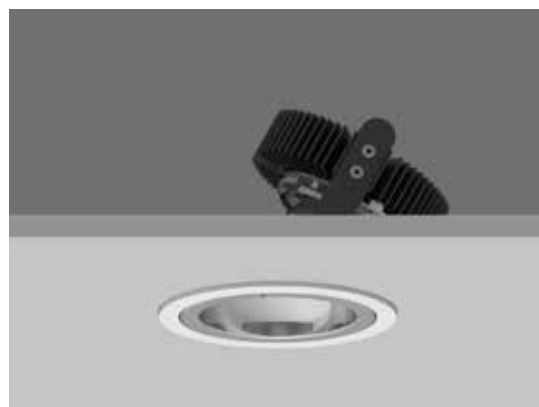

Beam	Specular Silver	Satin Silver	Black	White	Gold
Light Fixture IP20 - Up to 2000lms (XTM)					
20°	C0521	C0522	C0523	C0524	C0525
40°	C0541	C0542	C0543	C0544	C0545
60°	C0561	C0562	C0563	C0564	C0565
Light Fixture IP44 - Up to 2000lms (XTM)					
20°	C0621	C0622	C0623	C0624	C0625
40°	C0641	C0642	C0643	C0644	C0645
60°	C0661	C0662	C0663	C0664	C0665

To specify the Light Engine & Driver code please refer to pages 154-155.



AMBIANCE X100

LENS WALLWASHER

SPECULAR SILVER, SATIN SILVER, BLACK, WHITE, GOLD

AMBIANCE X100 LENS WALLWASHER Round recessed wallwasher with standard white ceiling trim and a choice of deep cone reflector finish and spread lens. Overall diameter 100mm, cut out 90mm diameter Xicato LED.



Product No	Reflector
Light Fixture IP20 - Up to 2000lms (XTM)	
C0701	Specular Silver
C0702	Satin Silver
C0703	Black
C0704	White
C0705	Gold

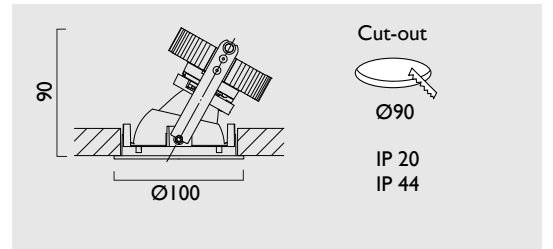

To specify the Light Engine & Driver code please refer to pages 154-155.

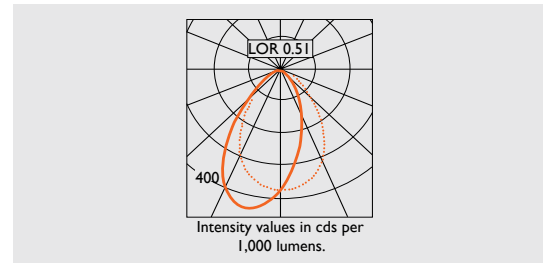

AMBIANCE L100

SPECULAR SILVER, SATIN SILVER, BLACK, WHITE, GOLD

AMBIANCE L100 FIXED Round recessed downlighter with standard white ceiling trim and a choice of deep cone reflector finish and beam distribution. Overall diameter 100mm, cut out 90mm diameter. COB LED Technology.



Beam	Specular Silver	Satin Silver	Black	White	Gold
Light Fixture IP20 - Up to 1200lms COB Technology.					
24°	C0931	C0932	C0933	C0934	C0935
38°	C0941	C0942	C0943	C0944	C0945
60°	C0961	C0962	C0963	C0964	C0965

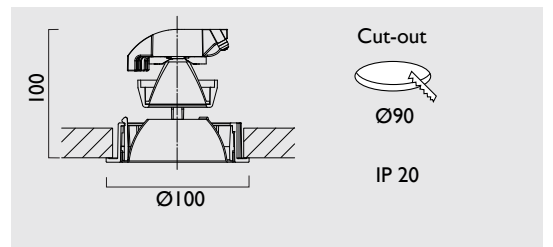

To specify the Light Engine & Driver code please refer to pages 154-155

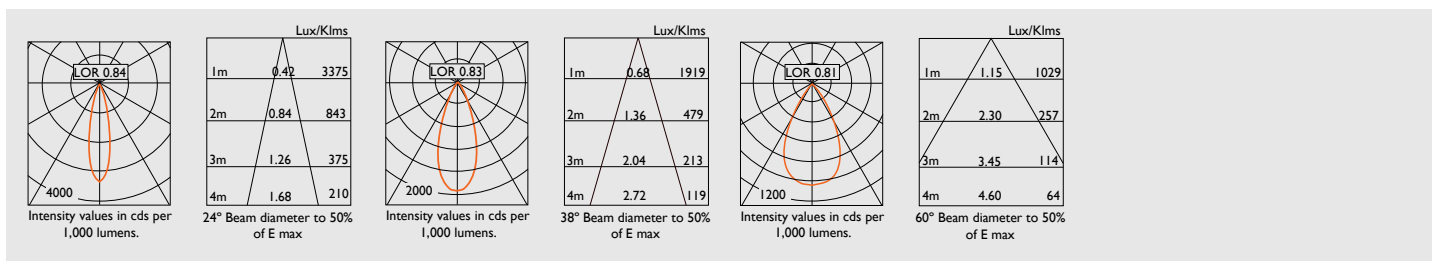

AMBIANCE LI00

DIRECTIONAL

SPECULAR SILVER, SATIN SILVER, BLACK, WHITE, GOLD

AMBIANCE LI00 DIRECTIONAL Round recessed downlighter with standard white ceiling trim and a choice of deep cone reflector finish and beam distribution. 0-30° tilt, 340° rotation.

Overall diameter 100mm, cut out 90mm. COB LED Technology.

Beam	Specular Silver	Satin Silver	Black	White	Gold
Light Fixture IP20 - Up to 1200lms COB LED Technology.					
24°	C1131	C1132	C1133	C1134	C1135
48°	C1151	C1152	C1153	C1154	C1155
60°	C1161	C1162	C1163	C1164	C1165

To specify the Light Engine & Driver code please refer to pages 154-155.

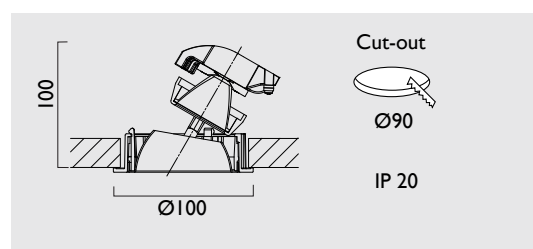

AMBIANCE LI00

LENS WALLWASHER

SPECULAR SILVER, SATIN SILVER, BLACK, WHITE, GOLD

AMBIANCE LI00 LENS WALLWASHER Round recessed wallwasher with standard white ceiling trim and a choice of deep cone reflector finish.

Overall diameter 100mm, cut out 90mm diameter. COB LED Technology.

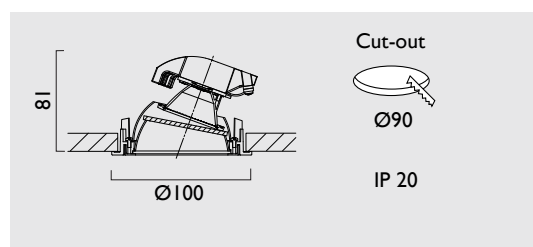

Product No	
Light Fixture IP20 - Up to 1200lms COB Technology.	
C1201	Specular Silver
C1202	Satin Silver
C1203	Black
C1204	White
C1205	Gold

To specify the Light Engine & Driver code please refer to pages 154-155.



MINITRIM X86

SPECULAR SILVER, SATIN SILVER, BLACK, WHITE, GOLD

MINITRIM X86 FIXED Round recessed downlighter with no separate ceiling trim and a choice of deep cone reflector finish and beam distribution.
Overall diameter 86mm, cut out 81.5mm diameter. Xicato LED.



Beam	Specular Silver	Satin Silver	Black	White	Gold
Light Fixture IP20 - Up to 2000 lms (XTM)					
20°	C1321	C1322	C1323	C1324	C1325
40°	C1341	C1342	C1343	C1344	C1345
60°	C1361	C1362	C1363	C1364	C1365
Light Fixture IP44 - Up to 2000 lms (XTM)					
20°	C1421	C1422	C1423	C1424	C1425
40°	C1441	C1442	C1443	C1444	C1445
60°	C1461	C1462	C1463	C1464	C1465

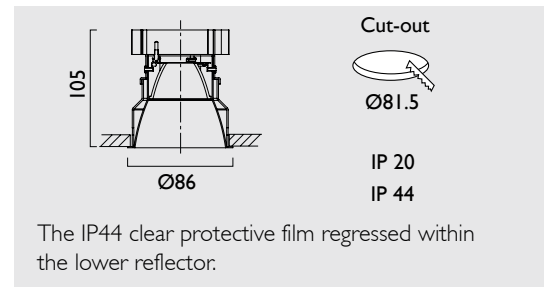

To specify the Light Engine & Driver code please refer to pages 154-155.

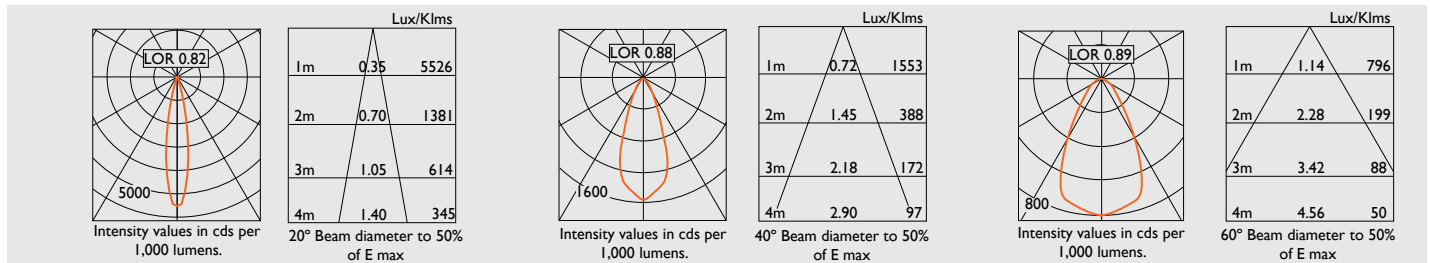

MINITRIM X86 DIRECTIONAL

SPECULAR SILVER, SATIN SILVER, BLACK, WHITE, GOLD

MINITRIM X86 DIRECTIONAL Round recessed downlighter with no separate ceiling trim and a choice of deep cone reflector finish and beam distribution. 0-25° tilt, 340° rotation.
Overall diameter 86mm, cut out 81.5mm diameter. Xicato LED.



Beam	Specular Silver	Satin Silver	Black	White	Gold
Light Fixture IP20 - Up to 2000 lms (XTM)					
20°	D6121	D6122	D6123	D6124	D6125
40°	D6141	D6142	D6143	D6144	D6145
60°	D6161	D6162	D6163	D6164	D6165
Light Fixture IP44 - Up to 2000 lms (XTM)					
20°	D6221	D6222	D6223	D6224	D6225
40°	D6241	D6242	D6243	D6244	D6245
60°	D6261	D6262	D6263	D6264	D6265

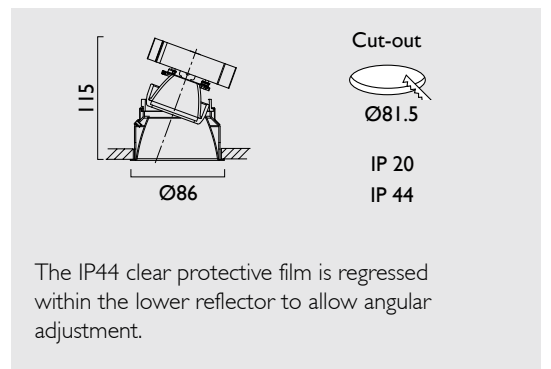

To specify the Light Engine & Driver code please refer to pages 154-155.



JAZZ XI00

DIRECTIONAL

WHITE

JAZZ XI00 DIRECTIONAL Round recessed pivot-style downlighter with black low-glare baffle, white housing and ceiling trim. 0-25° lockable tilt. Overall diameter 100mm, cut out 90mm diameter. Xicato LED. Overall height varies in relation to LED lumen output.

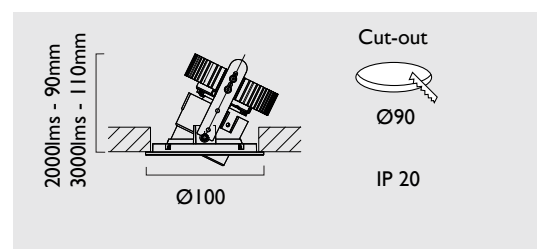
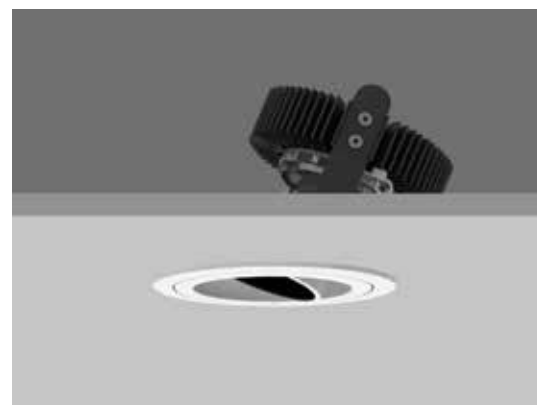

Product No Beam

Light Fixture IP20 - Up to 2000 lms (XTM)

C1520 20°

C1540 40°

C1560 60°

Light Fixture IP20 - Up to 3000 lms (XTM)

C1620 20°

C1640 40°

C1660 60°

To specify the Light Engine & Driver code please refer to pages 154-155.

JAZZ XI10

DIRECTIONAL

WHITE

JAZZ XI10 DIRECTIONAL Round recessed pivot-style downlighter with black low-glare baffle, white housing and ceiling trim. 0-25° lockable tilt, 340° rotation. Overall diameter 110mm, cut out 104mm diameter. Xicato LED. Overall height varies in relation to LED lumen output.

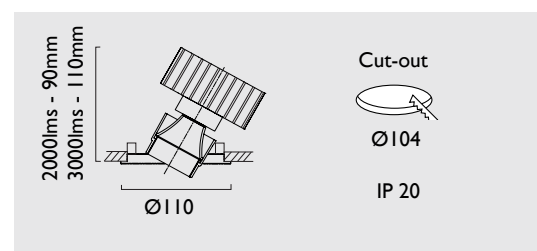

Product No Beam

Light Fixture IP20 - Up to 2000 lms (XTM)

C1720 20°

C1740 40°

C1760 60°

Light Fixture IP20 - Up to 3000 lms (XTM)

C1820 20°

C1840 40°

C1860 60°

To specify the Light Engine & Driver code please refer to pages 154-155.

SMALL APERTURE

QUINTA C100 ROUND DIRECTIONAL

WHITE

QUINTA C100 ROUND DIRECTIONAL Recessed downlighter with a one-piece combined reflector and ceiling trim in white and a choice of beam distribution. 0-28° tilt, 340° rotation.

Overall diameter 100mm, cut out 90mm diameter. COB LED Technology.



Beam	Product No
Light Fixture IP20 - Up to 1200 lms	
15°	G0120
24°	G0130
38°	G0140
60°	G0160
Light Fixture IP44 - Up to 1200 lms	
15°	G0220
24°	G0230
38°	G0240
60°	G0260

To specify the Light Engine & Driver code please refer to pages 154-155.

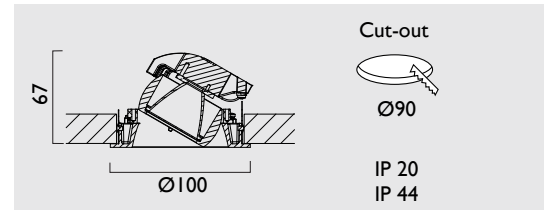

QUINTA C100 ROUND FIXED

WHITE

QUINTA C100 ROUND FIXED Recessed downlighter with a one-piece combined reflector and ceiling trim in white and a choice of beam distribution.

Overall diameter 100mm, cut out 90mm diameter diam. COB LED Technology.



Beam	Product No
Light Fixture IP20 - Up to 1200 lms	
15°	G1120
24°	G1130
38°	G1140
60°	G1160
Light Fixture IP44 - Up to 1200 lms	
15°	G1220
24°	G1230
38°	G1240
60°	G1260

To specify the Light Engine & Driver code please refer to pages 154-155.

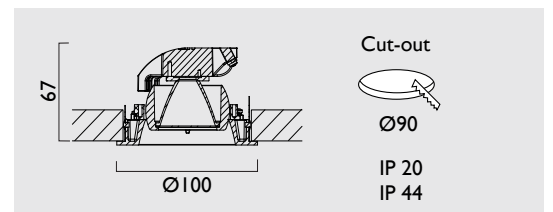

QUINTA C100 ROUND DOUBLE DIRECTIONAL

WHITE

QUINTA C100 OBROUND DOUBLE DIRECTIONAL Recessed downlighters with a one-piece combined reflector and ceiling trim in white and a choice of beam distribution. 0-28° tilt, 340° rotation.

Overall size 100mm x 186mm, cut out 90mm x 90mm. COB LED Technology.

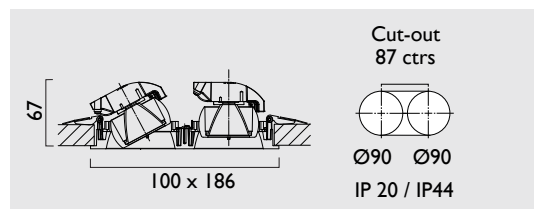
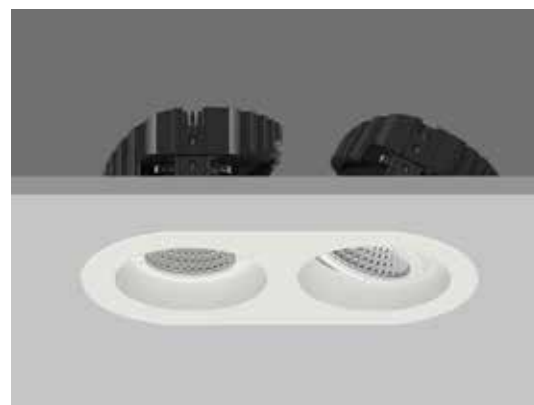

Beam Product No

Light Fixture IP20 - Up to 1200 lms

15° G0520

24° G0530

38° G0540

60° G0560

Light Fixture IP44 - Up to 1200 lms

15° G0620

24° G0630

38° G0640

60° G0660

To specify the Light Engine & Driver code please refer to pages 154-155.

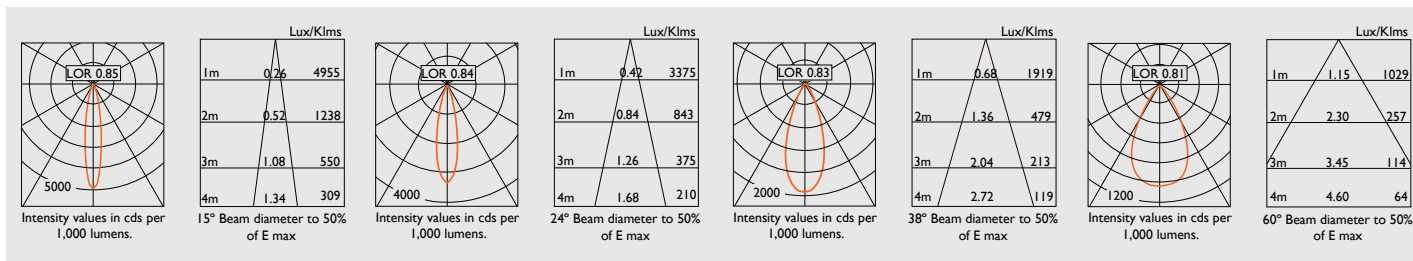

QUINTA Photometric data.

SMALL APERTURE

QUINTA C I 00 SQUARE DIRECTIONAL

WHITE

QUINTA C I 00 SQUARE DIRECTIONAL Recessed downlighter with a one-piece combined reflector and ceiling trim in white and a choice of beam distribution. 0-28° tilt, 340° rotation.

Overall size 100mm x 100mm, cut out 90mm diameter. COB LED Technology.

Beam	Product No
------	------------

Light Fixture IP20 - Up to 1200 lms

15° G0320

24° G0330

38° G0340

60° G0360

Light Fixture IP44 - Up to 1200 lms

15° G0420

24° G0430

38° G0440

60° G0460

To specify the Light Engine & Driver code please refer to pages 154-155.

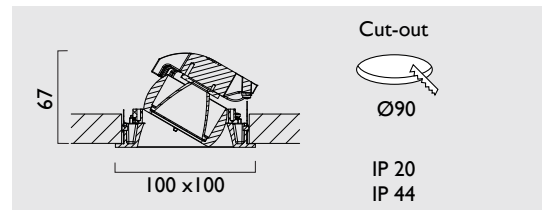

QUINTA C I 00 SQUARE FIXED

WHITE

QUINTA C I 00 SQUARE FIXED Recessed downlighter with a one-piece combined reflector and ceiling trim in white and a choice of beam distribution.

Overall size 100mm x 100mm, cut out 90mm diameter. COB LED Technology.

Beam	Product No
------	------------

Light Fixture IP20 - Up to 1200 lms

15° G1320

24° G1330

38° G1340

60° G1360

Light Fixture IP44 - Up to 1200 lms

15° G1420

24° G1430

38° G1440

60° G1460

To specify the Light Engine & Driver code please refer to pages 154-155.

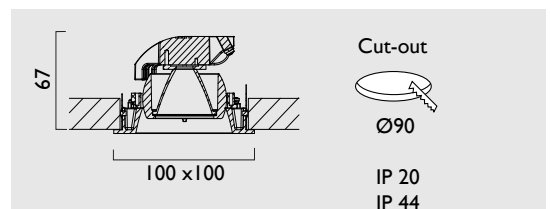

QUINTA C100 SQUARE DOUBLE DIRECTIONAL

WHITE

QUINTA C100 OBLONG DOUBLE DIRECTIONAL recessed downlighters with a one-piece combined reflector and ceiling trim in white and a choice of beam distribution. 0-28° tilt, 340° rotation.

Overall size 100mm x 186mm, cut out 90mm x 90mm. COB LED Technology.

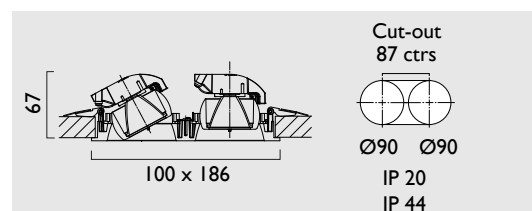
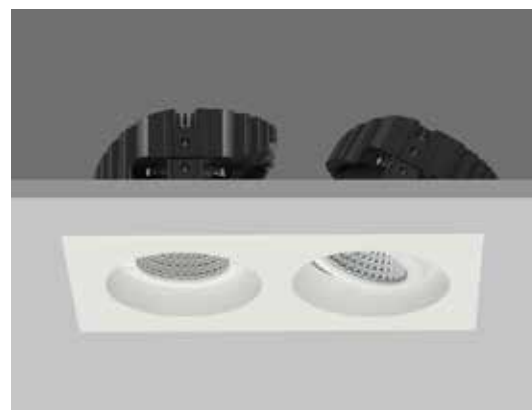

Beam Product No

Light Fixture IP20 - Up to 1200 lms

- 15° G0720
- 24° G0730
- 38° G0740
- 60° G0760

Light Fixture IP44 - Up to 1200 lms

- 15° G0820
- 24° G0830
- 38° G0840
- 60° G0860

To specify the Light Engine & Driver code please refer to pages 154-155.

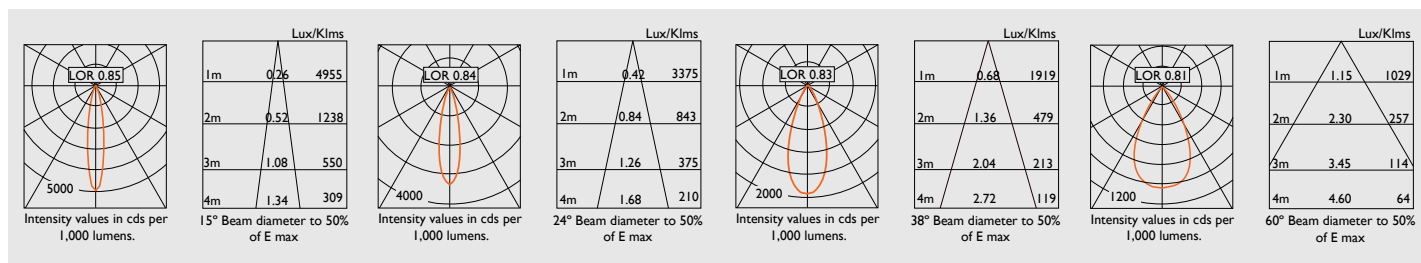

QUINTA Photometric data.



Pan Peninsula, Canary Wharf
Lighting Consultant: Maurice Brill Lighting Design
Architect: Skidmore, Owings Merrill, London
Interior Design: KCA International
Photographer: Tom Brill

Pan Peninsula Square is a distinctive residential development in the heart of London's docklands. The Six Senses Spa is located within the two apartment blocks, and overlooks the water of West India Quay and the glittering towers of Canary Wharf. Included in the lighting package were AMBIANCE IP44 downlighters.

AMBIANCE X70 SQUARE

BLACK, WHITE

AMBIANCE X70 SQUARE FIXED Recessed downlighter with white ceiling trim and a choice of deep baffle finish, lens optic and beam distribution.
Overall size 70mm x 70mm, cut out 68mm x 68mm. Xicato LED.

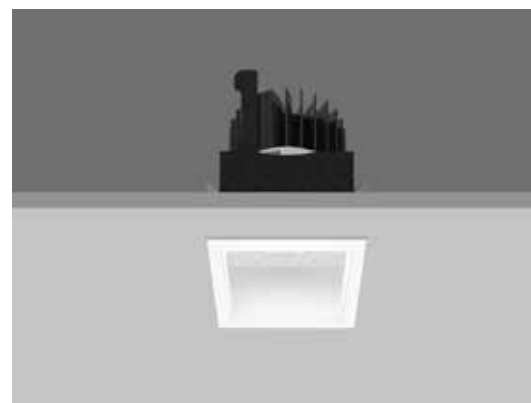

Beam	Black	White
Light Fixture IP20 - Up to 720 lms (XTM)		
30°	F1533	F1534
40°	F1543	F1544

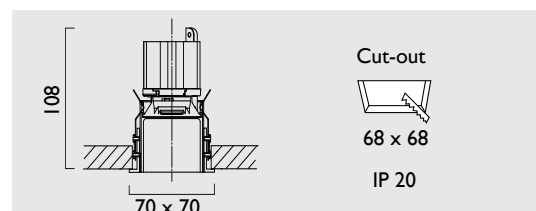

To specify the Light Engine & Driver code please refer to pages 154-155.

AMBIANCE X100 SQUARE

BLACK, WHITE

AMBIANCE X100 SQUARE FIXED Recessed downlighter with white ceiling trim and a choice of deep baffle finish and beam distribution.
Overall size 100mm x 100mm, cut out 95mm x 95mm. Xicato LED.



Beam	Black	White
Light Fixture IP20 - Up to 2000lms (XTM)		
40°	F0543	F0544
60°	F0563	F0564

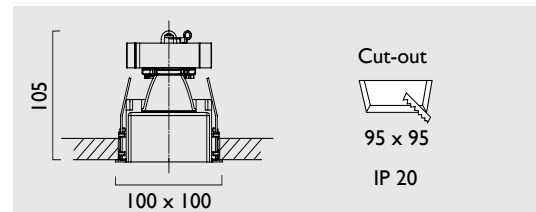

To specify the Light Engine & Driver code please refer to pages 154-155.

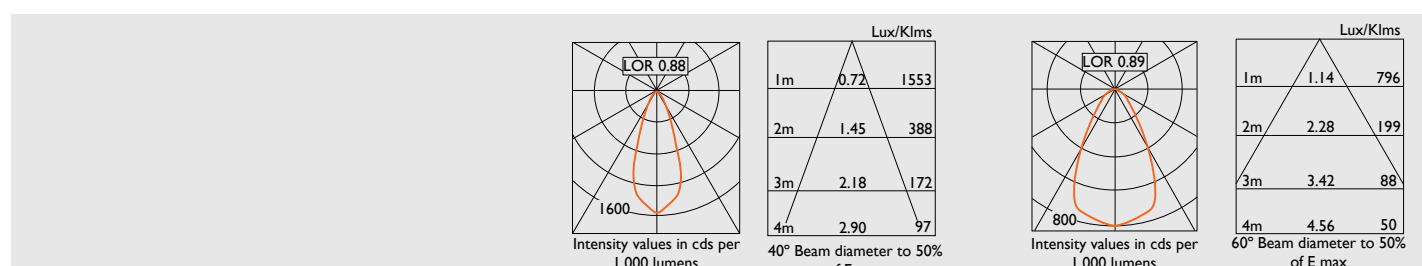

QUAD X86

QUAD L86

QUAD 86 DIRECTIONAL SQUARE Recessed downlighter with a choice of ceiling trim and black interior finish and beam distribution. 0-30° tilt, 340° rotation.

Overall dimension 86mm x 86mm, cut out 77mm x 77mm.

Xicato LED or COB LED Technology.

QUAD X86 - Xicato XTM - Up to 1300 lms

Ceiling trim finish	20°	40°	60°		Dim A (mm)
White	C1920	C1940	C1960	IP20	125mm
Black	D9520	D9540	D9560	IP20	125mm
White	C2020	C2040	C2060	IP44	125mm
Black	D9620	D9640	D9660	IP44	125mm

QUAD L86 - LED COB Technology - Up to 1200 lms

Ceiling trim finish	28°	45°	56°		Dim A (mm)
White	C2330	C2350	C2360	IP20	100mm
White	C2430	C2450	C2460	IP44	100mm

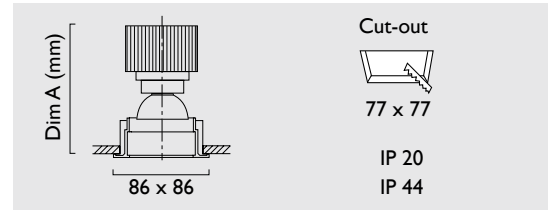

To specify the Xicato Light Engine & Driver code please refer to pages 154-155.

QUAD X86

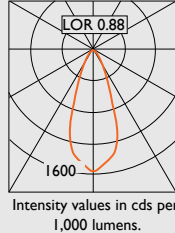

	Lux/Klms	
1m	0.72	1553
2m	1.45	388
3m	2.18	172
4m	2.90	97

40° Beam diameter to 50% of E max

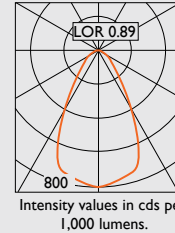

	Lux/Klms	
1m	1.14	796
2m	2.28	199
3m	3.42	88
4m	4.56	50

60° Beam diameter to 50% of E max

QUAD X86 DOUBLE

QUAD L86 DOUBLE

QUAD 86 DOUBLE DIRECTIONAL OBLONG Recessed downlighter with a choice of ceiling trim and black interior finish and beam distribution. 0-30° tilt, 340° rotation.

Overall dimension 160mm x 86mm, cut out 151mm x 77mm.

Xicato LED or COB LED Technology.

QUAD X86 - Xicato XTM - Up to 2 x 1300 lms

Ceiling trim finish	20°	40°	60°		Dim A (mm)
White	C2120	C2140	C2160	IP20	125mm
Black	D9720	D9740	D9760	IP20	125mm
White	C2220	C2240	C2260	IP44	125mm
Black	D9820	D9840	D9860	IP44	125mm

QUAD L86 - LED COB Technology - Up to 2 x 1200 lms

Ceiling trim finish	28°	45°	56°		Dim A (mm)
White	C2530	C2550	C2560	IP20	100mm
White	C2630	C2650	C2660	IP44	100mm

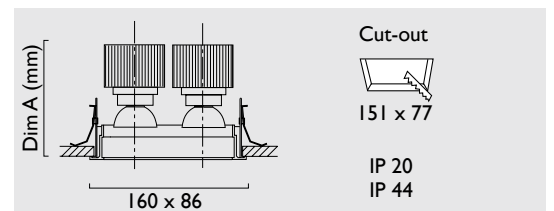

To specify the Light Engine & Driver code please refer to pages 154-155.

QUAD L86

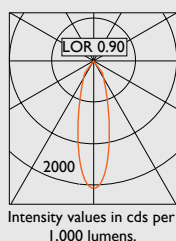

	Lux/Klms	
1m	0.49	2391
2m	0.98	597
3m	1.47	265
4m	1.96	149

28° Beam diameter to 50% of E max

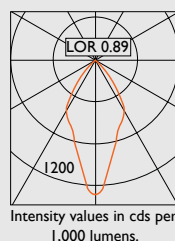

	Lux/Klms	
1m	0.82	1276
2m	1.64	319
3m	2.46	141
4m	3.28	79

45° Beam diameter to 50% of E max

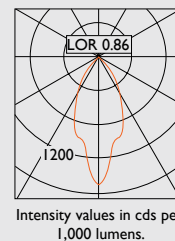

	Lux/Klms	
1m	1.06	1340
2m	2.12	335
3m	3.18	148
4m	4.24	83

56° Beam diameter to 50% of E max

QUAD L86 SHALLOW

QUAD L86 SHALLOW FIXED SQUARE Recessed downlighter with white ceiling trim and black interior.

Overall dimension 86mm x 86mm, cut out 77mm x 77mm.

COB LED Technology.



Product No	Beam Angle	Luminous Flux
------------	------------	---------------

Light Fixture IP20 - Up to 800 lms		
------------------------------------	--	--

F3740	60°	
-------	-----	--

Light Fixture IP44 - Up to 800 lms		
------------------------------------	--	--

F3840	60°	
-------	-----	--

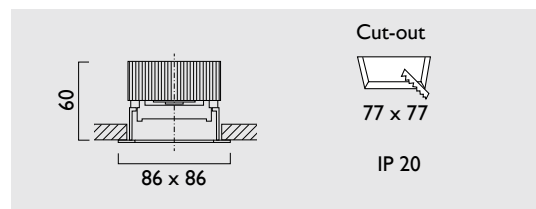

To specify the Xicato Light Engine & Driver code please refer to pages 154-155.

POPPY X100

POPPY X100 FIXED Round semi recessed downlighter with white ceiling trim and white satin opal glass shade.

Overall diameter 100mm, cut out 90mm. Xicato LED.



Product No	Beam Angle	Luminous Flux
------------	------------	---------------

Light Fixture IP20 - Up to 2000lms		
------------------------------------	--	--

G5040	40°	
-------	-----	--

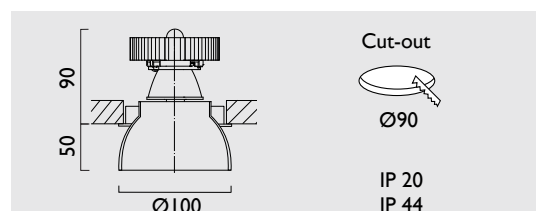

To specify the Xicato Light Engine & Driver code please refer to pages 154-155.



Niketown, Oxford Street, London
Lighting Consultant: NULTY +
Photographer: NULTY +

The Niketown in London's prestigious West End is a store with buzz. The state of the art interior with glass walls and black ceilings belie the classical style architecture of the building's exterior. Civic X102 is an effective lighting tool where recessing a small downlighter isn't possible. This was the case when lighting the NikeiDStudio, a space lined with desirable, jewel like shoes and Damien Hirst inspired display cabinets. DAL CIVIC X102s are installed in a trough edging the glass walled merchandise area, spreading light deep into the space. Against the black interior behind the glass box glows. The result is dramatic.

DEEP CONE

Visual Performance and Visual Comfort are key to the design of DAL Deep Cone downlighters. Designed for optimum glare control, VP luminaires ensure visual comfort together with high efficiency. The reflectors are finished in Spectro-Silver aluminium, a low brightness, highly reflective material, maximising LED performance.

With a choice of light distributions the VPX73, VPXI00, VPXI43 and VP XI61 recessed, ceiling trim luminaires offer the solution to many architectural and interior design projects.

DEEP CONE KEY FEATURES

Service Life: 50,000 - L70-L80

Incorporating LED manufacturers such as Xicato and Lumileds

Future proofed Zhaga compatible LEDs

Colour Rendering:
Xicato remote phosphor Ra >80
2 Step MacAdam as standard
Ra >95 to special order
Ra > 80 and Ra >90 COB Technology available

Colour Temperatures available:
2700K, 3500, 3000K or 4000K

Standard luminous flux packages currently available: 2000 - 4000 lumens.
For higher lumen output LEDs please contact us.

Passive cooling systems

All products IP 20 minimum

Built to compliance EN 60598-1

Class III construction

Two piece reflector system



Diameters:
73mm, 100mm, 143mm, 161mm,
Kick and lens wallwasher reflectors

Lockable directional facility on some products

Dimming protocols:
DALI, 1-10V, Lead/trailing edge

Emergency modes and conversions available

Reflector Finish:
Spectro Silver - a low glare, highly reflectivity, diffused material, offering high performance with visual comfort

Mounting details:
Recessed with standard finish trim RAL 9010

Trimless, plaster-in designs are also available. See page 42.

To ensure downlighter heights and ceilings are compatible on-site recess depths should be checked.



The thermal construction of VP downlighters include a thermal stop detail, ensuring the product is not compromised by restricted air flow around the LED.



VP Recessing fixing brackets are simple, with no tools needed when installing the downlighters.



VP Kick-reflector wallwasher detail.

VP X73
VP X100
VP X143
VP X161

	VP X73	VP X100	VP X143	VP X161
FIXED DOWNLIGHTER	●	●	●	●
KICK WALLWASHER	●	●	●	●
KICK DOUBLE WALLWASHER			●	●
KICK CORNER WALLWASHER			●	●
LENS WALLWASHER			●	●
DIRECTIONAL TILT		●	●	●
IP44	●	●	●	●
Up to 965 lms	●			
Up to 2000 lms		●	●	●
Up to 3000 lms			●	●
Up to 4000 lms				●

VP X73

SPECTRO SILVER

VP X73 FIXED Round recessed downlighter with white ceiling trim and low glare, deep cone diffused spectro silver reflector and lens optic.

Overall diameter 73mm, cut out 65mm diameter. Xicato LED.

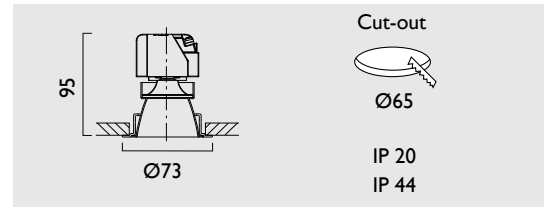

Product No

Light Fixture IP20 - Up to 965 lms (XTM)

D0708

Light Fixture IP44 - Up to 965 lms (XTM)

D0808

To specify the Light Engine & Driver code please refer to pages 154-155.

VP X73 KICK WALLWASHER

SPECTRO SILVER

VP X73 KICK WALLWASHER Round recessed wallwasher with white ceiling trim and low glare, deep cone, diffused spectro silver reflector and lens optic.

Overall diameter 73mm, cut out 65mm diameter. Xicato LED.

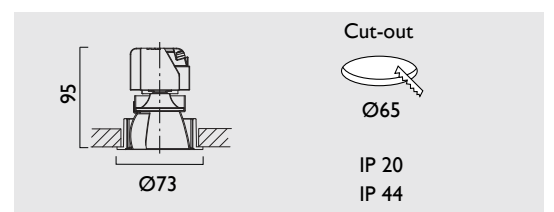

Product No

Light Fixture IP20 - Up to 965 lms (XTM)

F3008

To specify the Light Engine & Driver code please refer to pages 154-155.

DEEP CONE

VP X100

SPECTRO SILVER

VP X100 FIXED Round recessed downlighter with white ceiling trim and low glare, deep cone, diffused spectro silver reflector and lens optic.
Overall diameter 100mm, cut out 90mm diameter. Xicato LED.

Product No	Reflector
Light Fixture IP20 - Up to 2000 lms (XTM) C2708	Spectro Silver
Light Fixture IP44 - Up to 2000 lms (XTM) C2808	Spectro Silver

To specify the Light Engine & Driver code please refer to pages 154-155.

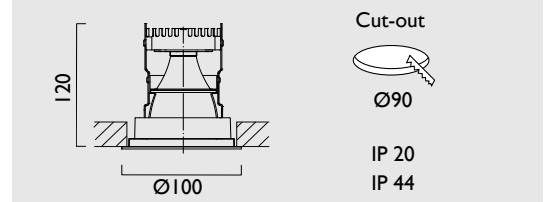

VP X100 KICK WALLWASHER

SPECTRO SILVER

VP X100 KICK WALLWASHER FIXED Round recessed wallwasher with white ceiling trim and low glare, deep cone, diffused spectro silver reflector and lens optic.
Overall diameter 100mm, cut out 90mm diameter. Xicato LED.

Product No	Reflector
Light Fixture IP20 - Up to 2000 lms (XTM) F2208	Spectro Silver

To specify the Light Engine & Driver code please refer to pages 154-155.

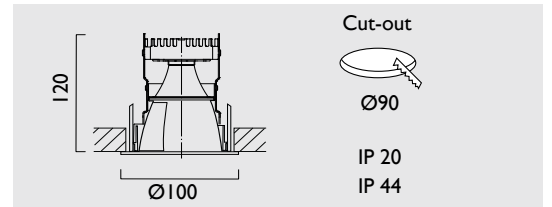
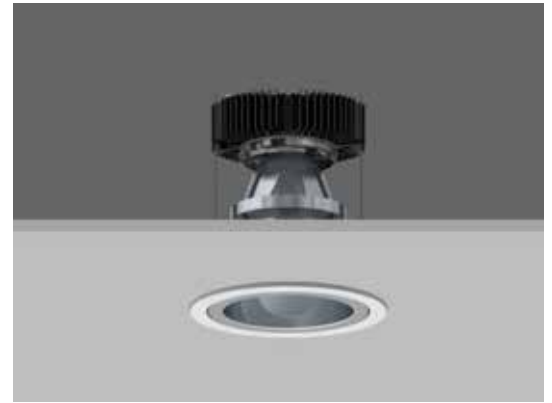

VP X100 DIRECTIONAL

SPECTRO SILVER

VP X100 DIRECTIONAL Round recessed with white ceiling trim and low glare, deep cone, diffused spectro silver reflector and lens optic. 0-25° tilt, 340° rotation.
Overall diameter 100mm, cut out 90mm diameter: Xicato LED.

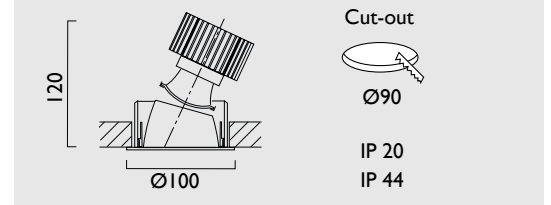

Product No	Reflector
Light Fixture IP20 - Up to 2000 lms (XTM) F2008	Spectro Silver
Light Fixture IP44 - Up to 2000 lms (XTM) F2108	Spectro Silver

To specify the Light Engine & Driver code please refer to pages 154-155.



Amazon 60 London, Holborn Viaduct
Consultant: Grontmij
Architect: KPF
Photographer: Edmund Sumner/VIEW

The recently completed building appears to nestle in the crook of Holborn Viaduct and Farringdon Street where one crosses over the other. In fact the building fills a full block of approximately 29,000 m². The façade is striking, a dynamic array of fins and shelves acting as shading over the curtain wall glazing with its unusual curved frontage. Built as a speculative development the multi-award winning building was leased as a whole by Amazon. DAL supplied AMBIANCE X100 downlighters, used throughout. The new building achieved a BREEAM 'Excellent' rating in recognition of its energy efficiency.

VP XI43

SPECTRO SILVER

VP XI43 FIXED Round recessed downlighter with white ceiling trim and low glare, deep cone, diffused spectro silver reflector and lens optic.
 Overall diameter 143mm, cut out 131mm diameter. Xicato LED.
 Overall height varies in relation to LED lumen output.



Product No	Luminous Flux (XTM)	Reflector	IP
C2908	Up to 2000 lms	Spectro Silver	IP20
C3008	Up to 2000 lms	Spectro Silver	IP44
F4608	Up to 3000 lms	Spectro Silver	IP20
F4708	Up to 3000 lms	Spectro Silver	IP44

To specify the Light Engine & Driver code please refer to pages 154-155.

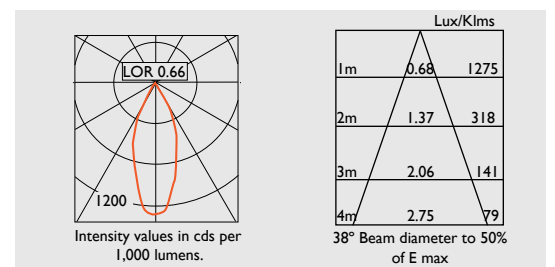
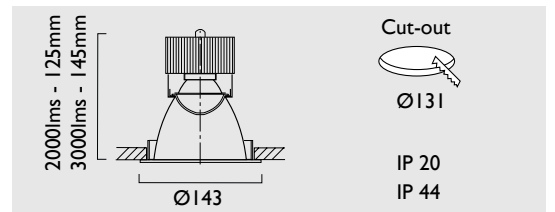

VP XI43 KICK WALLWASHER

SPECTRO SILVER

VP XI43 KICK WALLWASHER Round recessed wallwasher with white ceiling trim and low glare, deep cone, diffused spectro silver reflector and lens optic.
 Overall diameter 143mm, cut out 131mm diameter. Xicato LED.
 Overall height varies in relation to LED lumen output.



Product No	Luminous Flux (XTM)	Reflector	IP
C3108	Up to 2000 lms	Spectro Silver	IP20
C3208	Up to 2000 lms	Spectro Silver	IP44
F4808	Up to 3000 lms	Spectro Silver	IP20
F4908	Up to 3000 lms	Spectro Silver	IP44

To specify the Light Engine & Driver code please refer to pages 154-155.

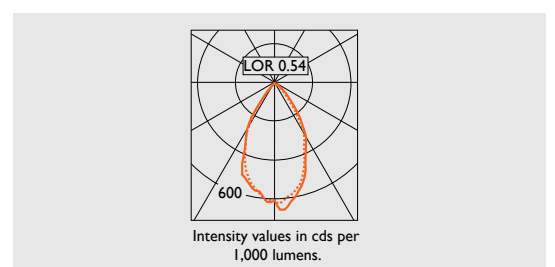
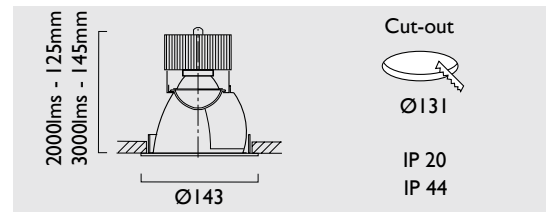

VP XI43 LENS WALLWASHER

SPECTRO SILVER

VP XI43 LENS WALLWASHER Round recessed wallwasher with white ceiling trim and low glare, deep cone, diffused spectro silver reflector and lens optic.
Overall diameter 143mm, cut out 131mm diameter. Xicato LED.
Overall height varies in relation to LED lumen output.

Product No	Luminous Flux (XTM)	Reflector	IP
C3308	Up to 2000 lms	Spectro Silver	IP20
C3408	Up to 2000 lms	Spectro Silver	IP44
F5008	Up to 3000 lms	Spectro Silver	IP20
F5108	Up to 3000 lms	Spectro Silver	IP44

To specify the Light Engine & Driver code please refer to pages 154-155.

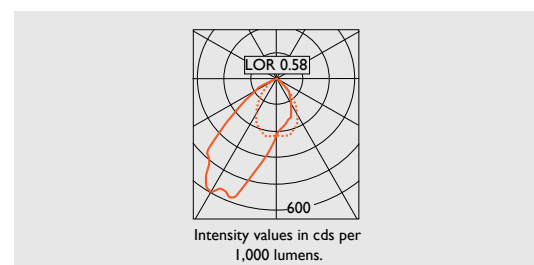
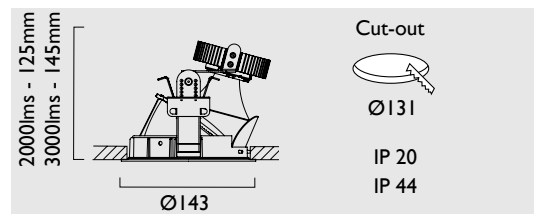

VP XI43 DIRECTIONAL

SPECTRO SILVER

VP XI43 DIRECTIONAL Round recessed downlighter with white ceiling trim and low glare, deep cone, diffused spectro silver reflector and lens optic. 0-28° lockable tilt, 340° rotation.
Overall diameter 143mm, cut out 131mm diameter. Xicato LED.
Overall height varies in relation to LED lumen output.

Product No	Luminous Flux (XTM)	Reflector	IP
C3508	Up to 2000 lms	Spectro Silver	IP20
C3608	Up to 2000 lms	Spectro Silver	IP44
F5208	Up to 3000 lms	Spectro Silver	IP20
F5308	Up to 3000 lms	Spectro Silver	IP44

To specify the Light Engine & Driver code please refer to pages 154-155.

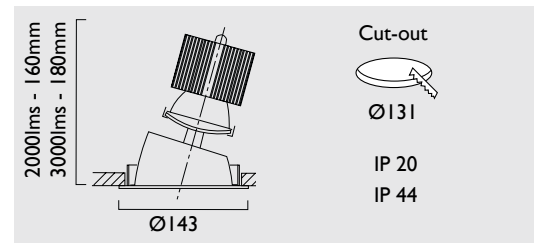
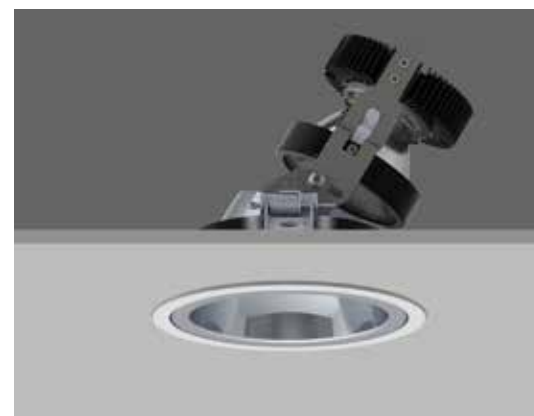

VP X143 CORNER KICK WALLWASHER

SPECTRO SILVER

VP X143 CORNER KICK WALLWASHER Round recessed wallwasher with white ceiling trim and low glare, deep cone, diffused spectro silver reflector and lens optic.
Overall diameter 143mm, cut out 131mm diameter. Xicato LED.
Overall height varies in relation to LED lumen output.

Product No	Luminous Flux (XTM)	Reflector	IP
C3708	Up to 2000 lms	Spectro Silver	IP20
C3808	Up to 2000 lms	Spectro Silver	IP44
F5408	Up to 3000 lms	Spectro Silver	IP20
F5508	Up to 3000 lms	Spectro Silver	IP44

To specify the Light Engine & Driver code please refer to pages 154-155.

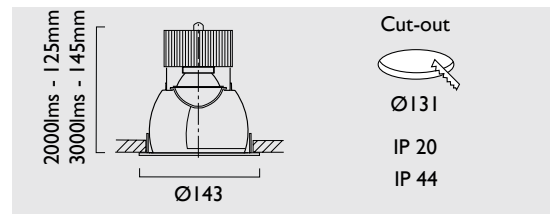

VP X143 DOUBLE KICK WALLWASHER

SPECTRO SILVER

VP X143 DOUBLE KICK WALLWASHER Round recessed wallwasher with white ceiling trim and low glare, deep cone, diffused spectro silver reflector and lens optic.
Overall diameter 143mm, cut out 131mm diameter. Xicato LED.
Overall height varies in relation to LED lumen output.

Product No	Luminous Flux (XTM)	Reflector	IP
C3908	Up to 2000 lms	Spectro Silver	IP20
C4008	Up to 2000 lms	Spectro Silver	IP44
F5608	Up to 3000 lms	Spectro Silver	IP20
F5708	Up to 3000 lms	Spectro Silver	IP44

To specify the Light Engine & Driver code please refer to pages 154-155.

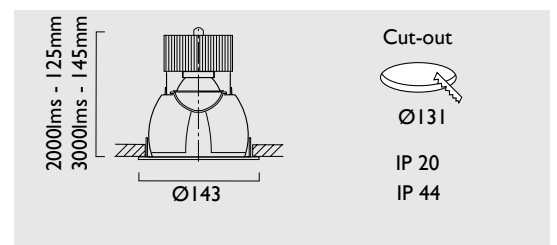

VP X161

SPECTRO SILVER

VP X161 FIXED Round recessed downlighter with white ceiling trim and low glare, deep cone, diffused spectro silver reflector and lens optic.
 Overall diameter 161mm, cut out 147mm diameter. Xicato LED.
 Overall height varies in relation to LED lumen output.

Product No	Luminous Flux (XTM)	Reflector	IP
C4108	Up to 2000 lms	Spectro Silver	IP20
C4208	Up to 2000 lms	Spectro Silver	IP44
F5808	Up to 4000 lms	Spectro Silver	IP20
F5908	Up to 4000 lms	Spectro Silver	IP44

To specify the Light Engine & Driver code please refer to pages 154-155.

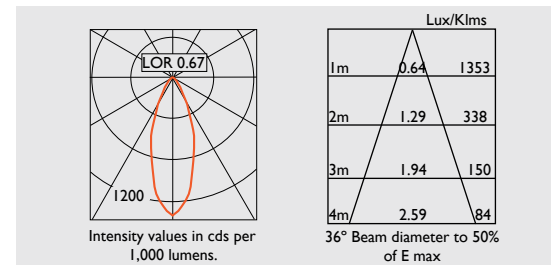
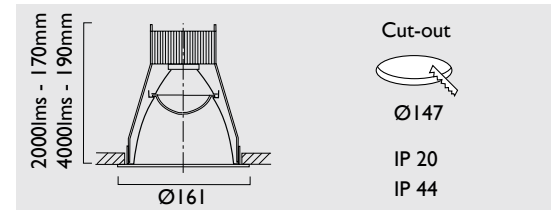
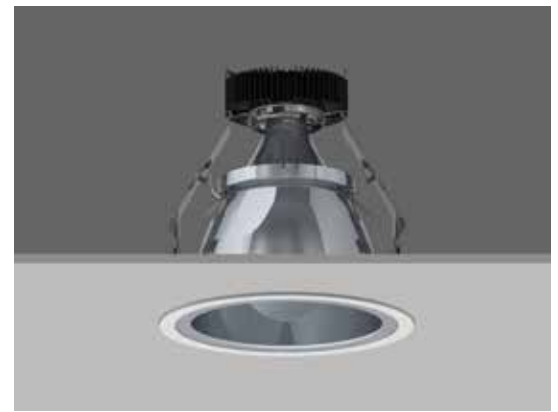

VP X161 KICK WALLWASHER

SPECTRO SILVER

VP X161 KICK WALLWASHER FIXED Round recessed wallwasher with white ceiling trim and low glare, deep cone, diffused spectro silver reflector and lens optic.
 Overall diameter 161mm, cut out 147mm diameter. Xicato LED.
 Overall height varies in relation to LED lumen output.

Product No	Luminous Flux (XTM)	Reflector	IP
C4308	Up to 2000 lms	Spectro Silver	IP20
C4408	Up to 2000 lms	Spectro Silver	IP44
F6008	Up to 4000 lms	Spectro Silver	IP20
F6108	Up to 4000 lms	Spectro Silver	IP44

To specify the Light Engine & Driver code please refer to pages 154-155.

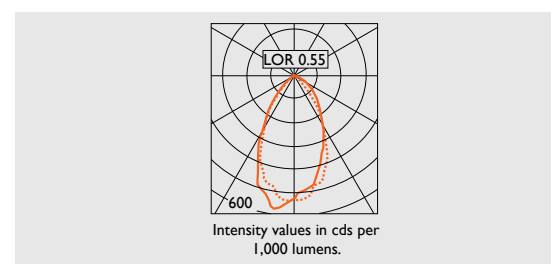
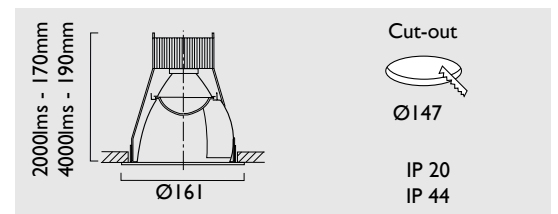

VP X161

LENS WALLWASHER

SPECTRO SILVER

VP X161 LENS WALLWASHER Round recessed wallwasher with white ceiling trim and low glare, deep cone, diffused spectro silver reflector and lens optic.

Overall diameter 161mm, cut out 147mm diameter. Xicato LED.

Overall height varies in relation to LED lumen output.

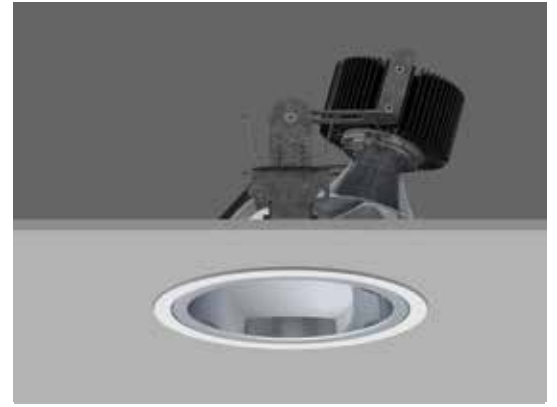

Product No	Luminous Flux (XTM)	Reflector	IP
C4508	Up to 3000 lms	Spectro Silver	IP20
C4608	Up to 3000 lms	Spectro Silver	IP44

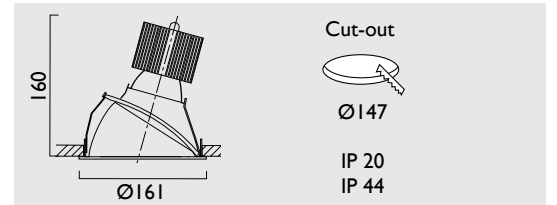

To specify the Light Engine & Driver code please refer to pages 154-155.

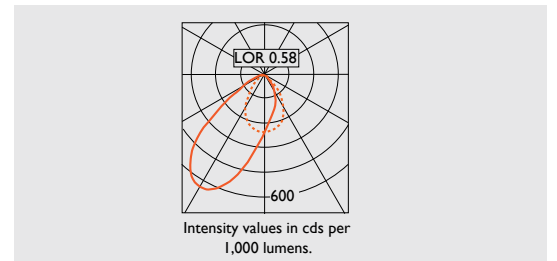

VP X161

DIRECTIONAL

SPECTRO SILVER

VP X161 DIRECTIONAL Round recessed downlighter with white ceiling trim and low glare, deep cone, diffused spectro silver reflector and lens optic. 0-28° lockable tilt, 340° rotation.

Overall diameter 161mm, cut out 147mm diameter. Xicato LED.

Overall height varies in relation to LED lumen output.



Product No	Luminous Flux (XTM)	Reflector	IP
C4708	Up to 3000 lms	Spectro Silver	IP20
C4808	Up to 3000 lms	Spectro Silver	IP44

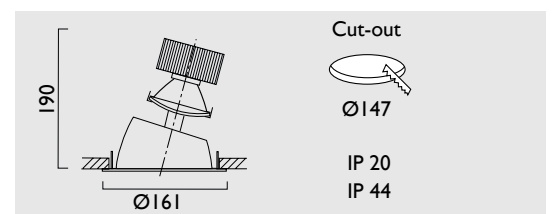

To specify the Light Engine & Driver code please refer to pages 154-155.



Virgin Atlantic Clubhouse,
Hong Kong International Airport
Lighting Design: CLA Hong Kong
Interior Design: HC-STUDIOS

Chek Lap Kok Airport
Architect: Foster+Partners
Lighting Consultant: FMS
Consulting Engineer: Ove Arup

Virgin Atlantic Clubhouse is positioned on the upper level of Terminal 1 in Hong Kong International Airport, known locally as Chek Lap Kok. When first built DAL worked closely with Fisher Marantz Stone (FMS) in the development of 26 different custom luminaire types for the airport, which is still a most prestigious project and one of the largest engineering and architectural developments in the world.

The Clubhouse Bar is a popular place to be with its warm upmarket interior. The sparkling design is set off with AMBIANCE downlighters and is the perfect place for a beer or cocktail prior to boarding your Virgin Atlantic flight.

TRIMLESS

DAL's Trimless Downlighters are designed without the standard mounting trim. Some downlighters have visible return-edge reflector, others have a minimal edge detail. Using the same reflector configuration, the Trimless VP X range is designed to match VP X products. Trimless Downlighters are supplied with plaster-in ceiling kits designed for ceilings with a plaster skim. Other trim and trimless designs could be developed for unusual ceiling types. Please contact us with your requirements.



TRIMLESS KEY FEATURES

Service Life: 50,000 - L70-L80

Incorporating LED manufacturers such as Xicato and Lumileds

Future proofed Zhaga compatible LEDs

Colour Rendering:
Xicato remote phosphor Ra >80 2 Step MacAdam as standard
Ra >95 to special order
Ra > 80 and Ra >90 COB Technology available

Colour Temperatures available:
2700K, 3500, 3000K or 4000K

Standard luminous flux packages currently available: 2000 - 4000 lumens.
For higher lumen output LEDs please contact us.

Passive cooling systems

All products IP 20 minimum

Built to compliance EN 60598-1

Class III construction

Two piece reflector system
Diameters:
80mm, 82mm, 124mm, 140mm

Squares:
53mm, 80mm

Beam angles: Spot, Medium, Flood.
20 - 60 degree

Kick and lens wallwasher reflectors

Lockable directional facility on some products

Dimming protocols:
DALI, 1-10V, Lead/trailing edge

Emergency modes and conversions available

Reflector Finishes:
Black, White, Spectro Silver - a low glare, highly reflectivity, diffused material, offering high performance with visual comfort

Mounting details:
Plaster in ceiling components

Trimless downlighters have matching Trim downlighters

To ensure downlighter heights and ceilings are compatible on-site recess depths should be checked.

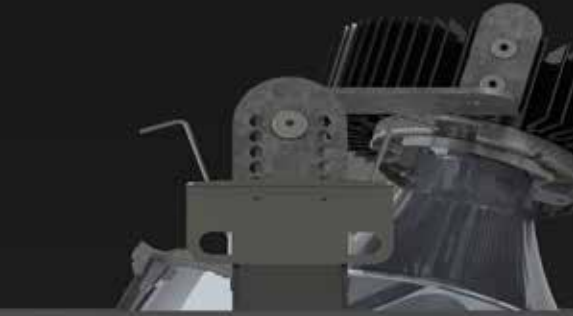

Reflector cut-edge detail



Return-edge reflector detail

- TRIMLESS AMBIANCE X53 SQUARE
- TRIMLESS AMBIANCE X80 SQUARE
- TRIMLESS AMBIANCE X80
- TRIMLESSVP X82
- TRIMLESSVP X124
- TRIMLESSVP X140

FIXED DOWNLIGHTER	TRIMLESS AMBIANCE X53 SQUARE	TRIMLESS AMBIANCE X80 SQUARE	TRIMLESS AMBIANCE X80	TRIMLESSVP X82	TRIMLESSVP X124	TRIMLESSVP X140
KICK WALLWASHER	●	●	●	●	●	●
KICK DOUBLE WALLWASHER				●	●	
KICK CORNER WALLWASHER					●	●
LENS WALLWASHER			●	●	●	
DIRECTIONAL TILT			●	●	●	
Up to 1300lms	●					
Up to 2000lms		●	●	●	●	●
Up to 3000lms				●	●	

TRIMLESS AMBIANCE X53 SQUARE

BLACK, WHITE

TRIMLESS AMBIANCE X53 SQUARE FIXED Recessed downlighter; designed for plaster skim ceilings with a choice of deep baffle finish, lens optic and beam distribution. Overall size 53mm x 53mm, cut out 70mm x 70mm. Xicato LED.

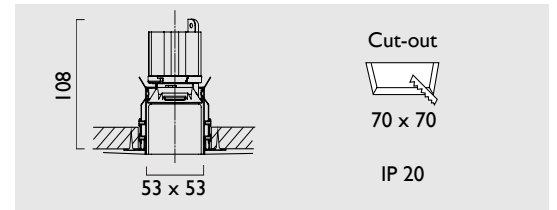
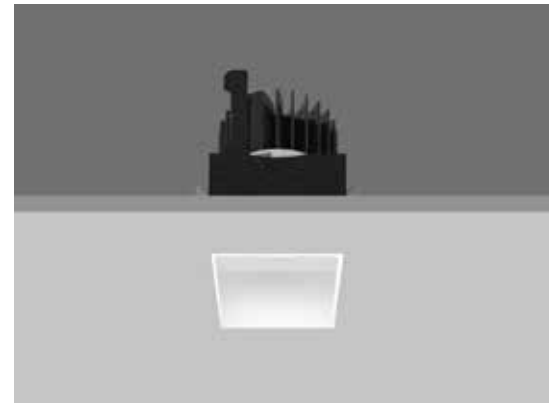

Beam	Black	White
Light Fixture IP20 - Up to 720 lms		
30°	F0733	F0734
40°	F0743	F0744

To specify the Light Engine & Driver code please refer to pages 154-155.

TRIMLESS AMBIANCE X80 SQUARE

BLACK, WHITE

TRIMLESS AMBIANCE X80 SQUARE FIXED, square, recessed downlighter; designed for plaster skim ceilings with a choice of deep baffle finish and beam distribution. Overall size 80mm x 80mm, cut out 95mm x 95mm. Xicato LED.

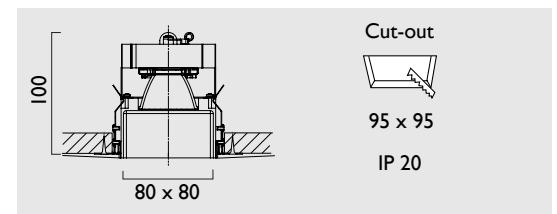

Beam	Black	White
Light Fixture IP20 - Up to 2000 lms (XTM)		
40°	F1143	F1144
60°	F1163	F1164

To specify the Light Engine & Driver code please refer to pages 154-155.

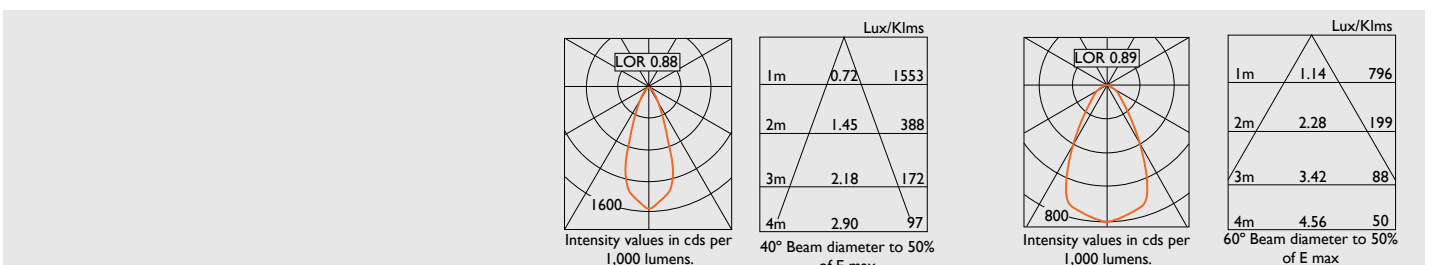

TRIMLESS

TRIMLESS AMBIANCE X80

WHITE

TRIMLESS AMBIANCE X80 FIXED Round recessed downlighter; designed for plaster skim ceilings with white deep cone reflector and a choice of beam distribution. Overall diameter 80mm, cut out 82mm diameter. Xicato LED.

Beam	Product No
Light Fixture IP20 - Up to 2000 lms (XTM)	
20°	G2024
60°	G2064

To specify the Light Engine & Driver code please refer to pages 154-155.

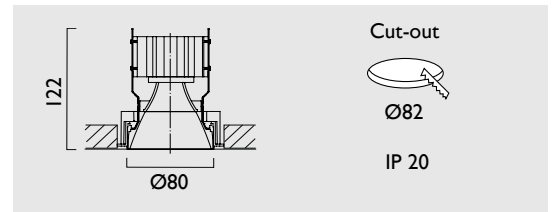

TRIMLESS AMBIANCE X80 LENS WALLWASHER

WHITE

TRIMLESS AMBIANCE X80 LENS WALLWASHER Round recessed, designed for plaster skim ceilings with white deep cone reflector and lens optic. Overall diameter 80mm, cut out 82mm diameter. Xicato LED.

Product No
Light Fixture IP20 - Up to 2000 lms (XTM)
G2204

To specify the Light Engine & Driver code please refer to pages 154-155.

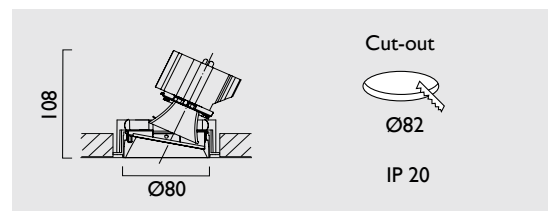

TRIMLESS AMBIANCE X80 DIRECTIONAL

WHITE

TRIMLESS AMBIANCE X80 DIRECTIONAL Round recessed downlighter, designed for plaster skim ceilings with white deep cone reflector and a choice of beam distribution. Overall diameter 80mm, cut out 82mm diameter. Xicato LED.

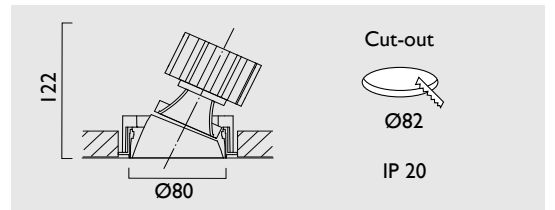
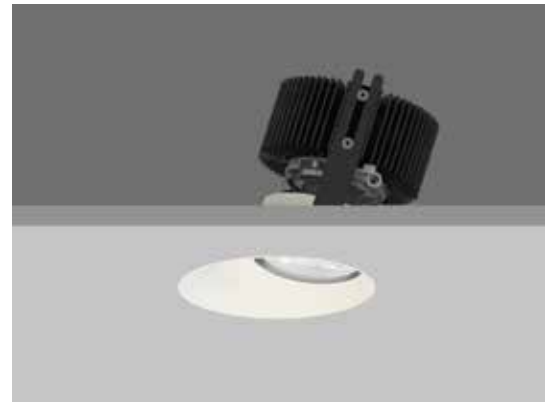

Beam	Product No
Light Fixture IP20 - Up to 2000 lms (XTM)	
20°	G2424
60°	G2464

To specify the Light Engine & Driver code please refer to pages 154-155.

TRIMLESS

TRIMLESS VP X82

SPECTRO SILVER

TRIMLESS VP X82 FIXED Round recessed downlighter, designed for plaster skim ceilings with low glare, deep cone, diffused spectro silver reflector and lens optic. Overall diameter 82mm, cut out 100mm diameter. Xicato LED.

Product No	Luminous Flux (XTM)	Reflector	IP
C4908	Up to 2000 lms	Spectro Silver	IP20

To specify the Light Engine & Driver code please refer to pages 154-155.

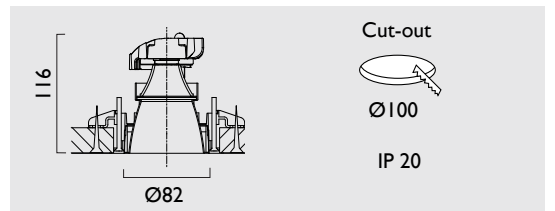
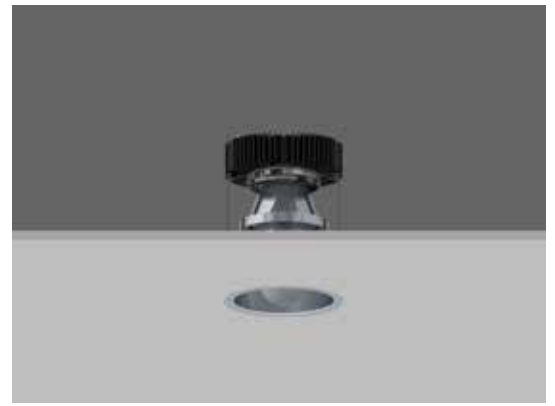

TRIMLESS VP X82 KICK WALLWASHER

TRIMLESS VP X82 KICK WALLWASHER FIXED Round recessed wallwasher designed for plaster skim ceilings with low glare, deep cone, diffused spectro silver reflector and lens optic. Overall diameter 82mm, cut out 100mm diameter. Xicato LED.

Product No	Luminous Flux (XTM)	Reflector	IP
F4508	Up to 2000 lms	Spectro Silver	IP20

To specify the Light Engine & Driver code please refer to pages 154-155.

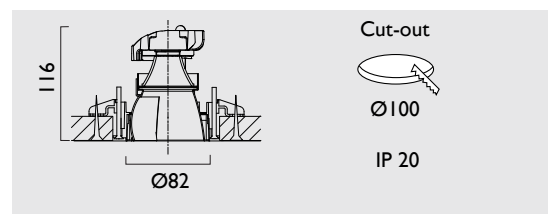

TRIMLESS VP X124

SPECTRO SILVER

TRIMLESS VP X124 FIXED Round recessed downlighter, designed for plaster skim ceilings with low glare, deep cone, diffused spectro silver reflector and lens optic.
 Overall diameter 124mm, cut out 140mm diameter. Xicato LED.
 Overall height varies in relation to LED lumen output.



Product No	Luminous Flux (XTM)	Reflector	IP
C5108	Up to 2000 lms	Spectro Silver	IP20
F6608	Up to 3000 lms	Spectro Silver	IP20

To specify the Light Engine & Driver code please refer to pages 154-155.

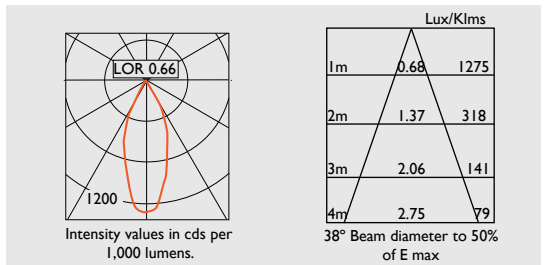
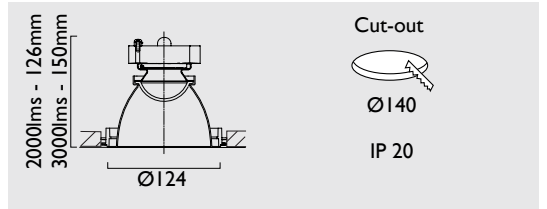

TRIMLESS VP X124 KICK WALLWASHER

SPECTRO SILVER

TRIMLESS VP X124 KICK WALLWASHER FIXED, Round recessed wallwasher designed for plaster skim ceilings with low glare, deep cone, diffused spectro silver reflector and lens optic.
 Overall diameter 124mm, cut out 140mm diameter. Xicato LED.
 Overall height varies in relation to LED lumen output.



Product No	Luminous Flux (XTM)	Reflector	IP
C5308	Up to 2000 lms	Spectro Silver	IP20
F6808	Up to 3000 lms	Spectro Silver	IP20

To specify the Light Engine & Driver code please refer to pages 154-155.

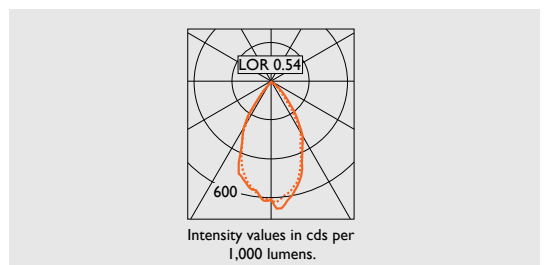
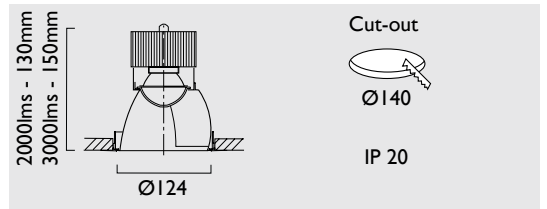

TRIMLESS

TRIMLESS VP X124 CORNER WALLWASHER

SPECTRO SILVER

TRIMLESS VP X124 CORNER KICK WALLWASHER FIXED Round recessed wallwasher designed for plaster skim ceilings with low glare, deep cone, diffused spectro silver reflector and lens optic.

Overall diameter 124mm, cut out 140mm diameter. Xicato LED.

Overall height varies in relation to LED lumen output.

Product No	Luminous Flux (XTM)	Reflector	IP
C5508	Up to 2000 lms	Spectro Silver	IP20
F7008	Up to 3000 lms	Spectro Silver	IP20

To specify the Light Engine & Driver code please refer to pages 154-155.

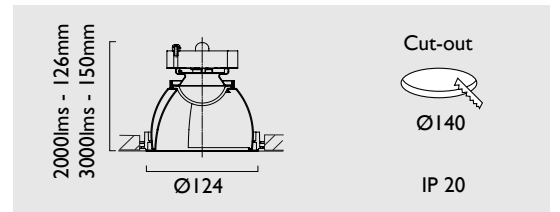

TRIMLESS VP X124 DOUBLE WALLWASHER

SPECTRO SILVER

TRIMLESS VP X124 DOUBLE KICK WALLWASHER FIXED Round recessed wallwasher designed for plaster skim ceilings with low glare, deep cone, diffused spectro silver reflector and lens optic.

Overall diameter 124mm, cut out 140mm diameter. Xicato LED.

Overall height varies in relation to LED lumen output.

Product No	Luminous Flux (XTM)	Reflector	IP
C5708	Up to 2000 lms	Spectro Silver	IP20
F7208	Up to 3000 lms	Spectro Silver	IP20

To specify the Light Engine & Driver code please refer to pages 154-155.

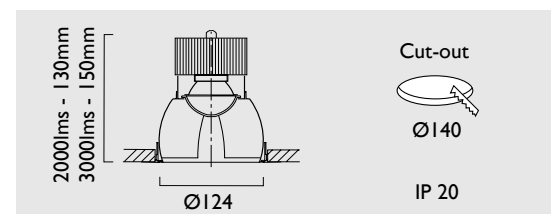

TRIMLESS VP X124 LENS WALLWASHER

SPECTRO SILVER

TRIMLESS VP X124 LENS WALLWASHER FIXED Round recessed wallwasher designed for plaster skim ceilings with low glare, deep cone, diffused spectro silver reflector and lens optic.

Overall diameter 124mm, cut out 140mm diameter. Xicato LED.

Overall height varies in relation to LED lumen output.

Product No	Luminous Flux (XTM)	Reflector	IP
C5908	Up to 2000 lms	Spectro Silver	IP20
F7408	Up to 3000 lms	Spectro Silver	IP20

To specify the Light Engine & Driver code please refer to pages 154-155.

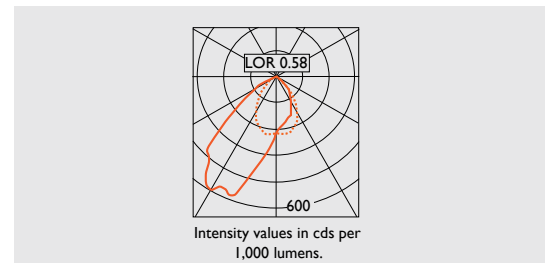
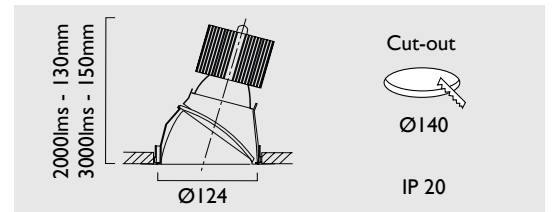
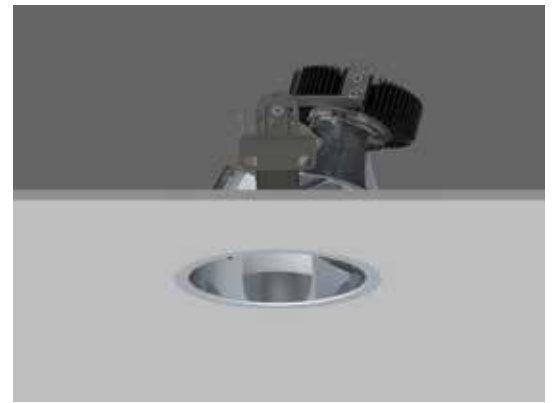

TRIMLESS VP X124 DIRECTIONAL

SPECTRO SILVER

TRIMLESS VP X124 DIRECTIONAL Round recessed downlighter; designed for plaster skim ceilings with low glare, deep cone, diffused spectro silver reflector and lens optic. 0-28° tilt, 340° rotation.

Overall diameter 124mm, cut out 140mm diameter. Xicato LED.

Overall height varies in relation to LED lumen output.

Product No	Luminous Flux (XTM)	Reflector	IP
C6108	Up to 2000 lms	Spectro Silver	IP20
F7608	Up to 3000 lms	Spectro Silver	IP20

To specify the Light Engine & Driver code please refer to pages 154-155.

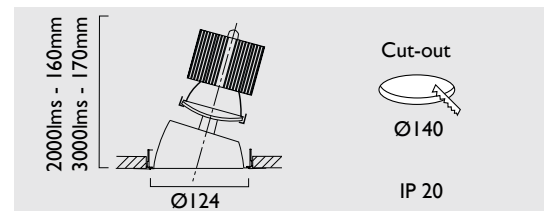
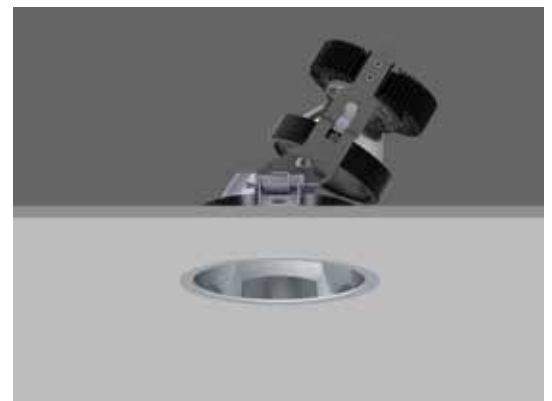

TRIMLESS

TRIMLESS VP XI 40

SPECTRO SILVER

TRIMLESS VP XI 40 FIXED Round recessed downlighter, designed for plaster skim ceilings with low glare, deep cone, diffused spectro silver reflector and lens optic. Overall diameter 140mm, cut out 156mm diameter. Xicato LED.

Product No	Luminous Flux (XTM)	Reflector	IP
C6308	Up to 3000 lms	Spectro Silver	IP20

To specify the Light Engine & Driver code please refer to pages 154-155.

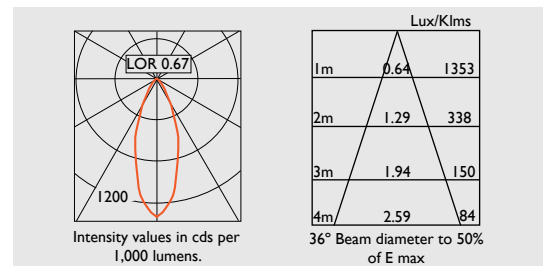
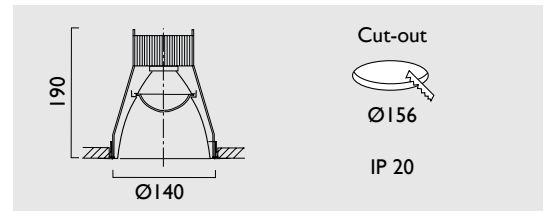

TRIMLESS VP XI 40 KICK WALLWASHER

SPECTRO SILVER

TRIMLESS VP XI 40 KICK WALLWASHER FIXED Round recessed wallwasher designed for plaster skim ceilings with low glare, deep cone, diffused spectro silver reflector and lens optic. Overall diameter 140mm, cut out 156mm diameter. Xicato LED.

Product No	Luminous Flux (XTM)	Reflector	IP
C6508	Up to 3000 lms	Spectro Silver	IP20

To specify the Light Engine & Driver code please refer to pages 154-155.

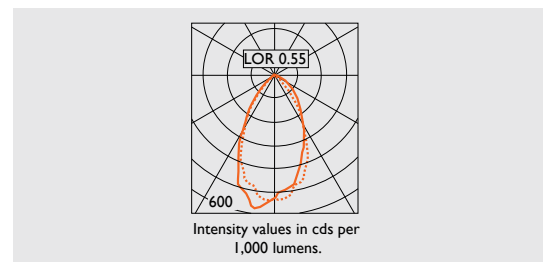
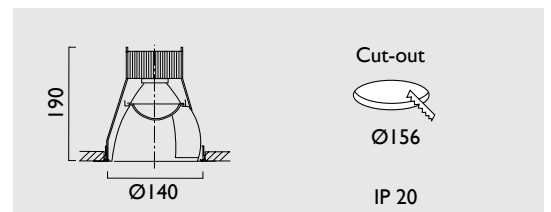

TRIMLESS VP XI 40 LENS WALLWASHER

SPECTRO SILVER

TRIMLESS VP XI 40 LENS WALLWASHER FIXED Round recessed wallwasher designed for plaster skim ceilings with low glare, deep cone, diffused spectro silver reflector and lens optic.

Overall diameter 140mm, cut out 156mm diameter. Xicato LED.

Product No	Luminous Flux (XTM)	Reflector	IP
C6708	Up to 3000 lms	Spectro Silver	IP20

To specify the Light Engine & Driver code please refer to pages 154-155.

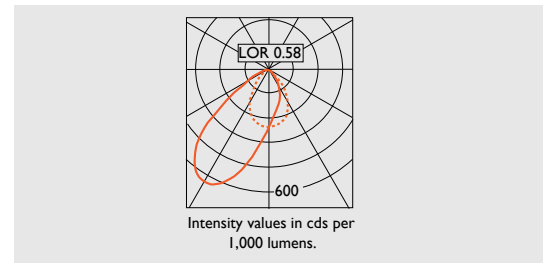
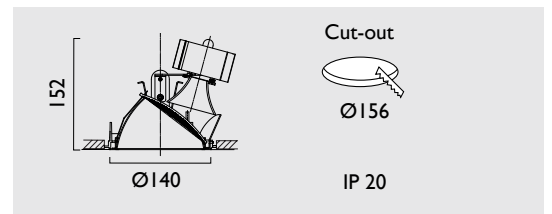
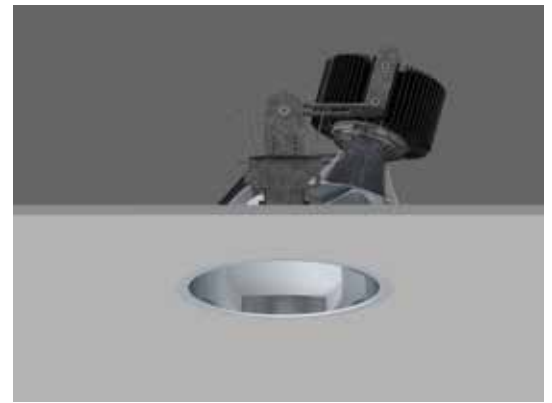

TRIMLESS VP XI 40 DIRECTIONAL

SPECTRO SILVER

TRIMLESS VP XI 40 DIRECTIONAL Round recessed downlighter; designed for plaster skim ceilings with low glare, deep cone, diffused spectro silver reflector and lens optic. 0-28° tilt, 340° rotation.

Overall diameter 140mm, cut out 156mm diameter. Xicato LED.

Product No	Luminous Flux (XTM)	Reflector	IP
C6908	Up to 3000 lms	Spectro Silver	IP20

To specify the Light Engine & Driver code please refer to pages 154-155.

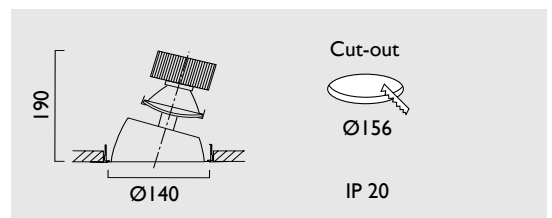



Brent Civic Centre, Wembley
Architect: Hopkins Architects
Electrical and lighting specialists:
URS Scott Wilson
Main Contractor: Skanska
M&E Contractor: Skanska

Brent Civic Centre is one of the many new buildings in the regeneration of the Wembley Park area. Wembley has a long history of unique and interesting building designs, including the relatively new Foster Architect's 2007 stadium with its iconic soaring arch. Also, there is the legacy of the original stadium built in 1923 for the Empire Exhibition; the twin towers etched in the psyche of almost every English football fan.

Part of the Civic Centre's innovative design is a naturally-lit foyer and atrium, this houses a large amphitheatre suitable for public performances and events.

Over 2000 DAL CIVIC G210 surface mounted downlighters and TEMPO 161 recessed downlighters were supplied for the project

SHALLOW DEPTH

DAL's Shallow Depth range offers a choice of beam distributions and reflector finishes combined with excellent luminaire efficiency and high output LEDs. They are ideal for perimeter and core office areas, corridors and washrooms; areas requiring uniform illumination with good glare control. They are also a perfect choice for shopping centres and retail lighting; areas where an efficient downlighter is needed for general ambient level lighting. Their shallow depth and IP44 rating gives scope for many applications. Available in circular and square construction with downlighter and wall wash options.



TEMPO X161

SPECULAR SILVER, SATIN SILVER, WHITE

TEMPO X161 FIXED Round recessed downlighter with standard white ceiling trim and a choice of reflector finish and beam distribution.
Overall diameter 161mm, cut out 147mm diameter. Xicato LED.



Beam Angle	Specular Silver	Satin Silver	White
Light Fixture IP20 - Up to 3000 lms			
20°	C7121	C7122	C7124
40°	C7141	C7142	C7144
60°	C7161	C7162	C7164

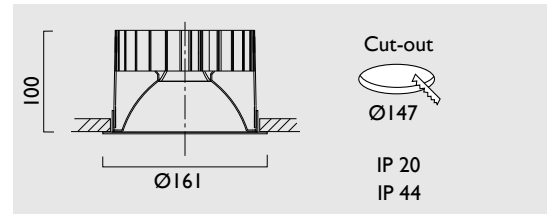

Light Fixture IP44 - Up to 3000 lms			
20°	C7221	C7222	C7224
40°	C7241	C7242	C7244
60°	C7261	C7262	C7264

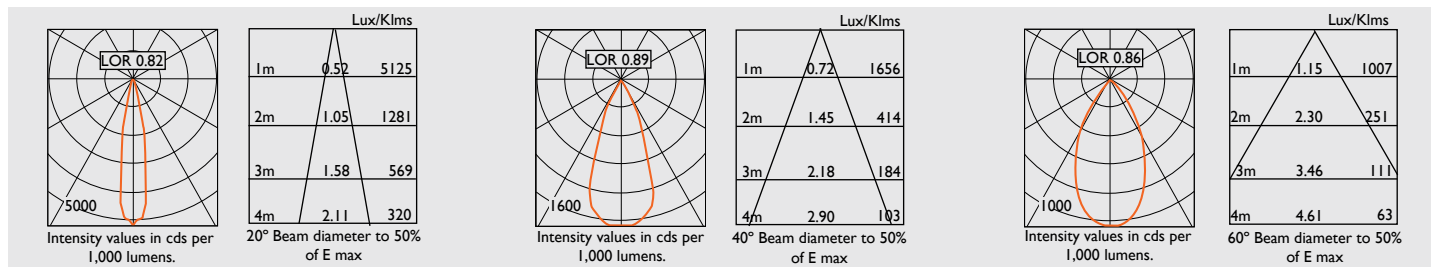

To specify the Light Engine & Driver code please refer to pages 154-155.



TEMPO X161 downlighters IP20 trim detail and reflector finishes.



TEMPO X161 downlighters IP44 trim detail and reflector finishes.

TEMPO X161 80°

SATIN SILVER

TEMPO X161 80° FIXED Round recessed downlighter with standard white ceiling trim, satin silver reflector finish.

Overall diameter 161mm, cut out 147mm diameter. Xicato LED.



Product No	Beam Angle	Luminous Flux (XTM)	Reflector	IP
C7581	80°	Up to 3000 lms	Satin Silver	IP20
C7681	80°	Up to 3000 lms	Satin Silver	IP44

To specify the Light Engine & Driver code please refer to pages 154-155.

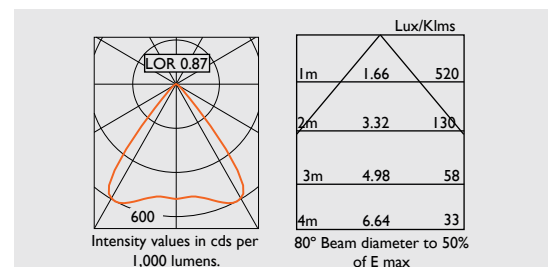
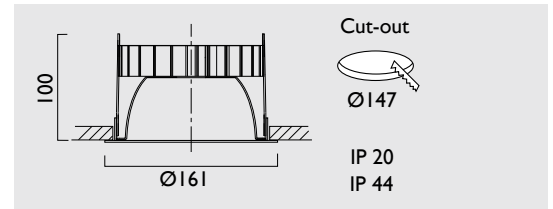

SHALLOW DEPTH

TEMPO X161

LENS WALLWASHER

SPECULAR SILVER

TEMPO X161 LENS WALLWASHER FIXED Round recessed wallwasher with standard white ceiling trim, specular silver reflector finish, eye-led baffle and lens optic. Overall diameter 161mm, cut out 147mm diameter. Xicato LED.

Product No	Luminous Flux (XTM)	Reflector	IP
C7901	Up to 2000 lms	Specular Silver	IP20

To specify the Light Engine & Driver code please refer to pages 154-155.

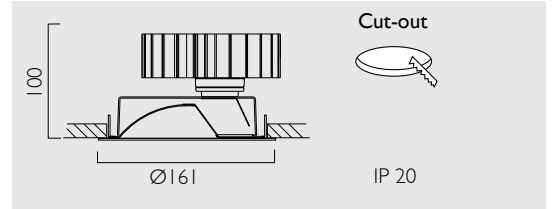
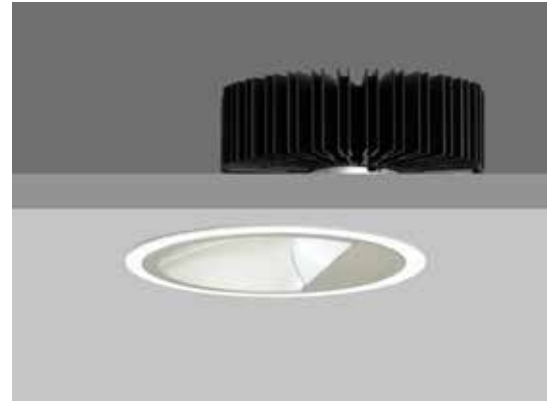

AMPIA X161

SPECULAR SILVER

AMPIA X161 FIXED Round recessed downlighter with standard white ceiling trim, specular silver reflector and lens optic. Overall diameter 161mm, cut out 147mm diameter. Xicato LED.

Product No	Luminous Flux (XTM)	Reflector	IP
C8101	Up to 2000 lms	Specular Silver	IP20

To specify the Light Engine & Driver code please refer to pages 154-155.

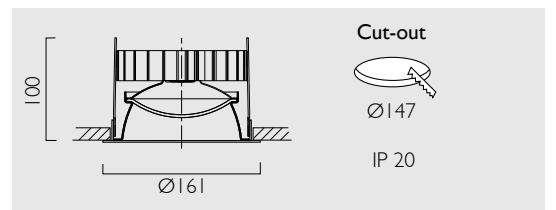

ICE XI61

WHITE

ICE XI61 FIXED Round recessed downlighter with standard white ceiling trim, white reflector finish and stippled acrylic diffusing cover.
Overall diameter 161mm, cut out 147mm diameter. Xicato LED.

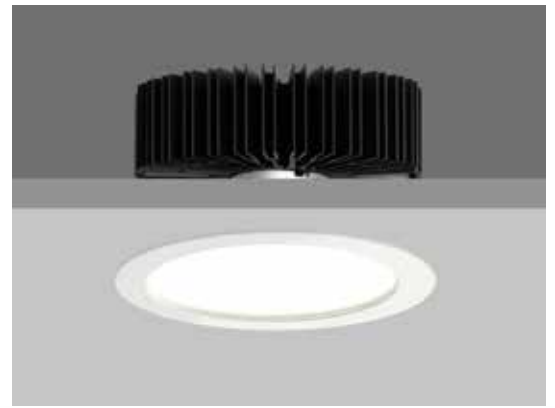

Product No	Luminous Flux (XTM)	Reflector	IP
C8401	Up to 2000 lms	White	IP44

To specify the Light Engine & Driver code please refer to pages 154-155.

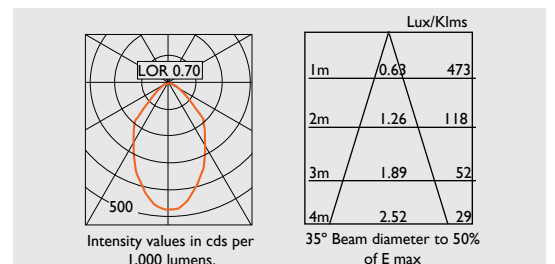
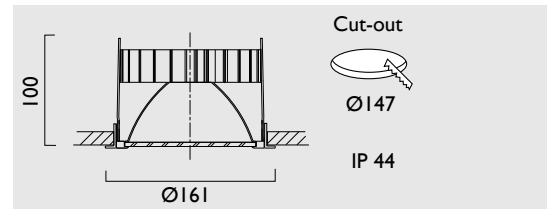

SQUARE X161

SPECULAR SILVER

SQUARE X161 Fixed recessed downlighter with standard white ceiling trim, specular reflector and a choice of beam distribution.

Overall size 161mm x 161mm, cut out 147mm x 147mm. Xicato LED.



Product No	Beam Angle	Luminous Flux (XTM)	Reflector	IP
C8727	20°	Up to 3000 lms	Specular Silver	IP20
C8747	40°	Up to 3000 lms	Specular Silver	IP20
C8767	60°	Up to 3000 lms	Specular Silver	IP20
C8827	20°	Up to 3000 lms	Specular Silver	IP44
C8847	40°	Up to 3000 lms	Specular Silver	IP44
C8867	60°	Up to 3000 lms	Specular Silver	IP44

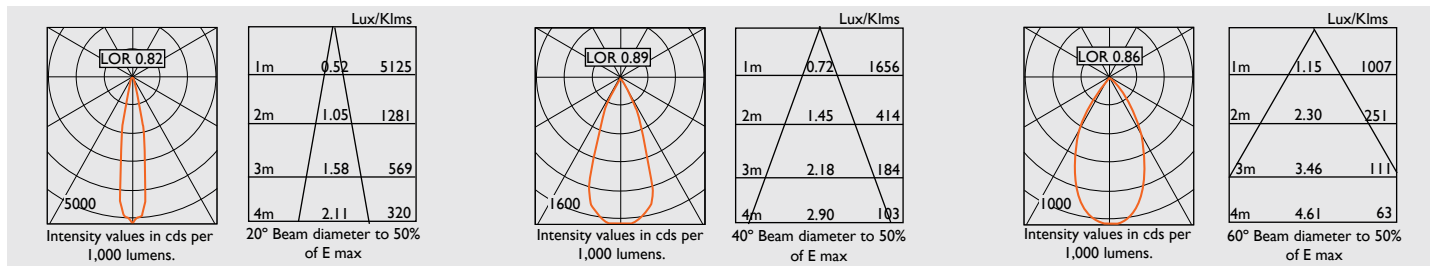
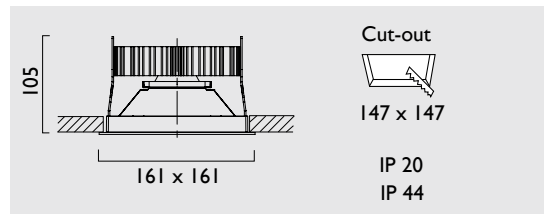

To specify the Light Engine & Driver code please refer to pages 154-155.

SQUARE X161 LENS WALLWASHER

SPECULAR SILVER

SQUARE X161 LENS WALLWASHER FIXED Recessed wallwasher with standard white ceiling trim, specular silver reflector and lens optic.

Overall size 161mm x 161mm, cut out 147mm x 147mm. Xicato LED.

Product No	Luminous Flux (XTM)	Reflector	IP
C9107	Up to 2000 lms	Specular Silver	IP20
C9207	Up to 2000 lms	Specular Silver	IP44

To specify the Light Engine & Driver code please refer to pages 154-155.

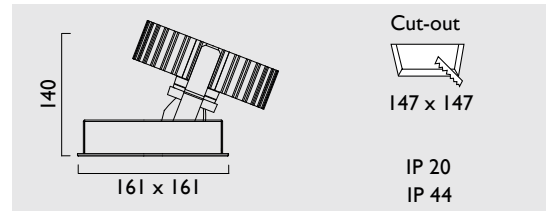

SQUARE X161 DIRECTIONAL

SPECULAR SILVER

SQUARE X161 DIRECTIONAL Recessed downlighter with standard white ceiling trim and specular silver reflector: 0-28° tilt, 340° rotation.

Overall size 161mm x 161mm, cut out 147mm x 147mm. Xicato LED.

Product No	Beam Angle	Luminous Flux (XTM)	Reflector	IP
C8927	20°	Up to 3000 lms	Specular Silver	IP20
C8947	40°	Up to 3000 lms	Specular Silver	IP20
C8967	60°	Up to 3000 lms	Specular Silver	IP20
C9027	20°	Up to 3000 lms	Specular Silver	IP44
C9047	40°	Up to 3000 lms	Specular Silver	IP44
C9067	60°	Up to 3000 lms	Specular Silver	IP44

To specify the Light Engine & Driver code please refer to pages 154-155.

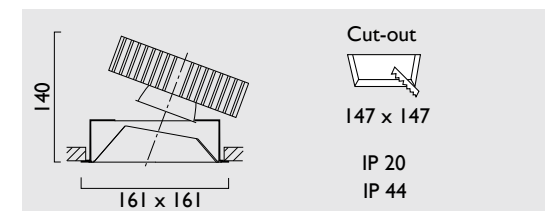



The Drum events and meetings venue, Brent Civic Centre



The Library, Brent Civic Centre

Brent Civic Centre, Wembley
Architect: Hopkins Architects
Electrical and lighting specialists:
URS Scott Wilson
Main Contractor: Skanska
M & E Contractor: Skanska

The new Civic Centre incorporates the Council's main administration offices together with a Civic Chamber for council meetings, Wembley Public Library, marriage suites and a grand banqueting hall. The aim is to provide a hub and heart for the community where residents can meet, shop and eat. With its internal amphitheatre a programme of high-quality arts and cultural experiences happen regularly.

As one of the most sustainable local authority building completed in the UK it features a combination of solar shading, natural ventilation, a high-performance façade and a combined cooling, heating and power system which utilises waste vegetable oil.

SURFACE MOUNTED

DAL's Civic and Surface VP downlighters are a perfect solution for buildings where recessed mounting is not possible. A choice of LED lumen packages and light distributions offers the solution for many lighting projects. Surface VP can answer a variety of building constraints because they match recessed VP Trim and Trimless downlighter ranges.



SURFACE MOUNTED

CIVIC X65

SPECULAR SILVER

CIVIC X65 Surface mounted downlighter with deep cone specular silver reflector and a choice of white or black casing. Driver mounted remotely. Overall diameter 65mm. Height 140mm. Xicato LED.



Product No	Beam Angle	Luminous Flux (XTM)	Reflector	IP
RAL 9010 White Casing				
F4141	40°	Up to 965lms	Specular Silver	IP20
RAL 9005 Black Casing				
F4241	40°	Up to 965lms	Specular Silver	IP20

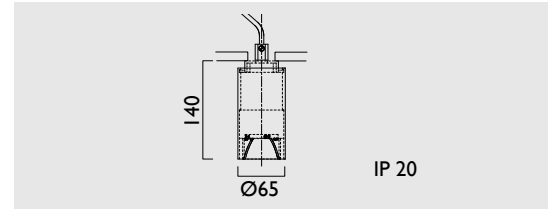

Please contact us for further beam spread option.

To specify the Light Engine & Driver code please refer to pages 154-155.

Some CIVIC downlighters are also available with pendant suspensions or wall-mounting side arms.

CIVIC X102

SPECULAR SILVER

CIVIC X102 Surface mounted downlighter with deep cone specular silver reflector and with white or black casing. Driver mounted remotely. Overall diameter 102mm. Height 140mm. Xicato LED.



Product No	Beam Angle	Luminous Flux (XTM)	Reflector	IP
RAL 9010 White Casing				
C9321	20°	Up to 2000lms	Specular Silver	IP20
C9341	40°	Up to 2000lms	Specular Silver	IP20
C9361	60°	Up to 2000lms	Specular Silver	IP20
RAL 9005 Black Casing				
C9421	20°	Up to 2000lms	Specular Silver	IP20
C9441	40°	Up to 2000lms	Specular Silver	IP20
C9461	60°	Up to 2000lms	Specular Silver	IP20

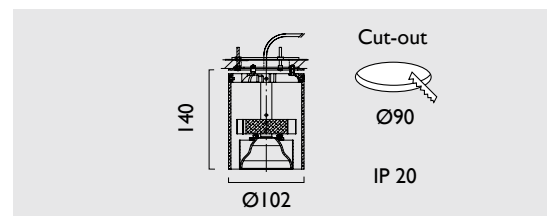

For higher output engines e.g. lumens, please contact us for availability.

To specify the Light Engine & Driver code please refer to pages 154-155.

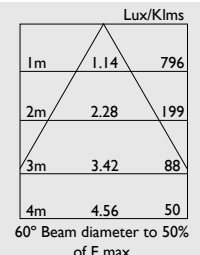
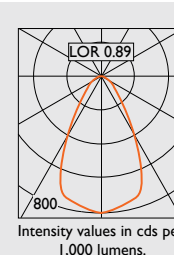
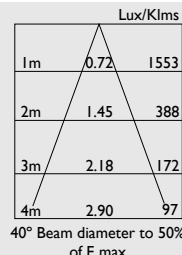
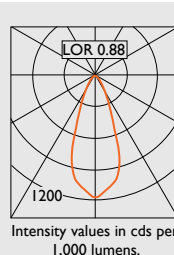

CIVIC X102

DIRECTIONAL

SPECULAR SILVER

CIVIC X102 DIRECTIONAL Surface mounted downlighter with deep cone specular silver reflector and with white or black casing. 0-15° tilt. Driver mounted remotely. Overall diameter 102mm. Height 140mm. Xicato LED.

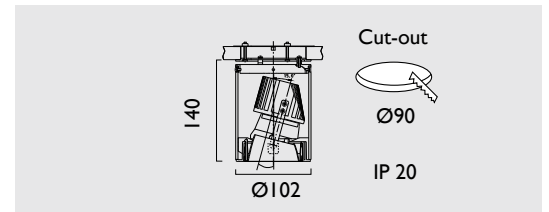

Product No	Beam Angle	Luminous Flux (XTM)	Reflector	IP
RAL 9010 White Casing				
F4321	20°	Up to 2000lms	Specular Silver	IP20
F4341	40°	Up to 2000lms	Specular Silver	IP20
F4361	60°	Up to 2000lms	Specular Silver	IP20
RAL 9005 Black Casing				
F4421	20°	Up to 2000lms	Specular Silver	IP20
F4441	40°	Up to 2000lms	Specular Silver	IP20
F4461	60°	Up to 2000lms	Specular Silver	IP20

To specify the Light Engine & Driver code please refer to pages 154-155.

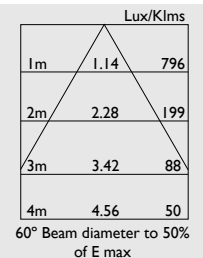
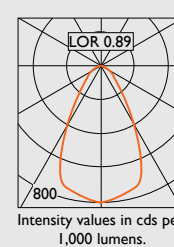
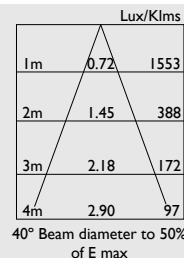
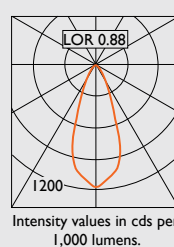

CIVIC X165

SPECULAR SILVER, SATIN SILVER, WHITE

CIVIC X165 Surface mounted downlighter with a choice of deep cone reflector finish and beam distribution and with black RAL 9005 casing. Driver mounted integrally. Overall diameter 165mm. Height 230mm. Xicato LED.

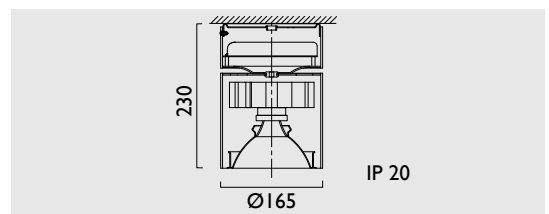

Beam Angle	Specular Silver	Satin Silver	White
Light Fixture IP20 - Up to 3000 ms (XTM)			
20°	C9521	C9522	C9524
40°	C9541	C9542	C9544
60°	C9561	C9562	C9564

To specify the Light Engine & Driver code please refer to pages 154-155.

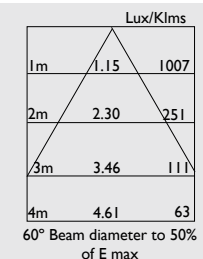
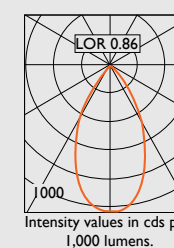
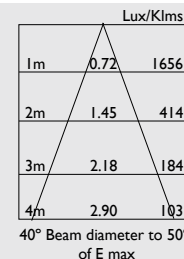
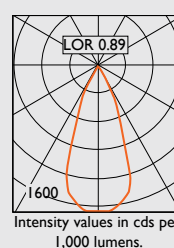
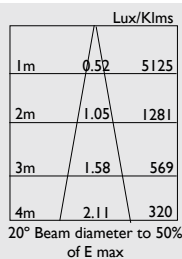
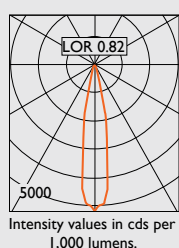

SURFACE VP XI 40

SPECTRO SILVER

SURFACEVP XI40 Surface mounted fixed, round downlighter with low glare, deep cone, diffused spectro silver reflector and lens optic and with white casing. Driver mounted remotely.

Overall diameter 140mm. Height 146mm. Xicato LED.

Product No	Luminous Flux (XTM)	Reflector	IP
H0107	Up to 2000 lms	Spectro Silver	IP20

To specify the Light Engine & Driver code please refer to pages 154-155.

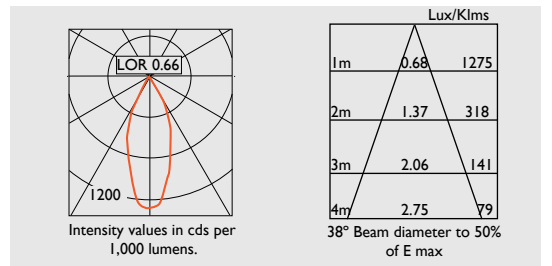
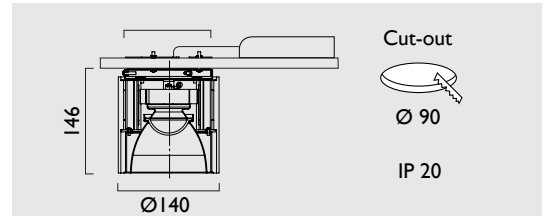

SURFACE VP XI 40 KICK WALLWASHER

SPECTRO SILVER

SURFACE VP XI40 KICK WALLWASHER Surface mounted fixed, round wallwasher with low glare, deep cone, diffused spectro silver reflector and lens optic and with white casing. Driver mounted remotely.

Overall diameter 140mm. Height 146mm. Xicato LED.

Product No	Luminous Flux (XTM)	Reflector	IP
H0207	Up to 2000 lms	Spectro Silver	IP20

To specify the Light Engine & Driver code please refer to pages 154-155.

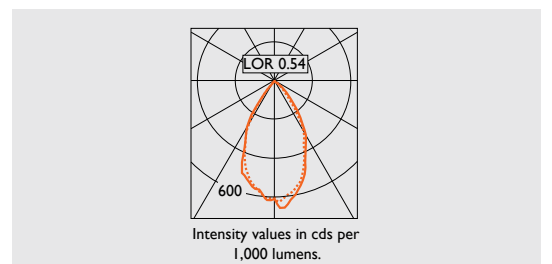
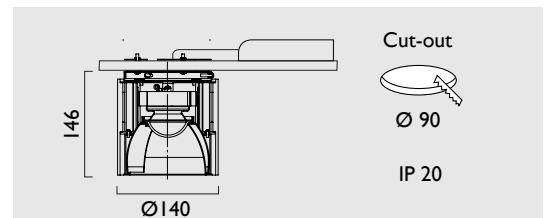

Some SURFACEVP downlighters are also available with pendant suspensions or wall-mounting side arms.

SURFACE VP X140

DIRECTIONAL

SPECTRO SILVER

SURFACE VP X140 DIRECTIONAL Surface mounted, round directional downlighter with low glare, deep cone, diffused spectro silver reflector and lens optic and with white casing. Driver mounted integrally. 0-28° tilt. Overall diameter 140mm. Height 260mm. Xicato LED.

Product No	Luminous Flux (XTM)	IP
H0301	Up to 2000 lms	IP20

To specify the Light Engine & Driver code please refer to pages 154-155.

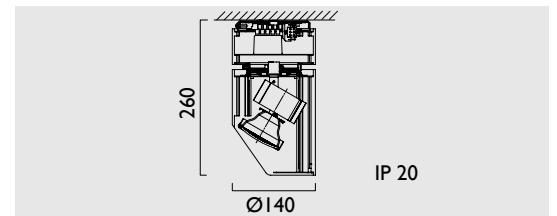

SURFACE VP X161

SPECTRO SILVER

SURFACE VP X161 Surface mounted fixed, round downlighter with low glare, deep cone, diffused spectro silver reflector and lens optic and with white casing. Driver mounted integrally. Overall diameter 161mm. Height 276mm. Xicato LED.

Product No	Luminous Flux (XTM)	Reflector	IP
H0707	Up to 2000 lms	Spectro Silver	IP20

To specify the Light Engine & Driver code please refer to pages 154-155.

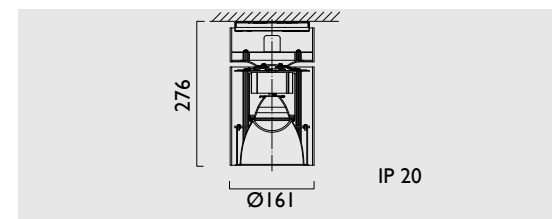

Some SURFACE VP downlighters are also available with pendant suspensions or wall-mounting side arms.





The Imperial War Museum,
London
Lighting Consultant:
George Sexton Associates
Architect: Foster + Partners

More than 400 objects and artworks are displayed in the new galleries split over four levels. However, it is the Harrier jet, the Supermarine Spitfire, and the German V1 flying bomb suspended from the ceiling that continues to give the wow factor. Another iconic object sores into in to space, the Second World War V2 rocket which measures over 14 metres in height. More recent conflicts are recognised with Jeremy Deller's It Is What It Is, the

wreckage of a car destroyed in Baghdad in 2007 when a truck bomb was detonated in busy market place. The change in emphasis and volume of the remodelled space allows a more dramatic framework for all of these exhibits.

For the stairs CIVIC XI02 Surface Downlighters were specified, their compact size and low brightness light control were ideal for the installation.

SURFACE VP X161 KICK WALLWASHER

SPECTRO SILVER

SURFACE VP X161 KICK WALLWASHER Surface mounted fixed, round wallwasher with low glare, deep cone, diffused spectro silver reflector and lens optic and with white casing. Driver mounted integrally.
Overall diameter 161mm. Height 276mm. Xicato LED.

Product No	Beam Angle	Luminous Flux (XTM)	Reflector	IP
H0807		Up to 2000 lms	Spectro Silver	IP20

To specify the Light Engine & Driver code please refer to pages 154-155.

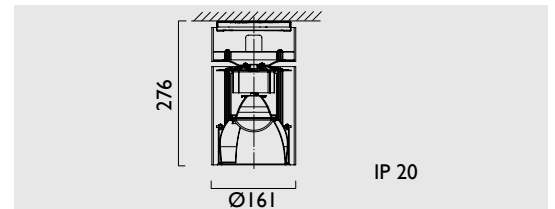

CIVIC G210

SATIN SILVER

CIVIC G210 Surface mounted downlighter with a deep cone satin silver reflector and a choice of beam distribution and silver grey casing (RAL 9006). Driver mounted integrally.
Overall diameter 210mm. Height 305mm. COB LED Technology.

Product No	Beam Angle	Luminous Flux	Reflector	IP
C9732	Spot	Up to 6000 lms	Satin Silver	IP44
C9752	Medium	Up to 6000 lms	Satin Silver	IP44
C9762	Flood	Up to 6000 lms	Satin Silver	IP44

To specify the Light Engine & Driver code please refer to pages 154-155.

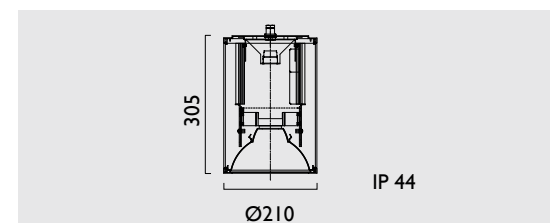

Some CIVIC downlighters are also available with pendant suspensions or wall-mounting side arms.

Higher IP ratings are available





Miller Insurance, 70, Mark Lane, City of London
Consulting Engineer: Hurley Palmer Flatt
Architect: Bennetts Associates



Network Rail, One Eversholt Street, London
Consulting Engineer: Hurley Palmer Flatt

One Eversholt Street was originally designed by Richard Seifert & Partners and is part of the controversial 1970s redevelopment of Euston Station. The earlier Victorian station and the iconic Euston Arch were demolished during the 1960s.

The Network Rail offices are only a small part of the vast infrastructure needed for the company that runs, maintains and develops Britain's railway tracks. Approximately 1.3 billion journeys are made on Britain's 20,000 miles of rail network every year and that's not including the 100 million tonnes of freight that's transported across the UK.

OFFICE

DAL has an outstanding range of luminaires for open plan and cellular office areas. The ATELIER FRAME, ATELIER PANEL and ATELIER PLUS are ideal for modular and grid ceilings. LIGHTLINE offers another luminaire design solution for offices, those requiring continuous lines of light either recessed or suspended. Whether the interior requires a highly technical low glare fixture or a more relaxed specification there will be a product in the DAL range to suit.

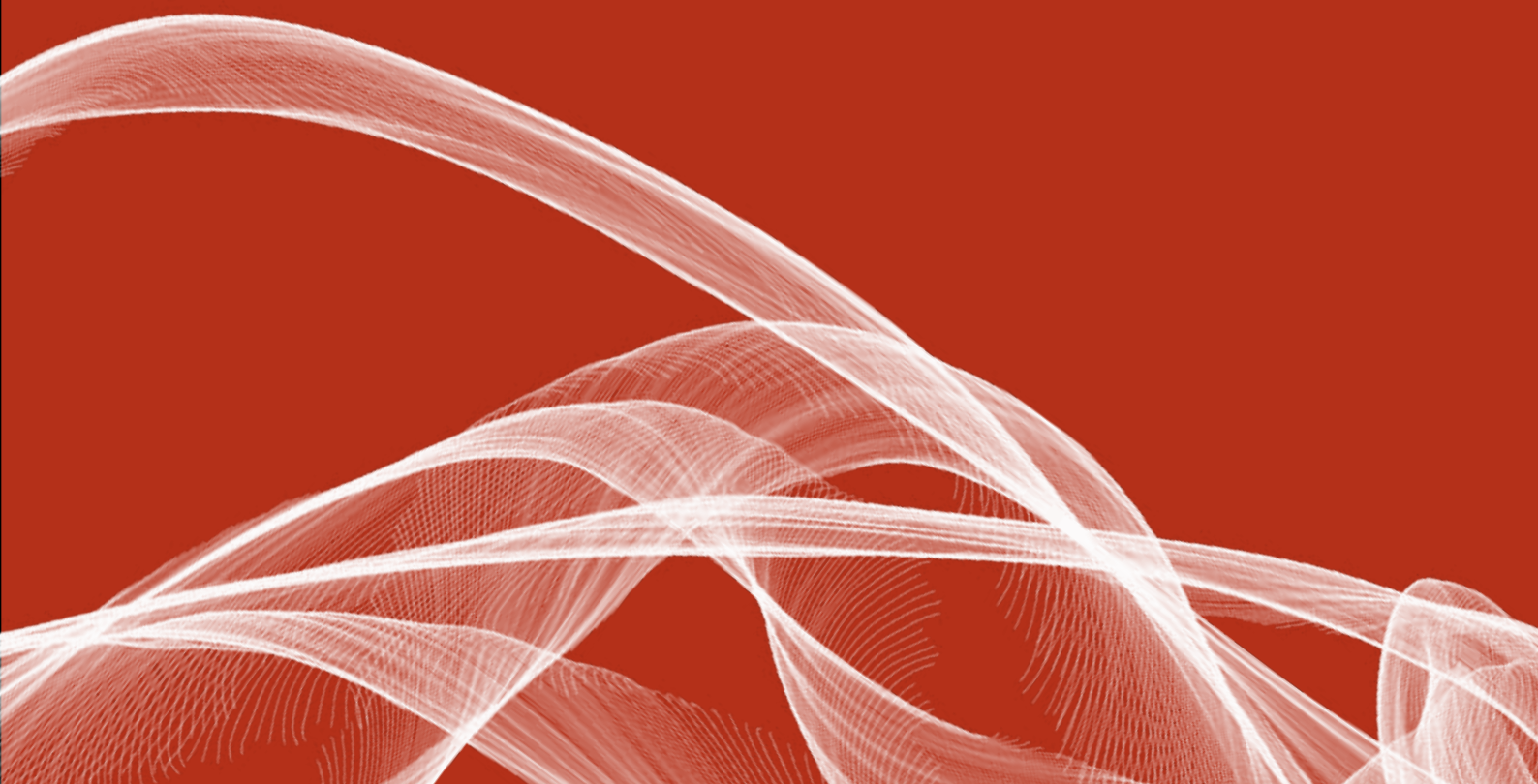



Miller Insurance, 70, Mark Lane, City of London
Consulting Engineer: Hurley Palmer Flatt
Architect: Bennetts Associates

The major insurance broker, Millar Insurance, occupies 85,000 sq ft of this recently completed 16 storey building with stepped profile and dramatic winter garden. Enclosed by an eclectic array of office buildings, including Fenchurch Street Station's forecourt, and the conservation area containing St Olave's Church (the burial place of Samuel Pepys) the site constraints were challenging.

To fulfill the lighting requirements of the open plan office areas for both projects the Atelier low glare office luminaire with central microprism lens was supplied. Recessed Lightline LED 60, Bordo LED 150 and TEMPO X161 were also installed.

LIGHT PLANNING, REGULATIONS AND THE BUILT ENVIRONMENT

OFFICE LIGHTING DESIGN

SLL LG7 and BCO Guidelines

There are many aspects to consider when designing and specifying office lighting. It is not only the amount of illuminance needed for the occupants to see the task clearly and move round the building safely that is important, but also the visual comfort of the occupants and the lit appearance of the space. Whether a designer is preparing a layout for a speculative project with an unknown end user or for a known client, the lighting design for both are equally important. Decisions on luminaire and lamp type and light distribution have to be made. Whether direct lighting, indirect lighting or a combination of direct and indirect is feasible or desirable? Whether localised lighting or task lighting should be considered? What type of control system is appropriate? Each option will have advantages and disadvantages.

The Society of Light and Lighting (SLL/CIBSE) has various documents that can help with best practice design. Lighting Guide 7 addresses all issues of electrical lighting and day lighting for offices. It contains information on the current illuminance level and glare rating for each task or area, but also advice on the lit appearance. Every area is considered; its use and size, general offices, large and small, board rooms, corridors and rest rooms, reception areas and the post room. The lit environment has an impact on energy use, therefore information is also given on the use of control systems. There is also The British Council for Offices Guide to Lighting: Best Practice in the lighting of offices which is both useful and informative for all types of office. It to addresses daylight and energy use, visual comfort and performance. The differences between Shell and Core, Category A and Category B artificial lighting are explained.

BS EN12464

It is undisputed that the appropriate amount of light and type of light enables people to perform visual tasks efficiently and accurately. BS EN12464-1 is the most recent version of the standard for indoor work places. It stipulates the requirements for lighting of most indoor work places and associated areas, addressing both quantity and quality of illumination, together with recommendations for good lighting practice. It aims to encourage designing with all light sources, including natural light, recognising the importance of daylight for energy saving. It includes the requirement for ceiling and wall illuminance to increase the actual and perceived brightness of a room.

PART L BUILDING REGULATIONS

Under the Climate Change Act 2008, the UK has committed to legally binding, greenhouse gas emissions reduction targets by 2020 - at least 26% relative to 1990. Therefore, what must be adhered to is the UK Government's Building Regulations on energy efficiency known as Part L (2014), with Part L2 being specific to 'non dwellings'. The latest requirements entail the use of LENI (the Lighting Efficiency Numeric Indicator). This method measures (and can be used to calculate) the efficiency of the whole lighting installation, not just the components; lighting controls have a key role in this.

THE BUILT ENVIRONMENT

As a team, the lighting designer, architect and all others in the design process, together with the developer or owner may consider designing their building to meet a BREEAM (Building Research Establishment Environmental Assessment Methodology) rating. The BREEAM criteria covers a range of issues in categories that evaluate all aspects of a building's performance, not just energy use. One category is health and well being of which lighting is one aspect. The overall purpose and impact of BREEAM is its drive to greater awareness in sustainability and innovation in the built environment.

FINANCIAL CREDITS

ECA (Enhanced Capital Allowance) scheme is a UK Government programme to help manage climate change by providing business with enhanced tax relief for investments in equipment that meet its energy saving standards. This applies not just to luminaires and light sources but to all electrical equipment that meet the strict criteria.

ATELIER FRAME

The new generation

An innovative office lighting solution

High performance

Visual comfort

Style



ATELIER FRAME

SQUARE

ATELIER FRAME is an LED recessed luminaire developed for the office environment, offering the best lighting quality and meeting the lighting needs for every type of office workplace.

Visual comfort and luminaire performance are the key qualities of ATELIER FRAME. The unique aspect of the luminaire is the combination of high performance optical materials working together for optimum light output and visual comfort.

The central light-control panel is constructed in a choice of optics offering different light distributions and efficiencies, the choice depending on the workplace specification.

Visual comfort, paramount to good lighting, is achieved by framing the central area of the luminaire with a highly tooled optical surround with advanced-technology diffusing properties. This frame provides controlled contrast between the central section, which delivers the major part of the illumination, and the surrounding ceiling. This subtle modulation of light obviates any harsh changes from light to dark across the ceiling.

The optical technology and graded illumination of the ATELIER FRAME has the British Patent pending, number 1502210.6





ATELIER FRAME MICROPRISM OR SATIN OPAL

DESIGN FEATURES

Modular LED recessed luminaire for DSE workstations. Designed to be supported from a variety of ceiling systems, typically exposed T ceilings (15mm & 24mm) and designer grid ceilings (15/08 & 15/16 versions) are available on request. Other ceiling systems can be catered for. Thermally designed for the best possible LED operating conditions, ensuring product longevity. Lumen Maintenance figures of 70% (L70) or higher after 50,000 hours of use. CRI Ra > 80 - 3 MacAdam ellipses. Available in 3000K or 4000K colour temperatures. Symmetrical, evenly spaced LEDs. Diffusers: Specialised blend, engineered PMMA* construction (* Polymethyl methacrylate) combined with microprism or satin opal light-control panels. Glare control: UGR from < 19 to < 20. Glare free light distribution < 1500/3000cds/m². Luminaire luminous flux to 136lms/W. Integral plug and socket connector. Painted steel body construction. Emergency versions are available. All light Engine/Driver protocols are available.



CEILINGINGS

Suspended ceiling systems vary and the installation method is to suit the ceiling type. Please specify the ceiling manufacture and ceiling model. E.g. SAS 130.

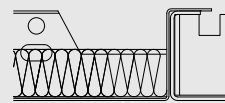

WITHOUT GASKET

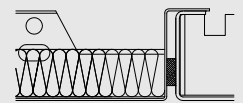

WITH GASKET

AIR HANDLING

Air Handling luminaires are often specified as part of an office heating, ventilating and air-conditioning (HVAC) system. Air-handling vent holes or slots can be incorporated in the luminaire design to allow air to pass through. However, HVAC specifications vary, please contact us for more information.

Typical lay-in exposed tee.

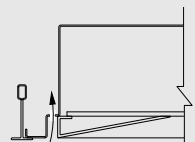

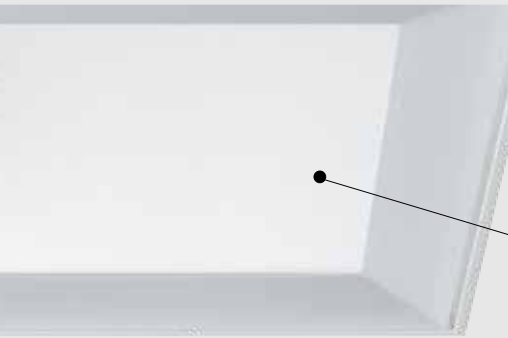

MICROPRISM

The cast microprism central panel diffuser combined with a graduated PMMA* surround is an effective high efficiency, low glare lighting solution UGR < 19

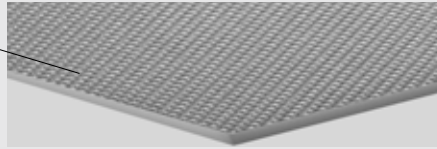

SATIN OPAL

The special diffusing properties of the satin opal central panel diffuser combined with a graduated PMMA* surround offers a clean, even lighting quality - high transmission with even diffusion. UGR < 20

The central light-control panel is constructed in a choice of optics offering slightly different light distributions, the choice depending on the on the workplace specification.

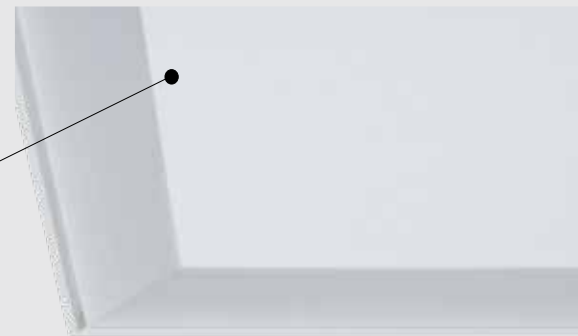

ATELIER FRAME's slim trim detail ensures a neatly detailed aesthetic for a variety of modular ceilings



Painted steel body construction. The one piece luminaire is designed for lift and tilt installation for many different ceiling types.



Simple integral plug and socket connector: No need to open the luminaire or use tools.



Symmetrical, evenly spaced LEDs ensure even luminaire brightness.

ATELIER FRAME

MICROPRISM 600 X 600 GRID

ATELIER FRAME Low glare, recessed office luminaire with central cast microprism panel, opal frame and white ceiling trim (RAL 9010). Overall dimension 595 x 595mm. Complete with standard operation driver.

Dimmable drivers are available to specification: 1-10v, DSI, Dali, Leading/trailing edge or addressable. Please contact us for the correct specification.
 Luminous flux quoted per 380 x 380mm board. @ tp = 65°C
 Colour rendering: CRI (Ra) >80
 Lumen Maintenance figures of 70% (L70) or higher after 50,000 hours of use.

Product No	Colour Temp (Kelvin)	Typical Output (Lms)	LED Load W	mA	IP
M0110	3000K	4,800	39.5	1050	IP20
M0210	4000K	5,470	39.5	1050	IP20

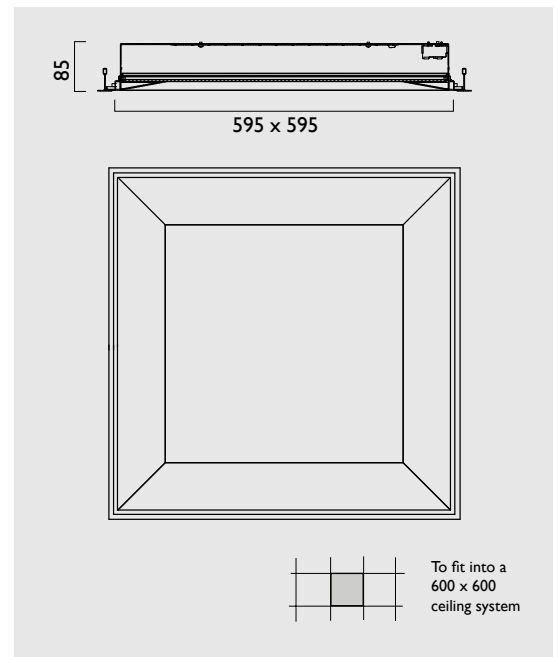

Glare Control
 UGR < 19
 < 1500/3000 cds/m²

Light Output Ratio
 ULOR 0%
 DLOR 76%

Intensity values in cds per 1,000 lumens.

Type M0210 - 4000K - 5,470lms

Spacing: 2.4m x 2.4m
 Maintenance: 0.8
 Reflectance: 70 / 50 / 20
 Ceiling Height: 2.8m
 Working Plane: 0.8m

Illuminance	Uniformity	UGR
589lux	0.88	17.2

Total Lumens can be varied by tuning the driver's forward current (mA), therefore increasing or decreasing the illuminance.

Type M0210 - 4000K - 5,470lms

Spacing: 3m x 3m
 Maintenance: 0.8
 Reflectance: 70 / 50 / 20
 Ceiling Height: 2.8m
 Working Plane: 0.8m

Illuminance	Uniformity	UGR
412lux	0.72	17.7

Total Lumens can be varied by tuning the driver's forward current (mA), therefore increasing or decreasing the illuminance.

EN 60598-1
 WEE/AE0290TY

ISO 9001 REGISTERED FIRM
 ISO 14001 REGISTERED FIRM

ATELIER FRAME

SATIN OPAL 600 X 600 GRID

ATELIER FRAME Low glare, recessed office luminaire with central lens panel, opal frame and white ceiling trim (RAL 9010).

Overall dimension 595 x 595mm. Complete with standard operation driver.

Dimmable drivers are available to specification: 1-10v, DSI, DALI, Leading/trailing edge or addressable. Please contact us for the correct specification.

Luminous flux quoted per 380 x 380mm board. @ tp = 65°C

Colour rendering: CRI (Ra) >80

Lumen Maintenance figures of 70% (L70) or higher after 50,000 hours of use.

Product No	Colour Temp (Kelvin)	Typical Output (Lms)	LED Load W	mA	IP
M0310	3000K	4,800	39.5	1050	IP20
M0410	4000K	5,470	39.5	1050	IP20

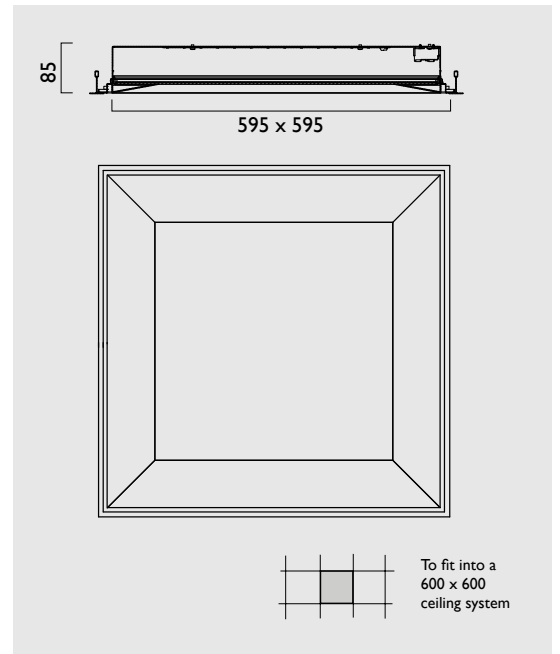

Glare Control
UGR < 20
< 1500/3000 cds/m²

Light Output Ratio
ULOR 0%
DLOR 80%

Intensity values in cds per 1,000 lumens.

Type M0410 - 4000K - 5,470lms

Spacing: 3m x 3m
Maintenance: 0.8
Reflectance: 70 / 50 / 20
Ceiling Height: 2.8m
Working Plane: 0.8m

Illuminance 405lux Uniformity 0.84 UGR 20

Total Lumens can be varied by tuning the driver's forward current (mA), therefore increasing or decreasing the illuminance.

Type M0410 - 4000K - 5,470lms

Spacing: 3.6m ctrs
Maintenance: 0.8
Reflectance: 70 / 50 / 20
Ceiling Height: 2.8m
Working Plane: 0m

Illuminance 243lux

Total Lumens can be varied by tuning the driver's forward current (mA), therefore increasing or decreasing the illuminance.

EN 60598-1
WEE/AE0290TY



ATELIER FRAME

The new generation

An innovative office lighting solution

High performance

Visual comfort

Style

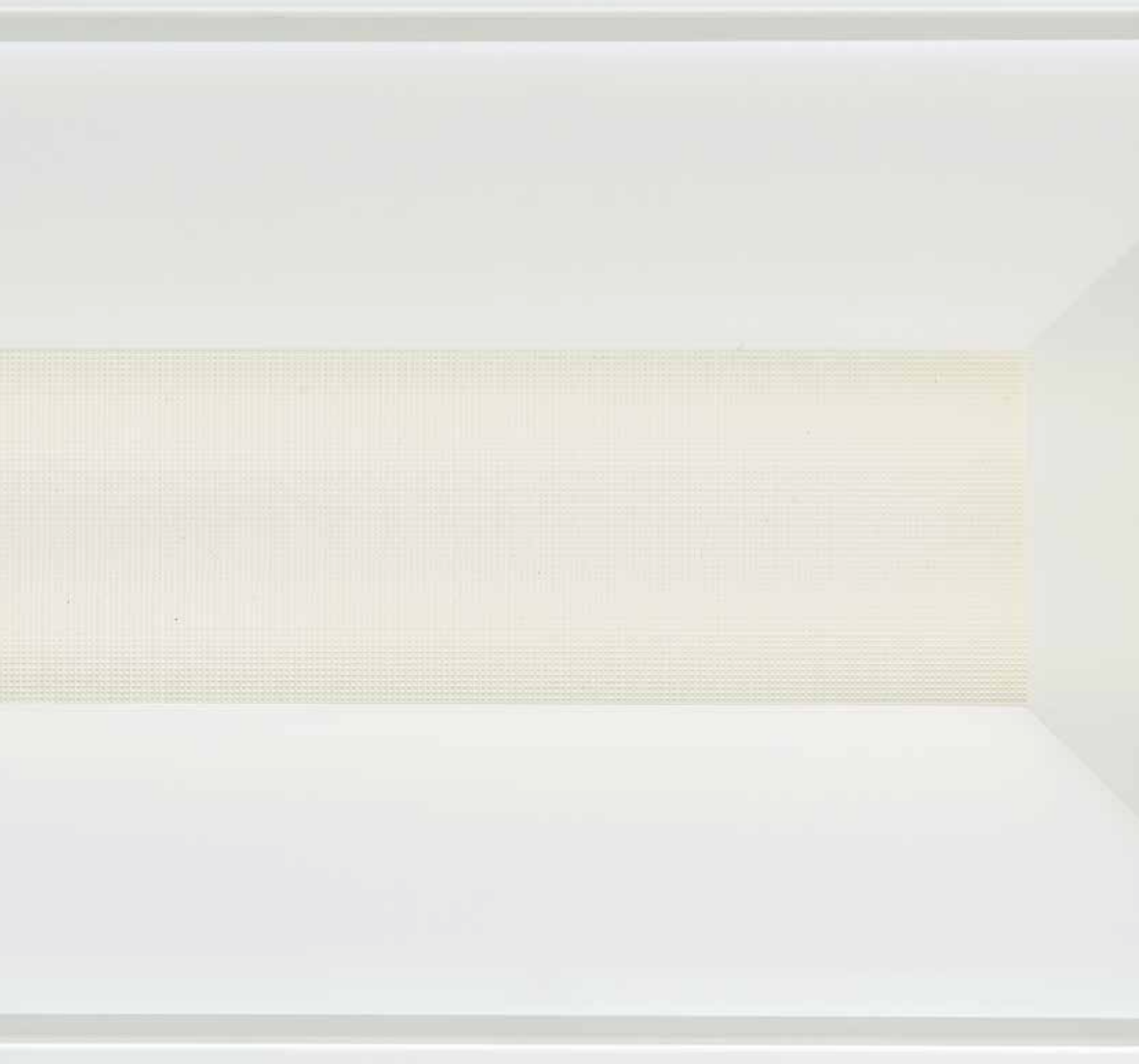

ATELIER FRAME

LINEAR

ATELIER FRAME is an LED recessed luminaire developed for the office environment, offering the best lighting quality and meeting the lighting needs for every type of office workplace.

Visual comfort and luminaire performance are the key qualities of ATELIER FRAME. The unique aspect of the luminaire is the combination of high performance optical materials working together for optimum light output and visual comfort.

The central light-control panel is constructed in a choice of optics offering different light distributions and efficiencies, the choice depending on the workplace specification.

Visual comfort, paramount to good lighting, is achieved by framing the central area of the luminaire with a highly tooled optical surround with advanced-technology diffusing properties. This frame provides controlled contrast between the central section, which delivers the major part of the illumination, and the surrounding ceiling. This subtle modulation of light obviates any harsh changes from light to dark across the ceiling.

The optical technology and graded illumination of the ATELIER FRAME has the British Patent pending, number 1502210.6





ATELIER FRAME MICROPRISM OR SATIN OPAL

DESIGN FEATURES

Modular LED recessed luminaire for DSE workstations. Designed to be supported from a variety of ceiling systems, typically exposed T ceilings (15mm & 24mm) and designer grid ceilings (15/08 & 15/16 versions) are available on request. Other ceiling systems can be catered for.

Thermally designed for the best possible LED operating conditions, ensuring product longevity.

Lumen Maintenance figures of 70% (L70) or higher after 50,000 hours of use.

CRI Ra > 80 - 3 MacAdam ellipses.

Available in 3000K or 4000K colour temperatures.

Symmetrical, evenly spaced LEDs.

Diffusers: Specialised blend, engineered PMMA* construction (* Polymethyl methacrylate) combined microprism or satin opal light-control panels.

Glare control: UGR from < 19 to < 20.

Glare free light distribution < 1500/3000cds/m².

Luminaire luminous flux to 136lm/W.

Integral plug and socket connector.

Painted steel body construction.

Emergency versions are available.

All light Engine/Driver protocols are available.



CEILINGINGS

Suspended ceiling systems vary and the installation method is to suit the ceiling type. Please specify the ceiling manufacture and ceiling model. For example: SAS 330.

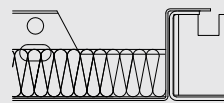

WITHOUT GASKET

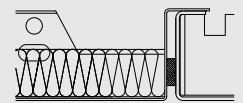

WITH GASKET

AIR HANDLING

Air Handling luminaires are often specified as part of an office heating, ventilating and air-conditioning (HVAC) system. Air-handling vent holes or slots can be incorporated in the luminaire design to allow air to pass through. However, HVAC specifications vary, please contact us for more information.

Typical lay-in exposed tee

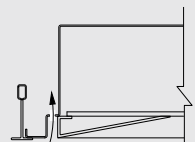

MICROPRISM

The cast microprism central panel diffuser combined with a graduated PMMA* surround is an effective high efficiency, low glare lighting solution UGR < 19

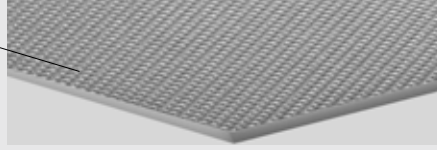
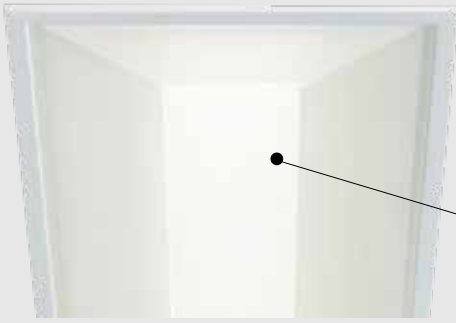

SATIN OPAL

The special diffusing properties of the satin opal central panel diffuser combined with a graduated PMMA* surround offers a clean, even lighting quality - high transmission with even diffusion. UGR < 20

The central light-control panel is constructed in a choice of optics offering slightly different light distributions, the choice depending on the on the workplace specification.

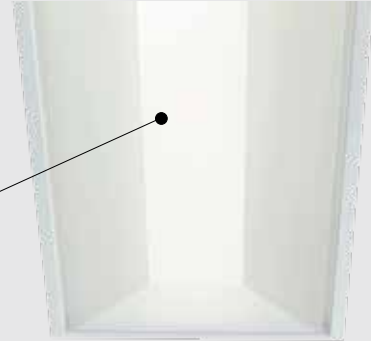

ATELIER FRAME's slim trim detail ensures a neatly detailed aesthetic for a variety of modular ceilings



Painted steel body construction. The one piece luminaire is designed for lift and tilt installation for many different ceiling types.



Simple integral plug and socket connector. No need to open the luminaire or use tools.



Linear evenly spaced LED's ensures even luminaire brightness.

ATELIER FRAME

MICROPRISM | 200 x 300 GRID

ATELIER FRAME Low glare, recessed office luminaire with central cast microprism panel and opal frame, and white ceiling trim (RAL 9010).

Overall dimension 1195 x 295mm. Complete with standard operation driver.

Dimmable drivers are available to specification: I-10v, DSI, DALI, Leading/trailing edge or addressable. Please contact us for the correct specification.

Luminous flux quoted per 559mm board. @ tp = 65°C

Colour rendering: CRI (Ra) >80

Lumen Maintenance figures of 70% (L70) or higher after 50,000 hours of use.

Product No	Colour Temp (Kelvin)	Typical Output (Lms)	LED Load (W)	mA	IP
M1112	3000K	5760	42	300	IP20
M1212	4000K	5960	42	300	IP20

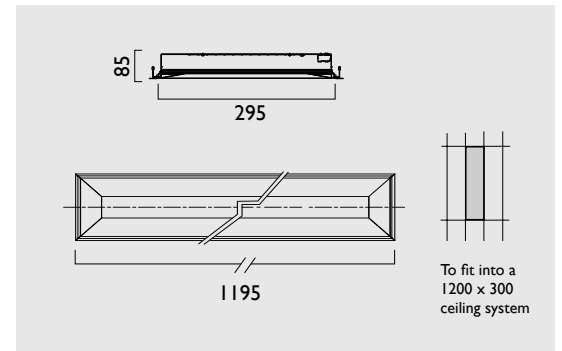

ATELIER FRAME

SATIN OPAL | 200 x 300

ATELIER FRAME LED Low glare, recessed office luminaire with central satin opal panel and opal frame, and white ceiling trim (RAL 9010).

Overall dimension 1195 x 295mm. Complete with standard operation driver.

Dimmable drivers are available to specification: I-10v, DSI, DALI, Leading/trailing edge or addressable. Please contact us for the correct specification.

Luminous flux quoted per 559mm board. @ tp = 65°C

Colour rendering: CRI (Ra) >80

Lumen Maintenance figures of 70% (L70) or higher after 50,000 hours of use.

Product No	Colour Temp (Kelvin)	Typical Output (Lumens)	LED Load W	mA	IP
M1512	3000K	5760	42	300	IP20
M1612	4000K	5960	42	300	IP20

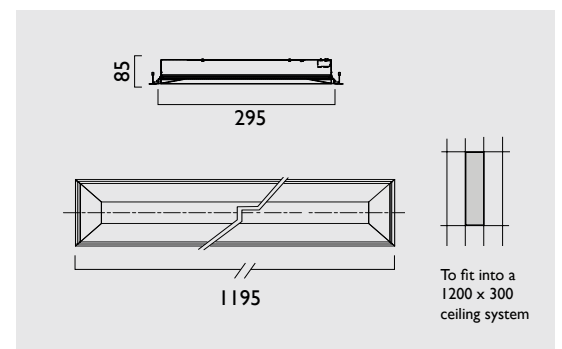

ATELIER FRAME

CUSTOM

Alongside the standard range of luminaires DAL has extensive experience in the design and manufacture of custom luminaires. There are many different ceiling manufacturers with many suspended ceiling systems to choose from.

The ATELIER FRAME, low glare, high performance recessed office luminaire can be designed to integrate with most suspended ceiling systems. ATELIER FRAME can also be detailed to suit plaster ceilings. The growing variety of LED board dimensions make unique lengths a possibility. For example, 1500 x 300 modules.

With over 30 years of experience of designing many custom products the most exacting of projects can be achieved.





ATELIER PLUS

LINEAR MODULE

ATELIER LED modular luminaires are the ideal product for general office lighting. Practical and functional, it offers a low brightness, high efficacy, cost effective solution to today's exacting lighting requirements and energy use limits.

The ATELIER LED luminaire is designed with sharp edge detail for a clean ceiling look. The shallow construction and precise optic configuration ensures optimum lighting performance. Atelier LED is an ideal luminaire for open plan or cellular offices.

ATELIER LED uses the highest quality nanoprism lens, maximising the LED light transmission. The central element has a unique side liner prism which produces the best possible distribution.

The recessed frosted diffuser panel provides a large luminous area both diffusing and inter reflecting the light, resulting in a large luminous area of low brightness which gives a pleasing appearance, making the space feel spacious by avoiding a cave like feel.



ATELIER PLUS

SQUARE MODULE



Design Features

With visual comfort and luminaire efficiency at the forefront all luminaires have the following features:

- Nanoprism and linear prismatic optic technology.
- Frosted recessed panel to provide a large luminous area
- Shallow recess depth
- Robust steel construction
- Finished high quality low gloss powder coat finish - RAL 9010
- Easy installation



LED Features:

- High colour rendering index CRI >Ra80 as standard
- Small colour tolerance 3 step MacAdam
- Small luminous flux tolerances
- Colour consistency
- Colour temperature 3000K / 4000K
- Perfectly uniform light, even if several LED modules are used in a line.
- CRI >Ra90 is also available.

ATELIER PLUS

600 x 600 GRID

ATELIER PLUS LED 600x 600 low glare, recessed office luminaire with central nanoprism lens, lit diffuser and white ceiling trim (RAL 9010).

Overall dimension 595 x 595mm. Complete with standard operation driver.

Dimmable drivers are available to specification: 1-10v, DSI, DALI, Leading/trailing edge or addressable. Please contact us for the correct specification.



Product No	Typical Dimension (mm)	Colour Temp (Kelvin)	Typical Output (Lms)	LED Load (W)
High Output - 375mA				
L5000	600 x 600	3000K	3560	30.4
L5100	600 x 600	4000K	3860	30.4

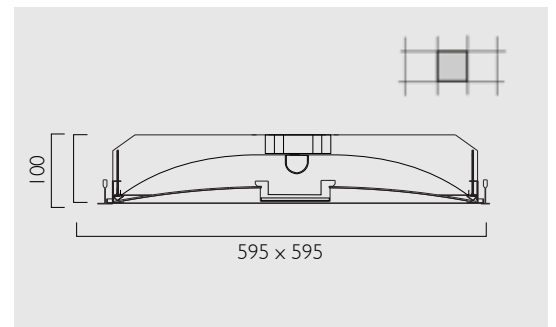

ATELIER PANEL

600 x 600 GRID

ATELIER PANEL Low glare, recessed office luminaire with microprism diffuser and white ceiling trim (RAL 9010).

Overall dimension 595 x 595mm. Complete with standard operation driver.

Dimmable drivers are available to specification: 1-10v, DSI, DALI, Leading/trailing edge or addressable. Please contact us for the correct specification.



Product No	Typical Dimension (mm)	Colour Temp (Kelvin)	Typical Output (Lumens)	LED Load (Wattage)
M3010	595 x 595	3000K	4900	32
M3110	595 x 595	4000K	5000	32
M3210	595 x 595	3000K	5800	38
M3310	595 x 595	4000K	6000	38

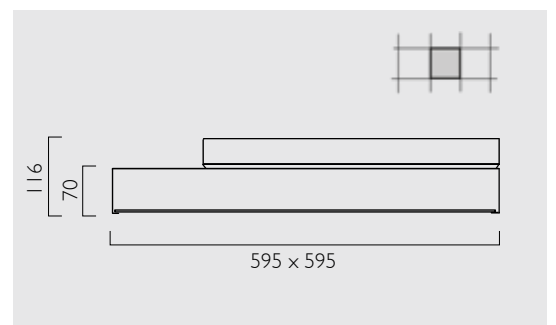

Please contact us for further luminaire sizes e.g. 1200 x 300 and 1500 x 300.

Air Handling luminaires are often specified as part of an office heating, ventilating and air-conditioning (HVAC) system. Air handling vent holes or slots can be incorporated in the luminaire design to allow air to pass through. However, HVAC specifications vary, so please contact us for more information.

Suspended ceiling systems vary. Please specify the ceiling manufacture and ceiling model.



ATELIER PLUS

RECTANGULAR



ATELIER LED modular luminaires are the ideal product for general office lighting. Practical and functional, it offers a low brightness, high efficacy, cost effective solution to today's exacting lighting requirements and energy use limits.

The ATELIER LED luminaire is designed with sharp edge detail for a clean ceiling look. The shallow construction and precise optic configuration ensures optimum lighting performance. Atelier LED is an ideal luminaire for open plan or cellular offices. ATELIER LED uses the highest quality nanoprism lens, maximising the LED light transmission. The central element has a unique side liner prism which produces the best possible distribution.

The recessed frosted diffuser panel provides a large luminous area both diffusing and inter-reflecting the light, resulting in a large luminous area of low brightness which gives a pleasing appearance, making the space feel spacious by avoiding a cave like feel.

With visual comfort and luminaire efficiency at the forefront all luminaires have the following features:

- Nanoprism and linear prismatic optic technology.
- Frosted recessed panel to provide a large luminous area
- Shallow recess depth
- Robust steel construction
- Finished high quality low gloss powder coat finish - RAL 9010
- Easy installation



LED Features:

- High colour rendering index CRI >Ra80
- Small colour tolerance 3 step MacAdam
- Small luminous flux tolerances
- Colour consistency
- Colour temperature 3000K / 4000K
- Perfectly uniform light, even if several LED modules are used in a line.
- CRI >Ra90 is also available.



Typical Air Handling slot detail.

ATELIER PLUS

1200 x 300 GRID

ATELIER LED 1200 x 300 low glare, recessed office luminaire with central nanoprism lens, lit diffuser and white ceiling trim (RAL 9010).

Overall dimension 1200 x 300mm. Complete with standard operation driver.

Dimmable drivers are available to specification: I-10v, DSI, DALI, Leading/trailing edge or addressable. Please contact us for the correct specification.

The installation method is to suit the ceiling type. Please specify the ceiling manufacture and ceiling model.

Product No	Typical Dimension (mm)	Colour Temp (Kelvin)	Typical Output (Lms)	LED Load (W)
High Output LED - 250mA				
L6200	1200 x 300	3000K	4520	31.2
L6300	1200 x 300	4000K	4680	31.2
High Output LED - 300mA				
L6201	1200 x 300	3000K	5280	38.4
L6301	1200 x 300	4000K	5440	38.4

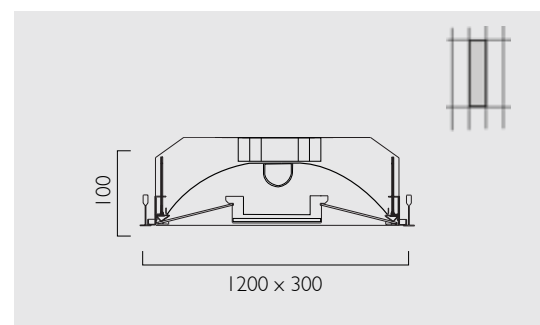

ATELIER PLUS

1500 x 300 GRID

ATELIER LED 1500 x 300 low glare, recessed office luminaire with central nanoprism lens, lit diffuser and white ceiling trim (RAL 9010). Overall dimension 1500 x 300mm

Complete with standard operation driver.

Dimmable drivers are available to specification: I-10v, DSI, DALI, Leading/trailing edge.

Product No	Typical Dimension (mm)	Colour Temp (Kelvin)	Typical Output (Lms)	LED Load (W)
Mid Output LED - 350mA				
L7000	1500 x 300	3000K	4100	31
L7100	1500 x 300	4000K	4200	31
High Output LED - 250mA				
L7001	1500 x 300	3000K	5650	39
L7101	1500 x 300	4000K	5850	39
High Output LED - 300mA				
L7002	1500 x 300	3000K	6600	48
L7102	1500 x 300	4000K	6800	48

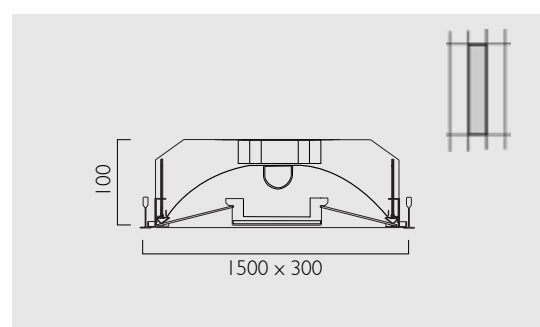

Air Handling luminaires are often specified as part of an office heating, ventilating and air-conditioning (HVAC) system. Air handling vent holes or slots can be incorporated in the luminaire design to allow air to pass through. However, HVAC specifications vary, so please contact us for more information.

Suspended ceiling systems vary. Please specify the ceiling manufacture and ceiling model.



ONETWENTY Holborn
Consulting Engineer: Cundall
Architects: John Robertson Architects
Electrical Contractor: CCE Projects Ltd

This John Seifert building on Holborn Circus was designed and built in the late 1970s. In 2015 the building was refurbished for Wainbridge Global, the real estate investment company. The company's aim is to rejuvenate out of date office buildings, particularly within the London Metropolitan Area.

As part of this high end specification DAL developed a special 65mm high LIGHTLINE 60 with remote driver for installing in plasterboard and skim ceilings.

LINEAR SYSTEMS

DAL's range of linear products has luminaires to suit many applications, from conventional area lighting to accent and architectural lighting. The LIGHTLINE range of luminaires are designed to create neat lines of light on or within the ceiling and are available in surface mounted, suspended or recessed versions. BORDO is a bespoke product, usually developed as a complete system, accommodating integral sound, smoke detection, emergency and controls. Architectural lighting products like WALLWASHER, COVELINE, GRAZER and PROJECTOR are usually integrated with the building detail to create specific lighting effects.

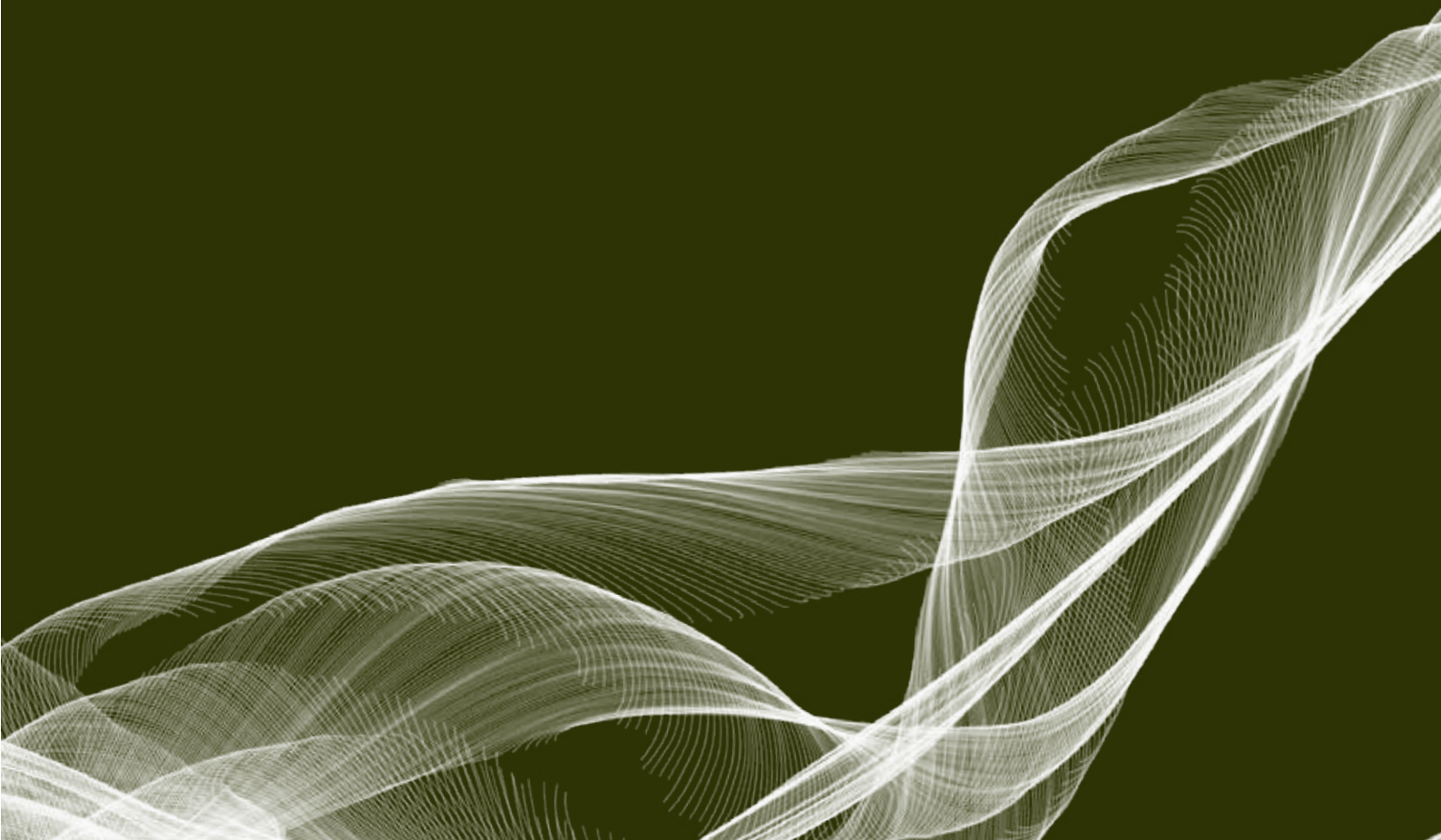

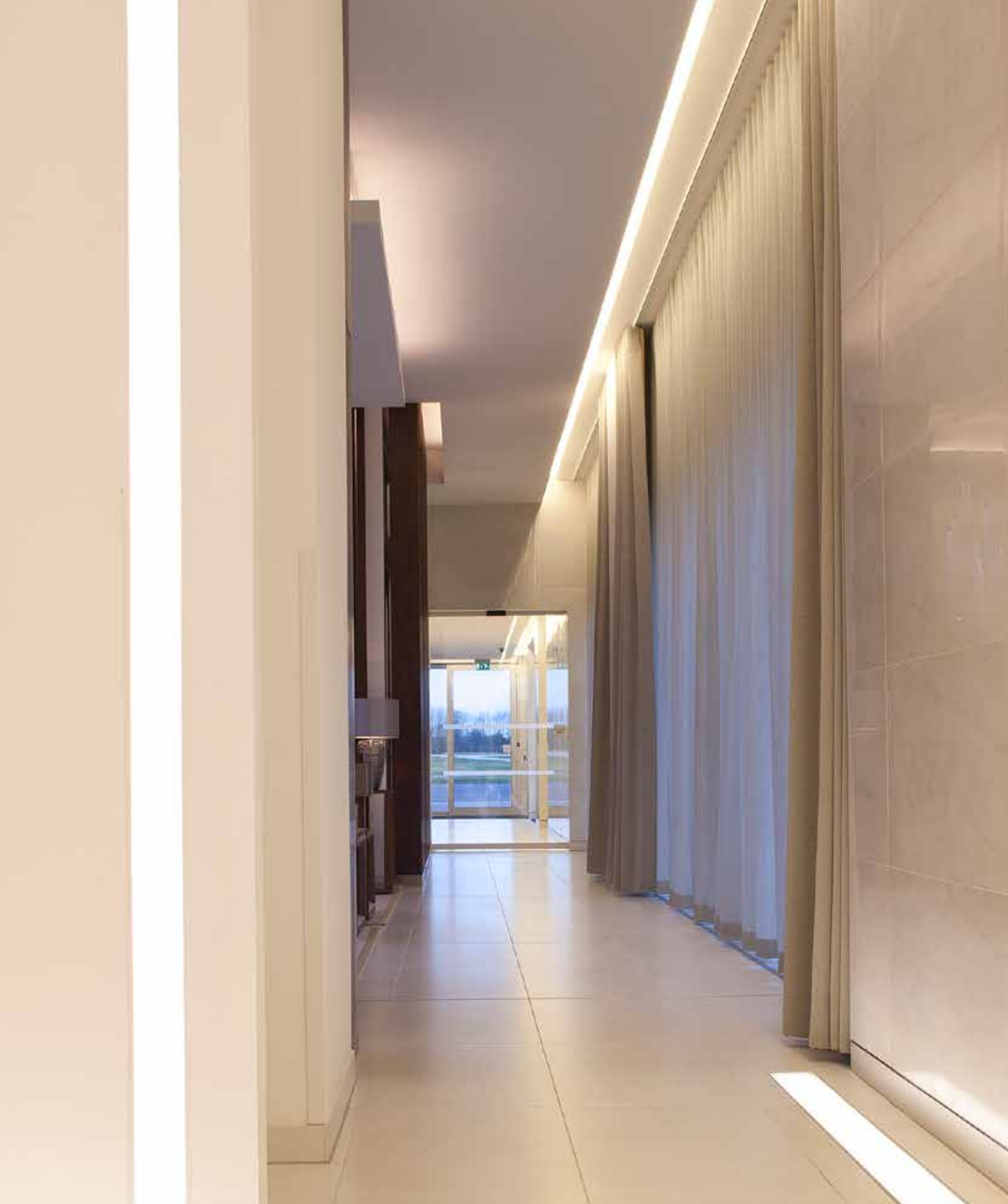

Private Airline Lounges, Stansted Airport
Lighting Consultant: Paul Nulty, PNLD
Photographer: © Sanna Fisher-Payne

The architectural aesthetic of this exclusive airline facility is strengthened by the use of a bespoke concealed cove lighting and DAL's TERRA LED 150 recessed floor system, which enhances the rich dark wood and emphasises the clean lines and long expanses of warm marble; materials that are complimented by the LEDs specially chosen for the project.

THE LIT SCENE AND LIGHTING TECHNIQUES

When lighting a space the whole scene should be considered, we should not rely on just one method of lighting. For example, an office space that requires uniform illuminance on the working plane should also have variation in the visual field. Adding luminance (brightness) to the walls in the field of view aids visual comfort. Details on what levels are advisable are explained in books and documents, and in particular the CIBSE/SLL Lighting Guide 7 and also The British Council for Offices Guide to Lighting: Best Practice in the lighting of offices.

When creating a lit scene, whether enhancing particular surfaces by preferentially lighting the ceiling or walls, there are several techniques at the designers' disposal. The ratio of bright to shade can be used to draw the eye, causing the viewer and user of the space to rest or travel through. These concepts, together with the room surface colours and textures, can also affect the perceived size and shape of a space and can also add interest and atmosphere. There are several techniques that can be used effectively.

All preferentially lit surfaces will add reflected light to a space; the amount of light will depend on the reflectance of the surface finish. It has to be noted, if the finish is shiny it may reflect images of the light source. Aesthetically, a designer can choose from linear luminaires or square or circular aperture fittings. In each case the relationship between the light source and the surface being lit is important, adequate room and distances are needed to enable an effective spread of light.



EDGE LIGHTING

Edge or slot lighting is an effect which will create a bright upper part to a wall. The technique can be used to light the space indirectly. The ceiling will usually appear dark against the brightness of the wall, outlining its shape. However, it is hard to light a surface evenly with a close off-set luminaire.

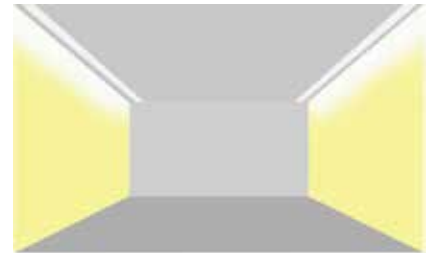

GRAZING

Grazing is a technique used to reveal and enhance the texture of a surface. Like edge lighting, it is hard to light the surface evenly from top to bottom, but a lens optic will help to throw the light further.



COVE LIGHTING

Cove lighting is a method of uplighting or indirect lighting. The cove can be around the edge of a space, in a drop ceiling or forming recesses in a suspended ceiling. The size of the cove affects the spread of light and care has to be taken to shield the lamp from view.



WALLWASHING

The intent of wall washing is to light the wall as evenly as possible. It tends to hide imperfections but also visually flattens the surface. To achieve an evenly lit effect it is important to get the correct off-set from the wall and distance apart.

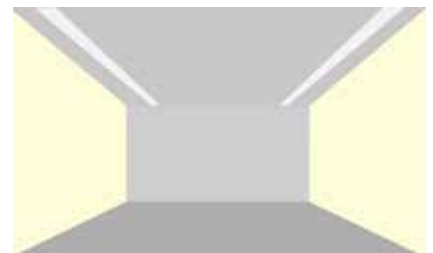

LIGHTLINE LED 60 / 88

LIGHTLINE is an elegant linear luminaire designed to create neat lines of light on or within the ceiling. It is available in surface mounted, suspended, recessed or trimless versions. It can be supplied as individual modules or modules to create continuous runs. Complete with integral or remote drivers.

LIGHTLINE is an adaptable product. As outlined it is able to be surface mounted, suspended or recessed and able to answer all the needs of a single project.

Designed Architectural Lighting is a flexible, customer friendly company and LIGHTLINE can be supplied in different colour finishes if required.

LIGHTLINE LED 60 / 88 luminaires have the following features:

- Robust extruded aluminium construction
- Sharp edge detail
- Easily installed components
- Satin opal diffuser. Microprism lens diffuser is also available.
- Integral reflector
- 60mm or 80mm lit width
- Surface and pendant versions finished metallic silver
- Recessed version ceiling trim finished white RAL 9010
- Drivers are integral or remote mounted, depending on the Lightline profile
- Driver options are: non-dimmable or dimmable protocols: 1-10v, DSI, DALI, Lead/trailing edge.

LED Features:

- High colour rendering index CRI (Ra) >80
- Small colour tolerance
- Small luminous flux tolerances
- Good colour consistency
- Colour temperature 3000K / 4000K
- Perfectly uniform light, even if several LED modules are used in a line.

SURFACE / PENDANT

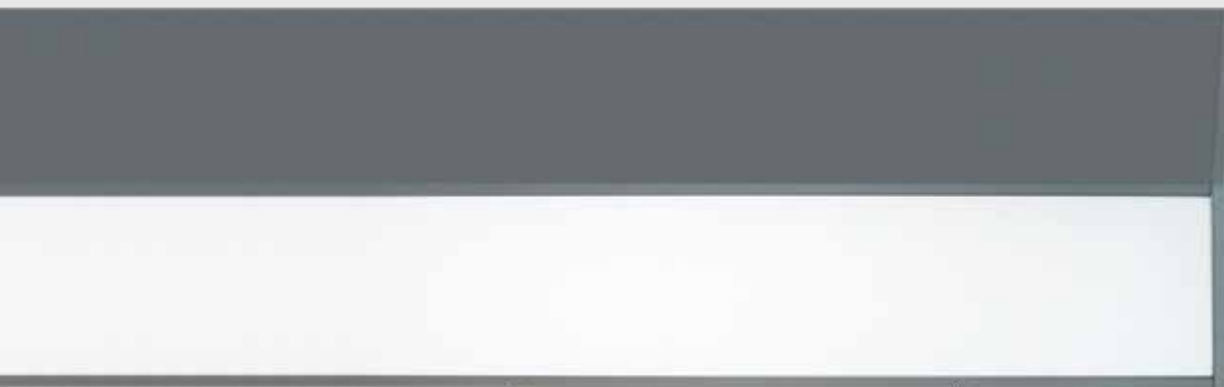



ONETWENTY Holborn
Consulting Engineer: Cundall
M&E Engineers: CCE Projects LTD
Architects: John Robertson Architects

RECESSED TRIM



TRIMLESS

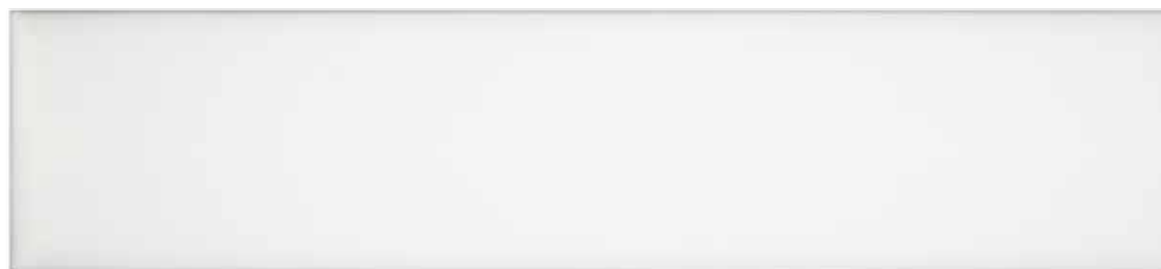

LIGHTLINE LED 60

SURFACE / PENDANT

LIGHTLINE LED 60 Surface or Pendant luminaire. It consists of an aluminium extruded profile constructed as individual modules in various chassis lengths, which come complete with integral or remote driver. Optical control is provided by a clip in opal diffuser. Microprism lens diffuser is also available.

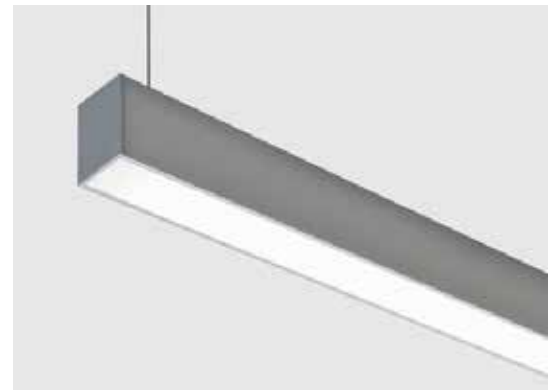

	High Efficiency	High Output
Typical Luminous flux per 280mm board. @ tp = 65°C	620 lumens, 3000K, 640 lumens, 4000K	1130 lumens, 3000K 1170 lumens, 4000K
CRI (Ra)	>80	>80
Lifetime	50,000	50,000
IP rating	IP40	IP40
Finish	White (RAL 9010)	White (RAL 9010)
Cover / Lens	Opal	Opal
Mounting	Surface / Pendant	Surface / Pendant
Driver Options	Fixed, DALI, I-10V, DSI	Fixed, DALI, I-10V, DSI

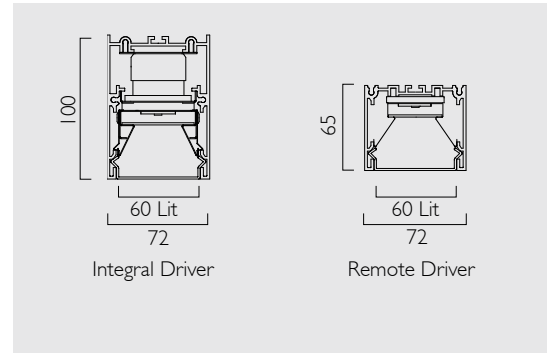

HIGH EFFICIENCY LED

Integral Driver Product No	Remote Driver Product No	No of boards	Length (mm)	Colour Temp (Kelvin)	Typical Output (Lumens)	LED (W)
L1002	L8002	2	580	3000K	1240	8.6
L1003	L8003	3	860	3000K	1860	12.9
L1004	L8004	4	1140	3000K	2480	17.2
L1005	L8005	5	1420	3000K	3100	21.5
L1006	L8006	6	1700	3000K	3720	25.8
L1102	L8102	2	580	4000K	1280	8.6
L1103	L8103	3	860	4000K	1920	12.9
L1104	L8104	4	1140	4000K	2560	17.2
L1105	L8105	5	1420	4000K	3200	21.5
L1106	L8106	6	1700	4000K	3840	25.8

HIGH OUTPUT LED

Integral Driver Product No	Remote Driver Product No	No of boards	Length (mm)	Colour Temp (Kelvin)	Typical Output (Lumens)	LED (W)
L1202	L8202	2	580	3000K	2260	15.6
L1203	L8203	3	860	3000K	3390	23.4
L1204	L8204	4	1140	3000K	4520	31.2
L1205	L8205	5	1420	3000K	5650	39
L1206	L8206	6	1700	3000K	6780	46.8
L1302	L8302	2	580	4000K	2340	15.6
L1303	L8303	3	860	4000K	3510	23.4
L1304	L8304	4	1140	4000K	4680	31.2
L1305	L8305	5	1420	4000K	5850	39
L1306	L8306	6	1700	4000K	7020	46.8

Microprism lens diffuser is also available, please contact us.

LED Features:-

High colour rendering index CRI >Ra80 as standard
 Small colour tolerance 3 Step MacAdam
 Small luminous flux tolerances
 Colour consistency
 Colour temperature 3000K / 4000K
 Perfectly uniform light when LED modules are used in a line.
 CRI >Ra90 is also available.

Continuous Length - High Efficiency
 L1000/L8000 Series - 3000K
 L1100/L8100 Series - 4000K
 Please contact us for further information. As a guide use multiples of 280mm plus 20mm for tolerance and end caps.

Continuous Length - High Output
 L1200/L8200 Series - 3000K
 L1300/L8300 Series - 4000K
 Please contact us for further information. As a guide use multiples of 280mm plus 20mm for tolerance and end caps.



Tunable White LED is available and allows the colour temperature of white light to be set between 3000K - 6000K. To specify add suffix /TW to the driver product number

Please contact us for further information.

LIGHTLINE LED 60

DIRECT / INDIRECT

LIGHTLINE LED 60 DIRECT / INDIRECT Suspended luminaire. It consists of an aluminium extruded profile constructed as individual modules in various chassis lengths, which come complete with integral driver. Direct and Indirect light optical control is provided by a clip in opal diffuser. Microprism lens diffuser is also available.

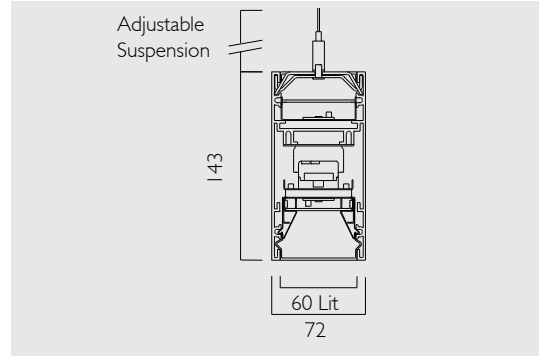
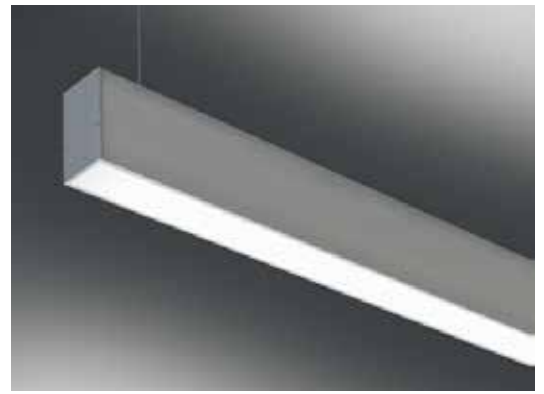

	High Efficiency	High Output
Typical Luminous flux per 280mm board. @ tp = 65°C	620 lumens, 3000K, 640 lumens, 4000K	1130 lumens, 3000K 1170 lumens, 4000K
CRI (Ra)	>80	>80
Lifetime	50,000	50,000
IP rating	IP40	IP40
Finish	Silver grey (RAL 9006)	Silver Grey (RAL9006)
Cover / Lens	Opal	Opal
Mounting	Pendant	Pendant
Driver Options	Fixed, DALI, I-10V, DSI	Fixed, DALI, I-10V, DSI

HIGH EFFICIENCY LED

Integral Driver Product No	No of Boards Down / Up	Length (mm)	Colour Temp (Kelvin)	Typical Output (Lumens)	LED (W)
L3404	4 / 4	1140	3000K	2480 / 2480	17.2 / 17.2
L3405	5 / 5	1430	3000K	3100 / 3100	21.5 / 21.5
L3406	6 / 6	1720	3000K	3720 / 3720	25.8 / 25.8
L3504	4 / 4	1140	4000K	2560 / 2560	17.2 / 17.2
L3505	5 / 5	1430	4000K	3200 / 3200	21.5 / 21.5
L3506	6 / 6	1720	4000K	3840 / 3480	25.8 / 25.8

HIGH OUTPUT LED

Integral Driver Product No	No of Boards Down / Up	Length (mm)	Colour Temp (Kelvin)	Typical Output (Lumens)	LED (W)
L3604	4 / 4	1140	3000K	4520 / 4520	31.2 / 31.2
L3605	5 / 5	1430	3000K	5650 / 5650	39 / 39
L3606	6 / 6	1720	3000K	6780 / 6780	46.8 / 46.8
L3704	4 / 4	1140	4000K	4680 / 4680	31.2 / 31.2
L3705	5 / 5	1430	4000K	5850 / 5850	39 / 39
L3706	6 / 6	1720	4000K	7020 / 7020	46.8 / 46.8

LUMINAIRE DETAIL

Sharp edge aluminium extruded profile and opal diffuser with even flashing along the luminaire. Microprism lens diffuser is also available.

It will be necessary to discuss each project's specific requirements to ensure the correct specification.



LIGHTLINE LED 60

RECESSED WITH TRIM

LIGHTLINE LED 60 Recessed mounting for most ceiling types. It consists of an aluminium extruded profile with ceiling trim. Constructed as individual modules in various chassis lengths, which come complete with integral or remote driver. Optical control is provided by a clip in opal diffuser. Microprism lens diffuser is also available

	High Efficiency	High Output
Typical Luminous flux per 280mm board. @ tp = 65°C	620 lumens, 3000K, 640 lumens, 4000K	1130 lumens, 3000K 1170 lumens, 4000K
CRI (Ra)	>80	>80
Lifetime	50,000	50,000
IP rating	IP40	IP40
Trim Finish	White (RAL 9010)	White (RAL 9010)
Cover / Lens	Opal	Opal
Mounting	Recessed	Recessed
Driver options	Fixed, DALI, I-10V, DSI	Fixed, DALI, I-10V, DSI

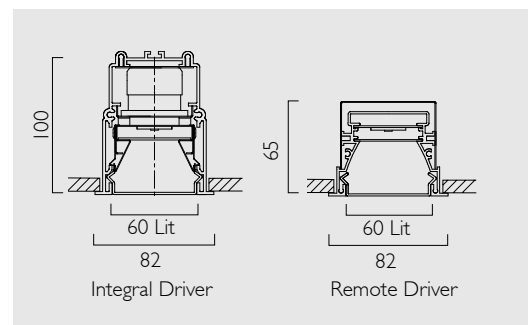
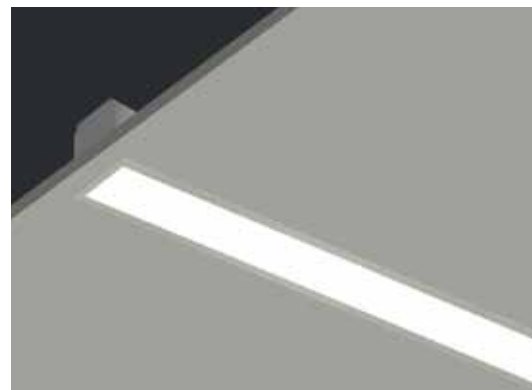

HIGH EFFICIENCY LED

Integral Driver Product No	Remote Driver Product No	No of boards	Length (mm)	Colour Temp (Kelvin)	Typical Output (Lumens)	LED (W)
L1402	L8402	2	590	3000K	1240	8.6
L1403	L8403	3	870	3000K	1860	12.9
L1404	L8404	4	1150	3000K	2480	17.2
L1405	L8405	5	1430	3000K	3100	21.5
L1406	L8406	6	1710	3000K	3720	25.8
L1502	L8502	2	590	4000K	1280	8.6
L1503	L8503	3	870	4000K	1920	12.9
L1504	L8504	4	1150	4000K	2560	17.2
L1505	L8505	5	1430	4000K	3200	21.5
L1506	L8506	6	1710	4000K	3840	25.8

HIGH OUTPUT LED

Integral Driver Product No	Remote Driver Product No	No of boards	Length (mm)	Colour Temp (Kelvin)	Typical Output (Lumens)	LED (W)
L1602	L8602	2	590	3000K	2260	15.6
L1603	L8603	3	870	3000K	3390	23.4
L1604	L8604	4	1150	3000K	4520	31.2
L1605	L8605	5	1430	3000K	5650	39
L1606	L8606	6	1710	3000K	6780	46.8
L1702	L8702	2	590	4000K	2340	15.6
L1703	L8703	3	870	4000K	3510	23.4
L1704	L8704	4	1150	4000K	4080	31.2
L1705	L8705	5	1430	4000K	5850	39
L1706	L8706	6	1710	4000K	7020	46.8

Microprism lens diffuser is also available, please contact us.

LED Features:-

High colour rendering index CRI >Ra80 as standard
 Small colour tolerance 3 Step MacAdam
 Small luminous flux tolerances
 Colour consistency
 Colour temperature 3000K / 4000K
 Perfectly uniform light when LED modules are used in a line.
 CRI >Ra90 is also available.

Continuous Length - High Efficiency
 L1400/L8400 Series - 3000K
 L1500/L8500 Series - 4000K
 Please contact us for further information. As a guide use multiples of 280mm plus 30mm for tolerance and end caps.

Continuous Length - High Output
 L1600/L8600 Series - 3000K
 L1700/L8700 Series - 4000K
 Please contact us for further information. As a guide use multiples of 280mm plus 30mm for tolerance and end caps.



Tunable White LED is available and allows the colour temperature of white light to be set between 3000K - 6000K. To specify add suffix /TW to the driver product number

Please contact us for further information.

LUMINAIRE DETAIL



High quality LED boards, 3000K / 4000K
CRI >Ra80.

Recessed trim, easy to install, suitable for various ceiling types.

It will be necessary to discuss each project's specific requirements to ensure the correct specification.



LENGTHS

Minimum 2 boards

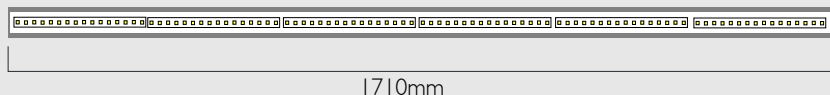
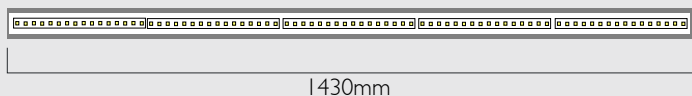
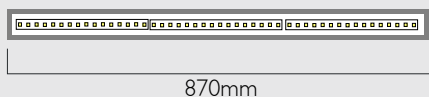
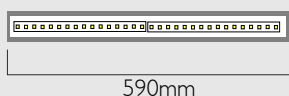

For continuous lengths please contact us for further information. As a guide use multiples of 280mm plus 30mm for tolerance and end caps.

LIGHTLINE LED 60

TRIMLESS

LIGHTLINE LED 60 TRIMLESS Recessed mounting for most ceiling types. It consists of an aluminium extruded profile with minimal edge. Constructed as individual modules in various chassis lengths, which come complete with integral driver. Optical control is provided by a clip in opal diffuser. Microprism lens diffuser is also available.

	High Efficiency	High Output
Typical Luminous flux per 280mm board. @ tp = 65°C	620 lumens, 3000K, 640 lumens, 4000K	1130 lumens, 3000K 1170 lumens, 4000K
CRI (Ra)	>80	>80
Lifetime	50,000	50,000
IP rating	IP40	IP40
Edge Finish	White (RAL 9010)	White (RAL 9010)
Cover / Lens	Opal	Opal
Mounting	Recessed	Recessed
Control	Fixed, DALI, 1-10V, DSI	Fixed, DALI, 1-10V, DSI

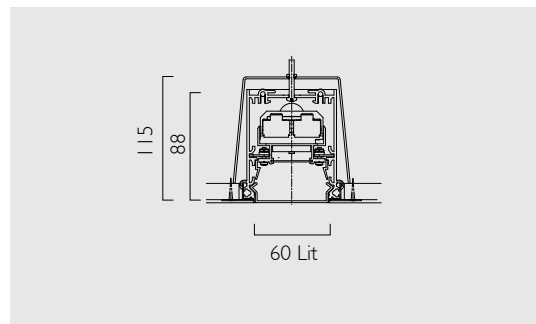
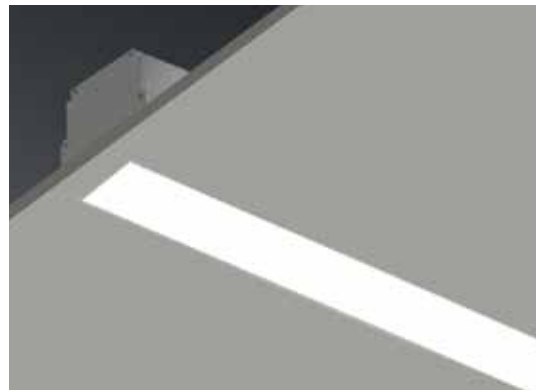

HIGH EFFICIENCY LED

Integral Driver Product No	No of boards	Length (mm)	Colour Temp (Kelvin)	Typical Output (Lumens)	LED (W)
L1802	2	570	3000K	1240	8.6
L1803	3	850	3000K	1860	12.9
L1804	4	1130	3000K	2480	17.2
L1805	5	1410	3000K	3100	21.5
L1806	6	1690	3000K	3720	25.8
L1902	2	570	4000K	1280	8.6
L1903	3	850	4000K	1920	12.9
L1904	4	1130	4000K	2560	17.2
L1905	5	1410	4000K	3200	21.5
L1906	6	1690	4000K	3840	25.8

HIGH OUTPUT LED

Integral Driver Product No	No of boards	Length (mm)	Colour Temp (Kelvin)	Typical Output (Lumens)	LED (W)
L2002	2	570	3000K	2260	15.6
L2003	3	850	3000K	3390	23.4
L2004	4	1130	3000K	4520	31.2
L2005	5	1410	3000K	5650	39
L2006	6	1690	3000K	6780	46.8
L2102	2	570	4000K	2340	15.6
L2103	3	850	4000K	3510	23.4
L2104	4	1130	4000K	4680	31.2
L2105	5	1410	4000K	5850	39
L2106	6	1690	4000K	7020	46.8

Microprism lens diffuser is also available, please contact us.

LED Features:-

High colour rendering index CRI >Ra80 as standard
 Small colour tolerance 3 Step MacAdam
 Small luminous flux tolerances
 Colour consistency
 Colour temperature 3000K / 4000K
 Perfectly uniform light when LED modules are used in a line.
 CRI >Ra90 is also available.

Continuous Length - High Efficiency

L1800 Series - 3000K
 L1900 Series - 4000K
 Please contact us for further information. As a guide use multiples of 280mm plus 10mm for tolerance and end caps.

Continuous Length - High Output

L1600/L8600 Series - 3000K
 L1700/L8700 Series - 4000K
 Please contact us for further information. As a guide use multiples of 280mm plus 30mm for tolerance and end caps.



Tunable White LED is available and allows the colour temperature of white light to be set between 3000K - 6000K. To specify add suffix /TW to the driver product number

Please contact us for further information.



Project: No 1 St James's Market, London

Electrical Installation and Construction:

Balfour Beatty Plc

Architect: Make

Client: The Crown Estate and Oxford Properties

Filling a block between Regent's Street and Haymarket just south of Piccadilly Circus, the building is an interesting mix of a reconstructed Grade II-listed facade with an elegant new addition. As part of this state of the art redevelopment is a beautiful white Corian staircase incorporating a complex Lightline 60 installation, custom designed and tailored to suit the structure.

The site of St James's Market goes as far back as the 1780s when the household name of Wall's foods is first recorded. The butcher, Richard Wall, had a stall selling meat products, perhaps the original incarnation of the famous sausages and pies.



Project: Oxford Brookes University
Architect: Design Engine
M&E Engineer: Grontmij
Lighting Consultant: Speirs + Major
Photographer: Nick Kane

The Oxford Brookes campus has been undergoing refurbishment and redevelopment over several years, and includes the new Abercrombie Building. The upper floors of the building house the Faculty of Technology, Design and Environment and the School of Architecture, whilst the ground floor is part of the wider University scene. The area incorporates a café

and gallery as well as innovative social learning spaces; places to study amongst social activity.

The area was lit with downlighters housed in suspended black channels that were clad with mirror polished steel, which reflects the surrounding daylight and movement.



Project: London Designer Outlet, Wembley
Architect: Leslie Jones Architect
M&E Engineer:
Foreman Roberts Consulting Engineers
Electrical Contractor: AXIS M+E UK Ltd

The regeneration of industrial land close to Wembley Park station includes the exciting new destination, London Designer Outlet, which houses many fashionable designer stores, restaurants and a cinema. Situated close to Wembley Park Station the restaurant terraces and open walkways offer views of the National Stadium arch and the Wembley Arena concert venue.

Along with a selection of standard products, Designed Architectural Lighting worked closely with the design team to design and manufacture various custom LED luminaires, which are integrated with the architectural detail. All with colour changing, the dynamic nature of the lighting installation adds an extra dimension and vibrancy to this exciting shopping and entertainment destination.

LIGHTLINE LED 88

SURFACE / PENDANT

LIGHTLINE LED 88 Surface mounted or Pendant. It consists of an aluminium extruded profile constructed as individual modules in various chassis lengths, which come complete with integral driver.

Optical control is provided by a clip in opal diffuser. Microprism lens diffuser is also available.

	High Efficiency	High Output
Typical Luminous flux per 280mm board. @ tp = 65°C	620 lumens, 3000K, 640 lumens, 4000K	1130 lumens, 3000K 1170 lumens, 4000K
CRI (Ra)	>80	>80
Lifetime	50,000	50,000
IP rating:	IP40	IP40
Finish:	White (RAL 9010)	White (RAL 9010)
Cover / Lens:	Opal	Opal
Mounting:	Surface / Pendant	Surface / Pendant
Control:	Fixed, DALI, 1-10V, DSI	Fixed, DALI, 1-10V, DSI

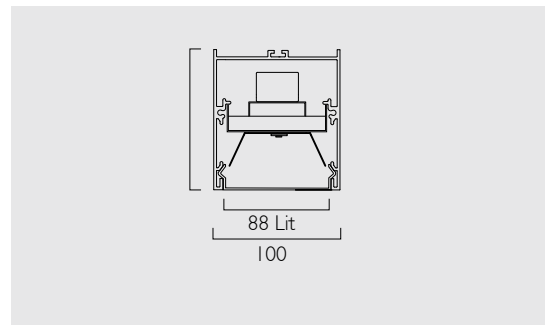
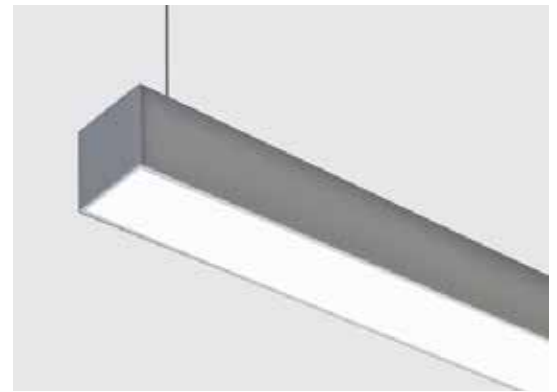

HIGH EFFICIENCY LED

Integral Driver Product No	No of boards	Length (mm)	Colour Temp (Kelvin)	Typical Output (Lumens)	LED (W)
L2202	2	580	3000K	1240	8.6
L2203	3	860	3000K	1860	12.9
L2204	4	1140	3000K	2480	17.2
L2205	5	1420	3000K	3100	21.5
L2206	6	1700	3000K	3720	25.8
L2302	2	580	4000K	1280	8.6
L2303	3	860	4000K	1920	12.9
L2304	4	1140	4000K	2560	17.2
L2305	5	1420	4000K	3200	21.5
L2306	6	1700	4000K	3840	25.8

HIGH OUTPUT LED

Integral Driver Product No	No of boards	Length (mm)	Colour Temp (Kelvin)	Typical Output (Lumens)	LED (W)
L2402	2	580	3000K	2260	15.6
L2403	3	860	3000K	3390	23.4
L2404	4	1140	3000K	4520	31.2
L2405	5	1420	3000K	5650	39
L2406	6	1700	3000K	6780	46.8
L2502	2	580	4000K	2340	15.6
L2503	3	860	4000K	3510	23.4
L2504	4	1140	4000K	4680	31.2
L2505	5	1420	4000K	5850	39
L2506	6	1700	4000K	7020	46.8

Microprism lens diffuser is also available, please contact us.

LED Features:-

High colour rendering index CRI >Ra80 as standard
 Small colour tolerance 3 Step MacAdam
 Small luminous flux tolerances
 Colour consistency
 Colour temperature 3000K / 4000K
 Perfectly uniform light when LED modules are used in a line.
 CRI >Ra90 is also available.

Continuous Length - High Efficiency
 L2200 Series - 3000K
 L2300 Series - 4000K
 Please contact us for further information. As a guide use multiples of 280mm plus 20mm for tolerance and end caps.

Continuous Length - High Output
 L2400 Series - 3000K
 L2500 Series - 4000K
 Please contact us for further information. As a guide use multiples of 280mm plus 20mm for tolerance and end caps.



Tunable White LED is available and allows the colour temperature of white light to be set between 3000K - 6000K. To specify add suffix /TW to the driver product number

Please contact us for further information.

LUMINAIRE DETAIL



High quality LED boards, 3000K / 4000K
CRI >Ra80.



Surface or pendant, with integral driver and integral emergency option.

It will be necessary to discuss each project's specific requirements to ensure the correct specification.

LENGTHS

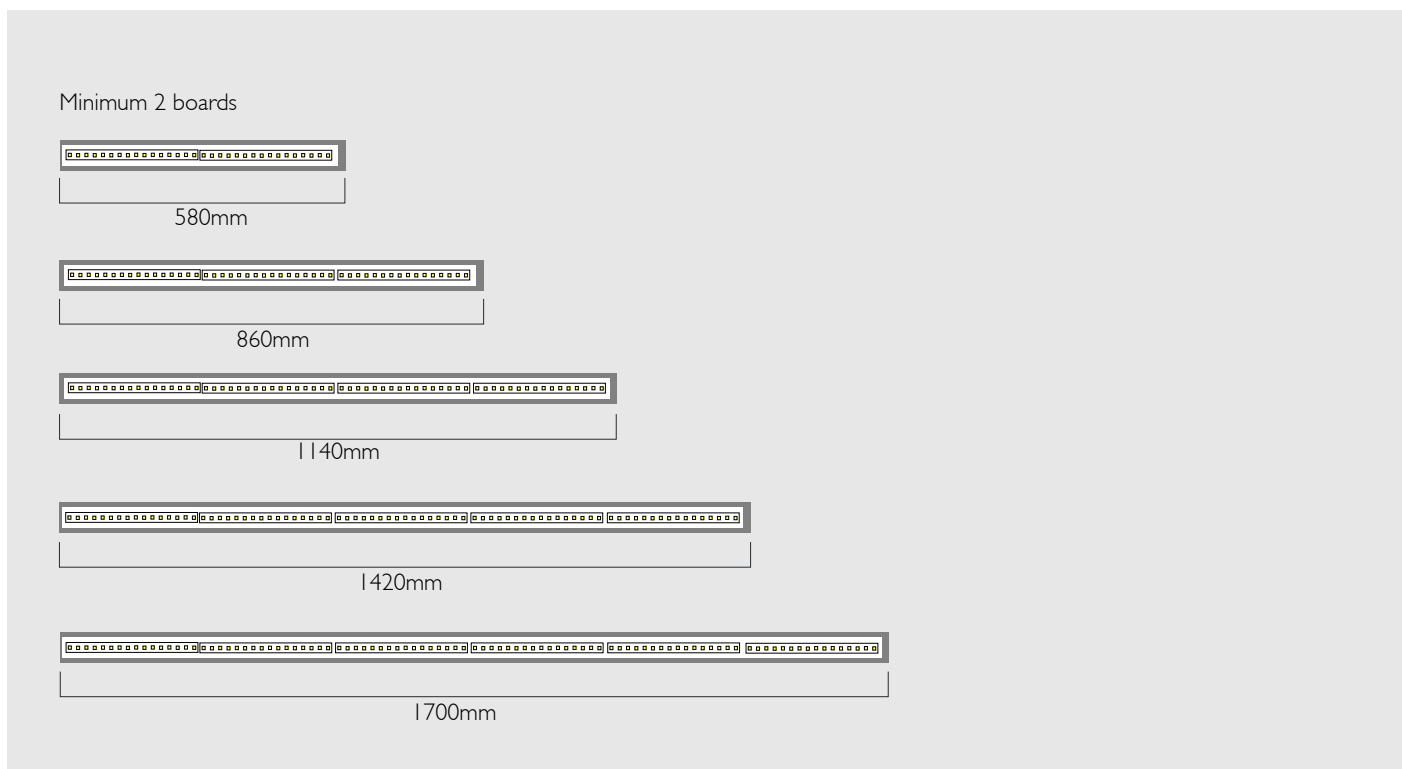

For continuous lengths please contact us for further information. As a guide use multiples of 280mm plus 20mm for tolerance and end caps.

LIGHTLINE LED 88

RECESSED WITH TRIM

LIGHTLINE LED 88 Recessed mounting for most ceiling types. It consists of an aluminium extruded profile with ceiling trim. Constructed as individual modules in various chassis lengths, which come complete with integral driver. Optical control is provided by a clip in opal diffuser. Microprism lens diffuser is also available.

	High Efficiency	High Output
Typical Luminous flux per 280mm board. @ tp = 65°C	620 lumens, 3000K, 640 lumens, 4000K	1130 lumens, 3000K 1170 lumens, 4000K
CRI (Ra)	>80	>Ra80
Lifetime	50,000	50,000
IP rating:	IP40	IP40
Trim Finish:	White (RAL 9010)	White (RAL 9010)
Cover / Lens:	Opal	Opal
Mounting:	Recessed	Recessed
Control:	Fixed, DALI, I-10V, DSI	Fixed, DALI, I-10V, DSI

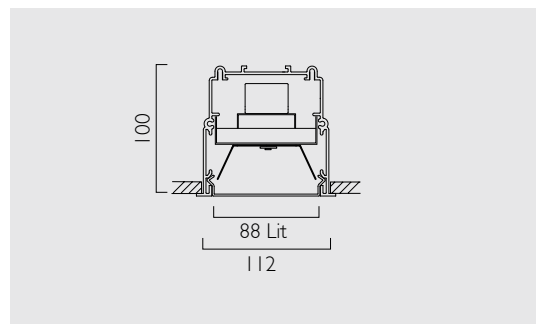
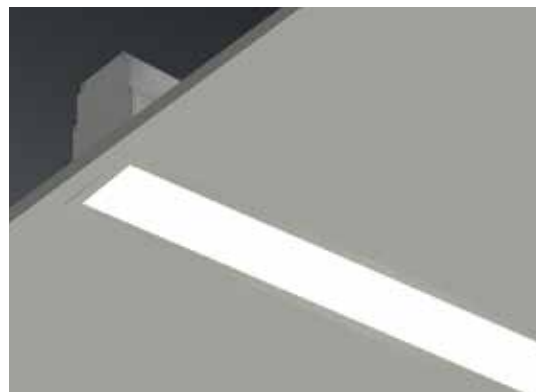

HIGH EFFICIENCY LED

Integral Driver Product No	No of boards	Length (mm)	Colour Temp (Kelvin)	Typical Output (Lumens)	LED (W)
L2602	2	590	3000K	1240	8.6
L2603	3	870	3000K	1860	12.9
L2604	4	1150	3000K	2480	17.2
L2605	5	1430	3000K	3100	21.5
L2606	6	1710	3000K	3720	25.8
L2702	2	590	4000K	1280	8.6
L2703	3	870	4000K	1920	12.9
L2704	4	1150	4000K	2500	17.2
L2705	5	1430	4000K	3200	21.5
L2706	6	1710	4000K	3840	25.8

HIGH OUTPUT LED

Integral Driver Product No	No of boards	Length (mm)	Colour Temp (Kelvin)	Typical Output (Lumens)	LED (W)
L2802	2	590	3000K	2260	15.6
L2803	3	870	3000K	3390	23.4
L2804	4	1150	3000K	4520	31.2
L2805	5	1430	3000K	5650	39
L2806	6	1710	3000K	6780	46.8
L2902	2	590	4000K	2340	15.6
L2903	3	870	4000K	3510	23.4
L2904	4	1150	4000K	4680	31.2
L2905	5	1430	4000K	5850	39
L2906	6	1710	4000K	7020	46.8

Microprism lens diffuser is also available, please contact us.

LED Features:-

High colour rendering index CRI >Ra80 as standard
 Small colour tolerance 3 Step MacAdam
 Small luminous flux tolerances
 Colour consistency
 Colour temperature 3000K / 4000K
 Perfectly uniform light when LED modules are used in a line.
 CRI >Ra90 is also available.

Continuous Length - High Efficiency
 L2600 Series - 3000K
 L2700 Series - 4000K
 Please contact us for further information. As a guide use multiples of 280mm plus 30mm for tolerance and end caps.

Continuous Length - High Output
 L2400 Series - 3000K
 L2500 Series - 4000K
 Please contact us for further information. As a guide use multiples of 280mm plus 20mm for tolerance and end caps.



Tunable White LED is available and allows the colour temperature of white light to be set between 3000K - 6000K. To specify add suffix /TW to the driver product number

Please contact us for further information.

LUMINAIRE DETAIL



High quality LED boards, 3000K / 4000K
CRI >Ra80.



Recessed trim, easy to install, suitable for various ceiling types.

It will be necessary to discuss each project's specific requirements to ensure the correct specification.

LENGTHS

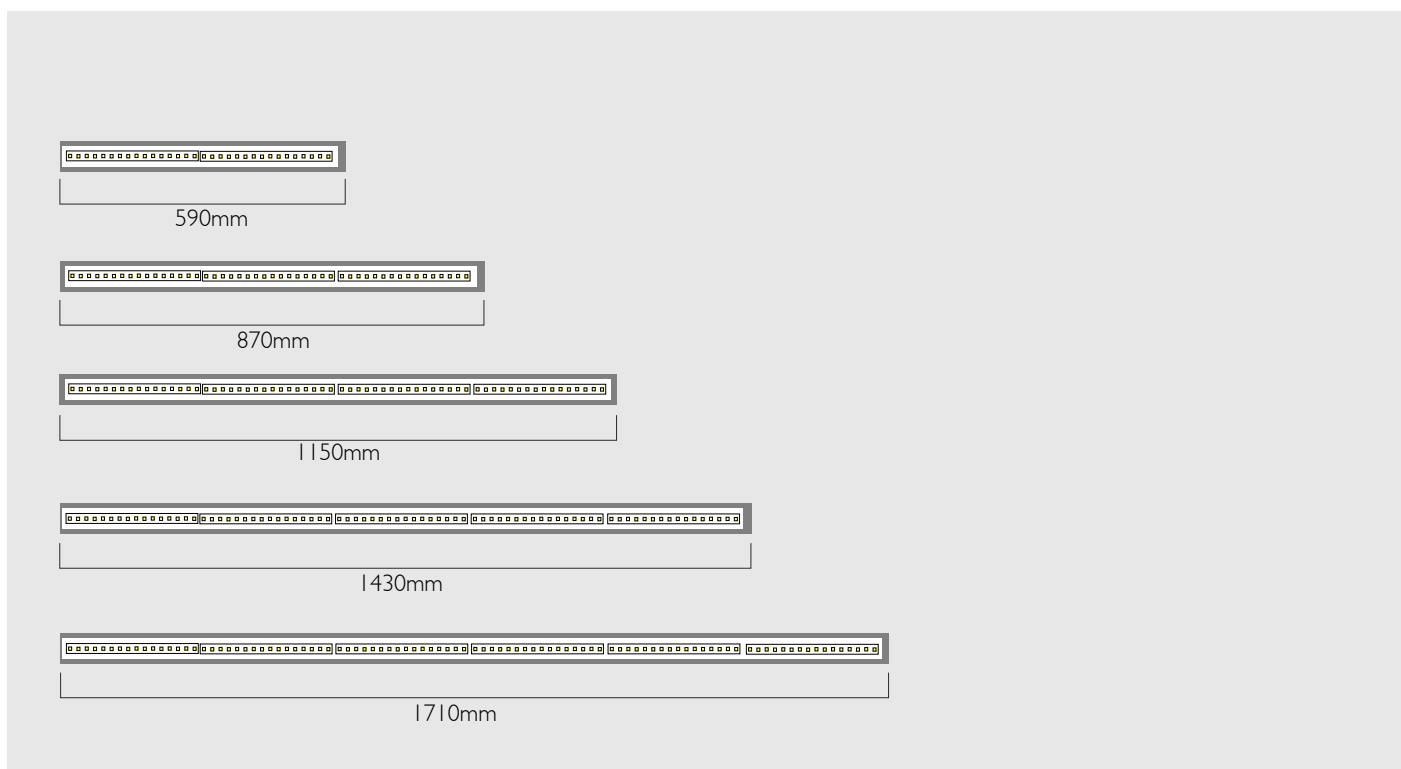

For continuous lengths please contact us for further information. As a guide use multiples of 280mm plus 30mm for tolerance and end caps.

When accent or highlighting is needed, QUINTA or similar style downlighters can be supplied within LIGHTLINE 88. Additional downlight modules can be integrated as required.



LIGHTLINE LED 88

TRIMLESS

LIGHTLINE LED 88 TRIMLESS Recessed mounting for most ceiling types. It consists of an aluminium extruded profile with minimal edge. Constructed as individual modules in various chassis lengths and comes complete with integral driver. Optical control is provided by a clip in opal diffuser. Microprism lens diffuser is also available.

	High Efficiency	High Output
Typical Luminous flux per 280mm board. @ tp = 65°C	620 lumens, 3000K, 640 lumens, 4000K	1130 lumens, 3000K 1170 lumens, 4000K
CRI (Ra)	>80	>80
Lifetime	50,000	50,000
IP rating:	IP40	IP40
Edge Finish:	White (RAL 9010)	White (RAL 9010)
Cover / Lens:	Opal	Opal
Mounting:	Recessed	Recessed
Control:	Fixed, DALI, 1-10V, DSI	Fixed, DALI, 1-10V, DSI

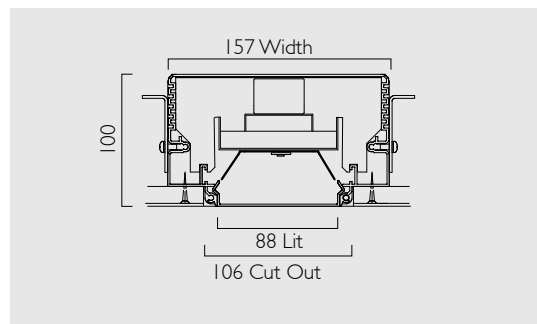
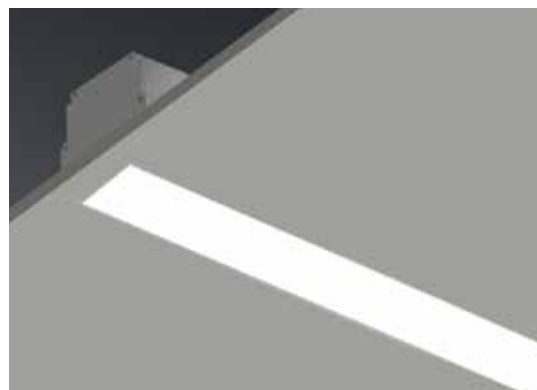

HIGH EFFICIENCY LED

High Efficiency Product No	No of boards	Length (mm)	Colour Temp (Kelvin)	Typical Output (Lumens)	LED (W)
L3002	2	570	3000K	1240	8.6
L3003	3	850	3000K	1860	12.9
L3004	4	1130	3000K	2480	17.2
L3005	5	1410	3000K	3100	21.5
L3006	6	1690	3000K	3720	25.8
L3102	2	570	4000K	1280	8.6
L3103	3	850	4000K	1920	12.9
L3104	4	1130	4000K	2560	17.2
L3105	5	1410	4000K	3200	21.5
L3106	6	1690	4000K	3840	25.8

HIGH OUTPUT LED

High Output Product No	No of boards	Length (mm)	Colour Temp (Kelvin)	Typical Output (Lumens)	LED (W)
L3202	2	570	3000K	2260	15.6
L3203	3	850	3000K	3390	23.4
L3204	4	1130	3000K	4520	31.2
L3205	5	1410	3000K	5650	39
L3206	6	1690	3000K	6780	46.8
L3302	2	570	4000K	2340	15.6
L3303	3	850	4000K	3510	23.4
L3304	4	1130	4000K	4680	31.2
L3305	5	1410	4000K	5850	39
L3306	6	1690	4000K	7020	46.8

Microprism lens diffuser is also available, please contact us.

LED Features:-

High colour rendering index CRI >Ra80 as standard
 Small colour tolerance 3 Step MacAdam
 Small luminous flux tolerances
 Colour consistency
 Colour temperature 3000K / 4000K
 Perfectly uniform light when LED modules are used in a line.
 CRI >Ra90 is also available.

Continuous Length - High Efficiency
 L3000 Series - 3000K
 L3100 Series - 4000K
 Please contact us for further information. As a guide use multiples of 280mm plus 10mm for tolerance and end caps.

Continuous Length - High Output
 L3200 Series - 3000K
 L3300 Series - 4000K
 Please contact us for further information. As a guide use multiples of 280mm plus 10mm for tolerance and end caps.



Tunable White LED is available and allows the colour temperature of white light to be set between 3000K - 6000K. To specify add suffix /TW to the driver product number

Please contact us for further information.

LUMINAIRE DETAIL



High quality LED boards, 3000K / 4000K
CRI >Ra80.



Secure plaster-in installation.

It will be necessary to discuss each project's specific requirements to ensure the correct specification.

LENGTHS

Minimum 2 boards



570mm



860mm



1130mm



1410mm



1690mm

For continuous lengths please contact us for further information. As a guide use multiples of 280mm plus 10mm for tolerance and end caps.

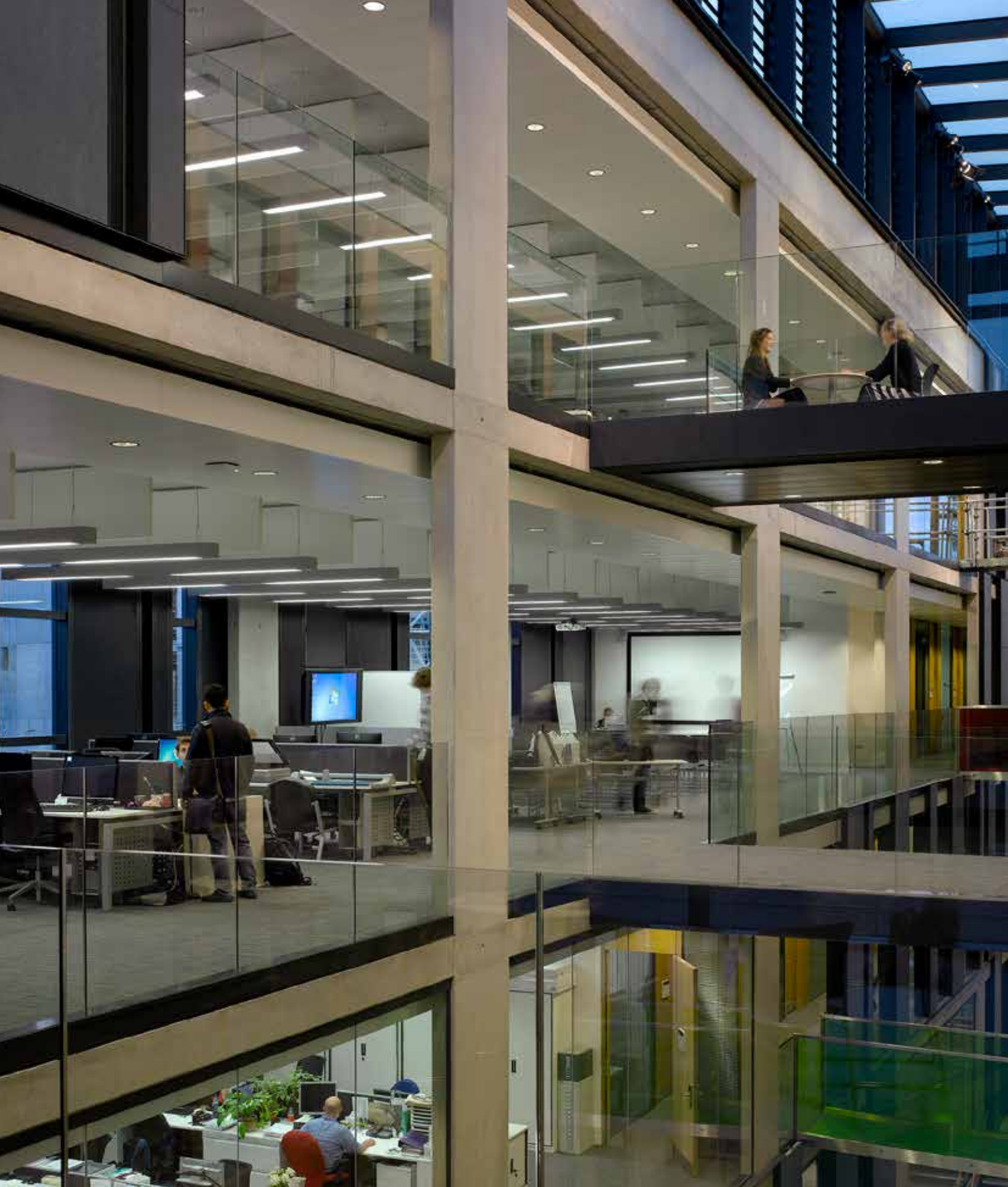

Project: Oxford Brookes University
Architect: Design Engine
M&E Engineer: Grontmij
Lighting Consultant: Spiers + Major
Photographer: Nick Kane

The Abercrombie Building, Headington Campus, is part of Oxford Brookes University and situated in a residential area about one mile east of Oxford city centre. For DAL the project started with the Abercrombie Building extension, the first phase of the much larger John Henry Brookes Building. The extension is linked to the existing building by glass bridges and shared meeting galleries, forming a dramatic interior with internal spaces opening onto

The Void, which allows natural ventilation and lots of daylight.

With the team DAL developed a linear lighting and services system for the project. This, together with surface mounted and recessed downlighters, including AMBIANCE X100 downlighters, forms a cohesive lighting strategy for New Teaching and Library Building.

BORDO 150

Bordo 150 is linear luminaire designed to create neat lines of light on the ceiling. It is available in surface mounted or suspended. It can be supplied as individual modules or modules to create continuous runs. Complete with integral drivers.

Designed Architectural Lighting is a flexible, customer friendly company and Bordo can be supplied in a variety of colour finishes if required.

Bordo 150 luminaires have the following features:

- Robust extruded aluminium construction
- Sharp edge detail
- Easily installed components
- Integral reflector
- Surface and pendant versions finished metallic silver
- Drivers are integral.
- Driver options are: non-dimmable or dimmable protocols: 1-10v, DSI, DALI, Lead/trailing edge.

LED Features:

- High colour rendering index CRI (Ra) >80
- Small colour tolerance
- Small luminous flux tolerances
- Good colour consistency
- Colour temperature 3000K / 4000K
- Perfectly uniform light, even if several LED modules are used in a line.

SURFACE / PENDANT

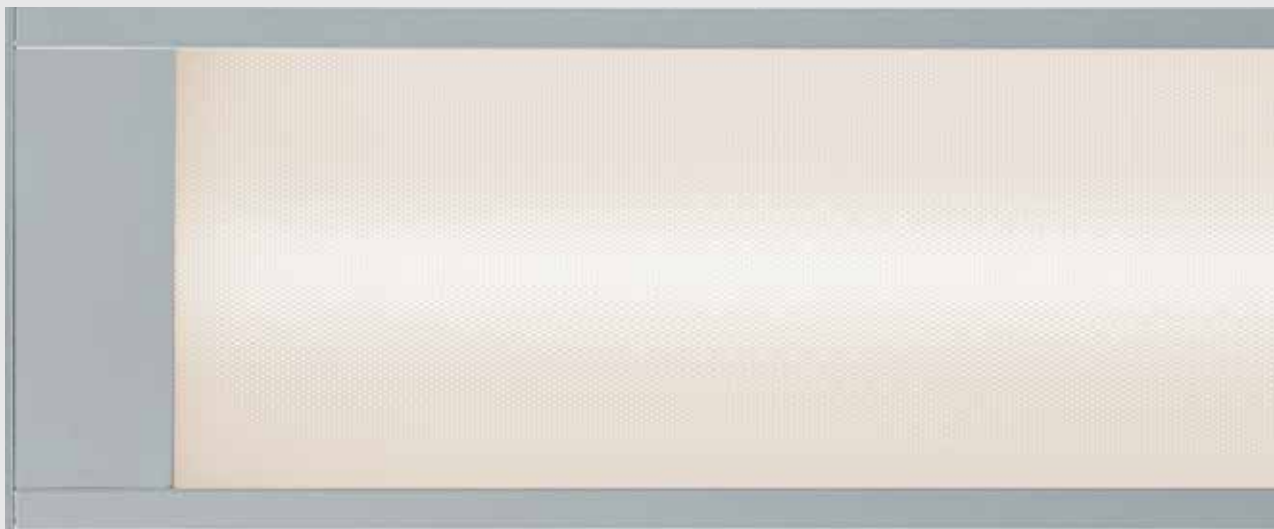

BORDO LED I50

Bordo T150 is a highly efficient, bespoke, multi-functional linear lighting system, utilising the latest in LED technology. DAL has developed Bordo T150 with many of today's building services requirements in mind. It is flexible, enabling the integration of most occupier and safety sensors. Able to be supplied as individual modules or as a continuous system

Bordo I50 is primarily a bespoke system, it will be necessary to discuss each project's specific requirements to ensure the correct specification.

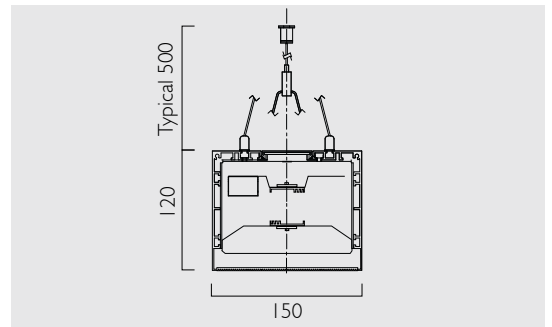

	High Efficiency	High Output
Typical Luminous flux per 280mm board. @ tp = 65°C	630 lumens, 3000K, 650 lumens, 4000K	1140 lumens, 3000K 1190 lumens, 4000K
CRI (Ra)	>80	>80
Lifetime	50,000	50,000
IP rating:	IP20	IP20
Finish:	White (RAL 9010)	White (RAL 9010)
Cover / Lens:	Opal	Opal
Mounting:	Surface / Pendant	Surface / Pendant
Control:	Non-dimmable or dimmable	Non-dimmable or dimmable

Product No	Length	Colour Temp (Kelvin)	Typical Output (Lms)
L4000 Series	Various	3000K	see above
L4100 Series	Various	4000K	see above

LEDs (Light-emitting diodes) generate light using the special electronic properties of crystalline semiconductors and solid state technology. As well as being free of ultraviolet radiation, LEDs have very low infrared radiation in the beam.

Advantages of LEDs Include:
 Long life resulting in low maintenance costs
 Cool beams of light
 No ultraviolet
 Low infrared
 Mercury free / Lead free
 Low energy

High luminous efficacy (lms/w)
 Colour stability
 Instant light
 High performance
 Precise optical control
 Emergency options
 Dimmable

LUMINAIRE DETAIL



High quality LED boards, 3000K / 4000K CRI >Ra80.



Integrated infill panels allows ease of installation and design flexibility and can incorporate presence detectors, daylight sensors, smoke detectors and speakers.



Additional downlighters or spotlights can also be incorporated. The standard finish is metallic silver RAL 9006.



The uplight component comprises an LED board, shallow depth white reflector and soft light lens.

EXAMPLE RUNS

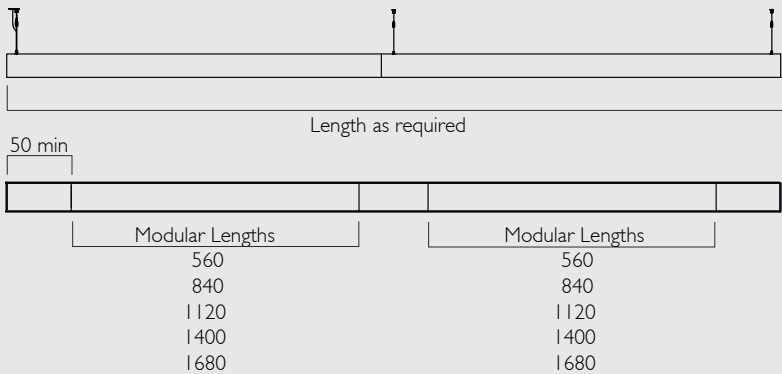

Please note: Infill panels are normally of equal length

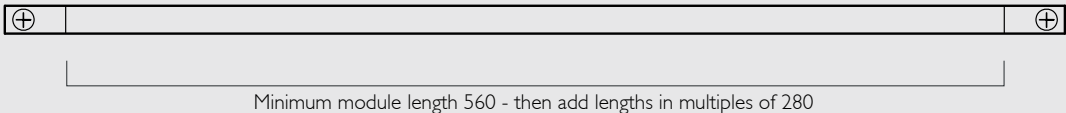
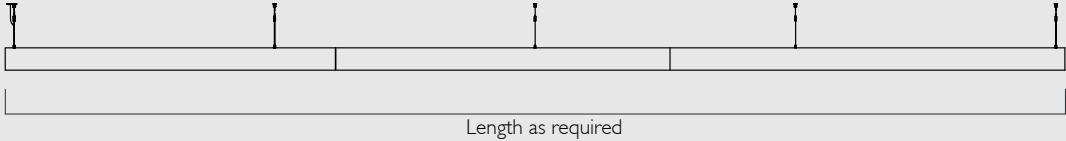

WALLWASHER LED

WALLWASHER LED recessed luminaire consists of an extruded aluminium mounting chassis and precise optic double reflector and lens, white RAL 9010 ceiling trim.

WALLWASHER LED is primarily a bespoke system, it will be necessary to discuss each project's specific requirements to ensure the correct specification.

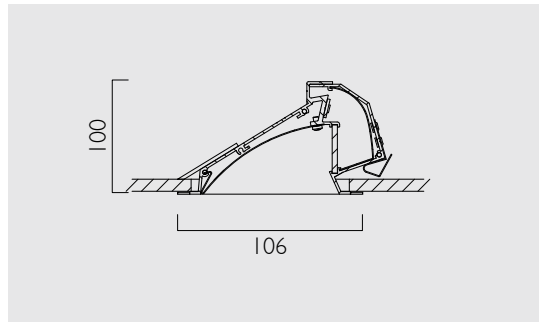

	3000K	4000K
Luminous flux per metre.	1789 lms/m	1841 lms/m
Beam Angle:	Even Wallwasher	Even Wallwasher
CRI (Ra):	>85	>85
Lifetime	50,000	50,000
IP rating:	IP20	IP20
Finish:	White RAL 9010	White RAL 9010
Cover / Lens:	Opal Diffuser	Opal Diffuser
Mounting:	Recessed	Recessed
Control:	24V - Non-dimmable or dimmable	24V - Non-dimmable or dimmable

Typical Criteria

High Output Product No	Length (mm)	Colour Temp (Kelvin)	Typical Output (Lms)	LED (W)
L4203	527	3000K	894	11.5
L4204	869	3000K	1341	17.2
L4206	1040	3000K	1789	23
L4303	527	4000K	920	11.5
L4304	869	4000K	1380	17.2
L4306	1040	4000K	1841	23

Other Colour Temperature and lengths are available

LENGTHS

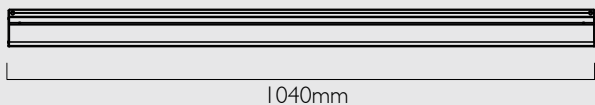
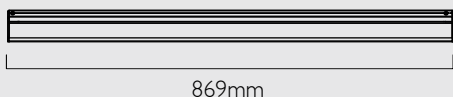
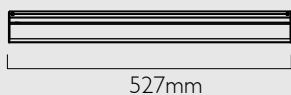

Longer lengths or continuous runs can be supplied to order

Private Airline Lounges, Stansted Airport
Lighting Consultant: Paul Nulty, PNL
Photographer: © Sanna Fisher-Payne



DETAILS

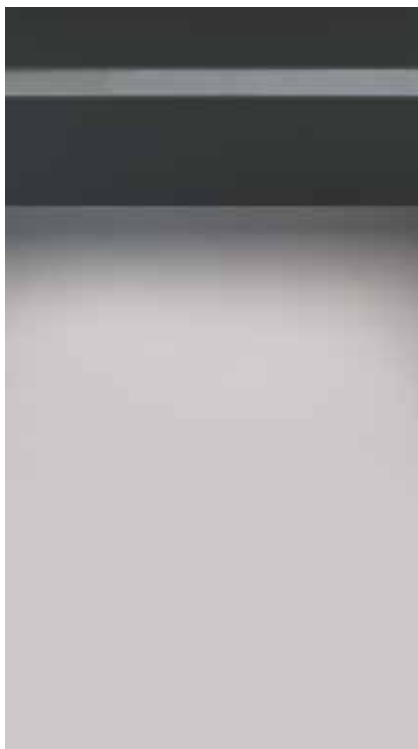

Perfectly uniform light.
Luminaire position: 0.8m from the wall.



Asymmetric distribution, with double reflector and opal diffuser ensures the light reaches high up the wall.



LED Linear CRI Ra85, 3 Step MacAdam

COVELINE LED

COVELINE LED can be surface mounted or neatly recessed. It consists of an aluminium extruded profile constructed as individual modules in various chassis lengths, which come complete with remote driver.
Optical control is provided by a clip in opal diffuser.

COVELINE LED is primarily a bespoke system, it will be necessary to discuss each project's specific requirements to ensure the correct specification.

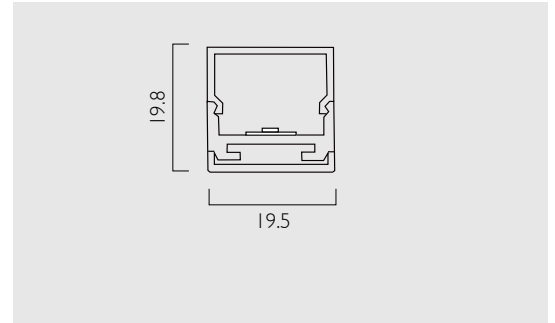

LED Features:-
 Small colour tolerance 3 step MacAdam
 Small luminous flux tolerances
 Colour consistency
 Colour temperature 3000K / 4000K

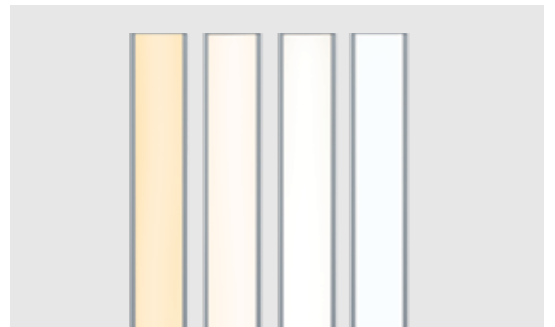

Tunable White LED is available and allows the colour temperature of white light to be set between 3000K - 6000K. To specify add suffix /TW to the driver product number

Please contact us for further information.

	3000K	4000K
Luminous flux per meter	1789 lms/m	1841 lms/m
CRI:	>85	>85
Lifetime	50,000	50,000
IP rating:	IP20	IP20
Body Finish:	Silver	Silver
Cover / Lens:	Opal Diffuser / Clear	Opal Diffuser / Clear
Mounting:	Surface	Surface
Control:	DALI, DMX/RDM, LedSync, 0-10V and Switch-dim compatible.	DALI, DMX/RDM, LedSync, 0-10V and Switch-dim compatible.

Typical Criteria

High Output Product No	Length (mm)	Colour Temp (Kelvin)	Typical Output (Lumens)	LED (W)
L4406	1026	3000K	1789	23
L4412	2052	3000K	3578	46
L4418	3078	3000K	5367	69
L4424	4104	3000K	7156	92
L4506	1026	4000K	1841	23
L4512	2052	4000K	3682	46
L4518	3078	4000K	5523	69
L4524	4104	4000K	7364	92

Other Colour Temperature and lengths are available

LENGTHS

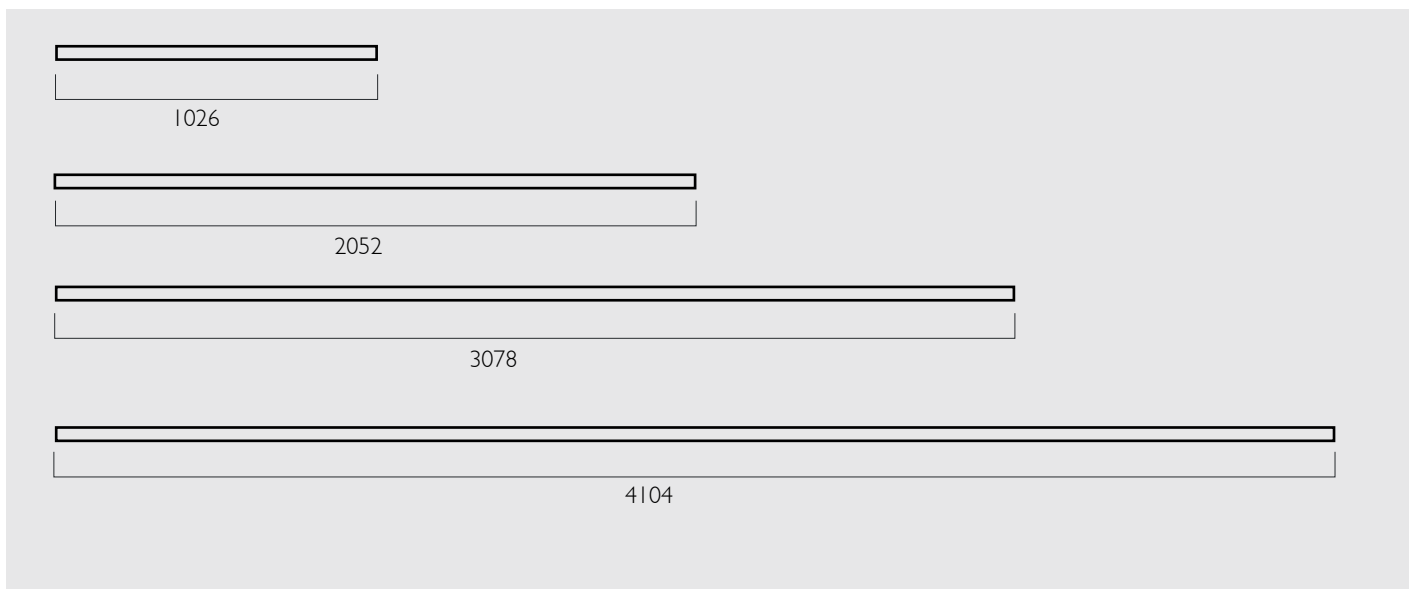



Bicester Village Station, Oxfordshire
 Architect: Lyons Sleeman Hoare
 M&E Engineer: Furness Green Partnership

This unusual station design utilises high quality materials and artisan finishes. The lighting design is not merely functional but uses stylish lanterns and LED COVELINE mounted in finely detailed ceiling coves.

DETAILS



COVELINE LED is often used for edge lighting. The physical size and offset of the cove will influence the lit effect.



Extruded aluminium heat-sink and end caps.
 Protective opal diffuser cover (as standard).



Protective clear cover (subject to availability).

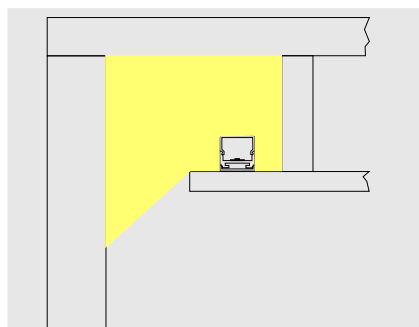

Easy installation and maintenance. Remote driver:



Efficient soft glow.



Gun Wharf, Portsmouth
Lighting Consultant: BDP Lighting
Design: Orium Design Ltd
M&E Engineer: Hulley and Kirkwood

Gunwharf Quays is located on the waterfront close to the Spinnaker Tower, Portsmouth's iconic landmark. Once a Royal dock with servicing areas for cannons, ammunition and other armaments it is now a vibrant retail destination full of shops, cafés and restaurants.

Known locally as The Quays, the high-end retail outlet, shopping centre and social hub has a buzz about it. The development is a mix of renovated buildings and contemporary areas that have been

designed to follow the traditional warehouse character.

Originally opened in 2001 it has been recently refurbished. DAL GRAZER is used as part of the lighting concept to create a dramatic up-light effect. Tucked neatly above the shop fronts the GRAZER's close offset narrow beam LEDs enhance the detailed decorative plaster work, whilst adding height and lightness to the space.

GRAZER LED

GRAZER LED uses multi lens technology which allows precision and control of individual LEDs. It has rotation adjustment to fulfill different lighting effects, from close off-set grazing to less intense ceiling and wallwash effects.



GRAZER LED

GRAZER LED can be surface mounted or suspended from the ceiling. It consists of an aluminium extruded profile in various chassis lengths as individual modules and comes complete with integral driver.

Optical control is provided by precise lenses.

Typical Criteria

	3000K	4000K
Luminous flux per 6 x LED at 700mA	Total 762 lumens per board	Total 845 lumens per board
Beam Angle:	10° x 40°	10° x 40°
CRI: (Ra)	>80	>80
Lifetime	50,000	50,000
IP rating:	IP20	IP20
Finish:	Black RAL 9005	Black RAL 9005
Cover / Lens:	Clear / Elliptical	Clear / Elliptical
Mounting:	Surface / Pendant	Surface / Pendant
Control:	Non-dimmable or dimmable	Non-dimmable or dimmable

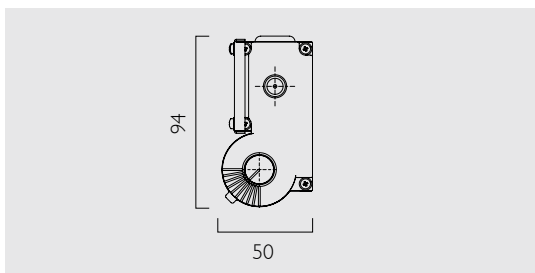

Product No	Length	Colour Temp (Kelvin)	Typical Output (Lumens)	Product No	Length	Colour Temp (Kelvin)	Typical Output (Lumens)
L4601	346	3000K	762	L4701	346	4000K	845
L4602	646	3000K	1524	L4702	646	4000K	1690
L4603	946	3000K	2286	L4703	946	4000K	2535
L4604	1246	3000K	3048	L4704	1246	4000K	3380

PROJECTOR LED

PROJECTOR LED can be surface mounted. It consists of an aluminium extruded profile in various chassis lengths as individual modules, and comes complete with integral driver.

Typical Criteria

High Efficiency

Typical Luminous flux per 280mm board. @ tp = 65°C
630 lumens, 3000K,
650 lumens, 4000K

CRI (Ra)	>80
Lifetime	50,000
IP rating:	IP20
Finish:	Various
Cover / Lens:	Opal
Mounting:	Surface / Pendant
Control:	Non-dimmable or dimmable

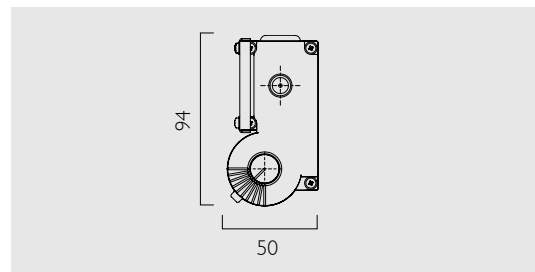
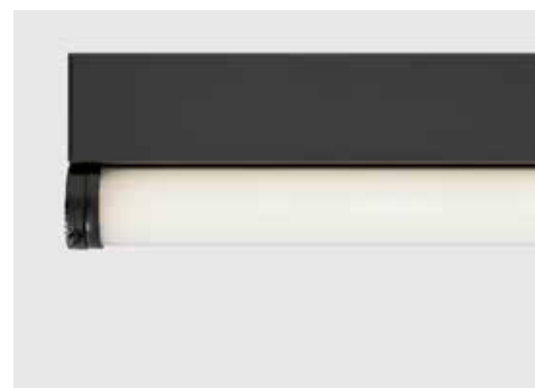

Product No	Length	Colour Temp (Kelvin)	Typical Output (Lumens)	Product No	Length	Colour Temp (Kelvin)	Typical Output (Lumens)
L3802	604	3000K	1260	L3902	604	4000K	1300
L3803	886	3000K	1890	L3903	886	4000K	1950
L3804	1168	3000K	2520	L3904	1168	4000K	2600
L3805	1450	3000K	3150	L3905	1450	4000K	3250

GRAZER LED and PROJECTOR LED are primarily bespoke systems, it will be necessary to discuss each project's specific requirements to ensure the correct specification.

DETAILS



Design features:

GRAZER LED uses multi lens technology, which allows precision and control of individual LEDs. It has rotational adjustment to fulfill different lighting effects. Integral driver as standard.

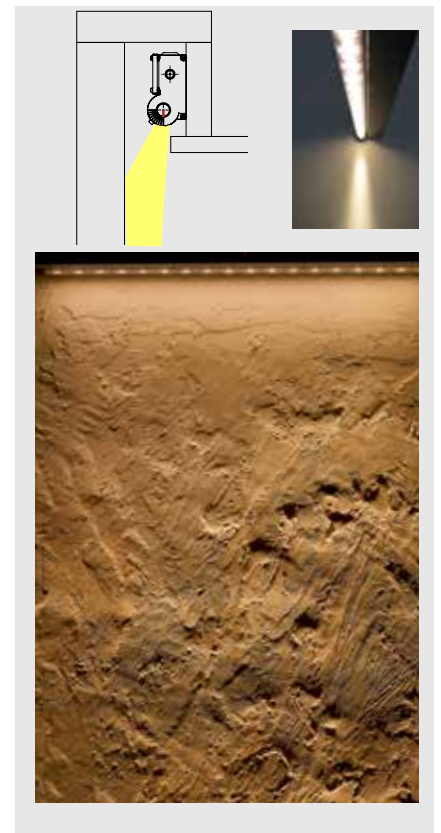
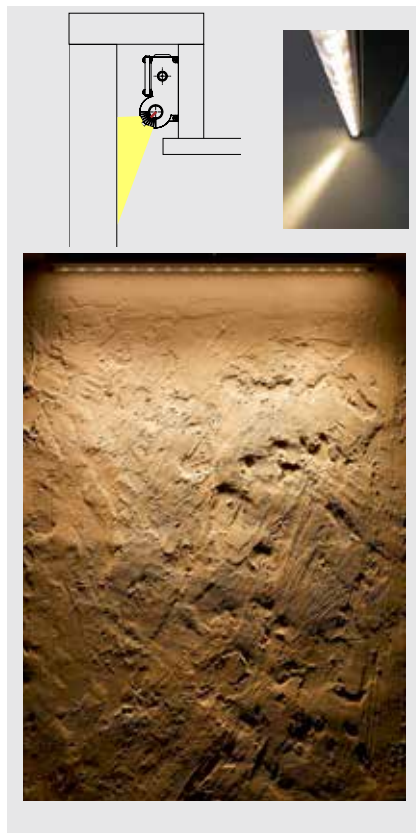
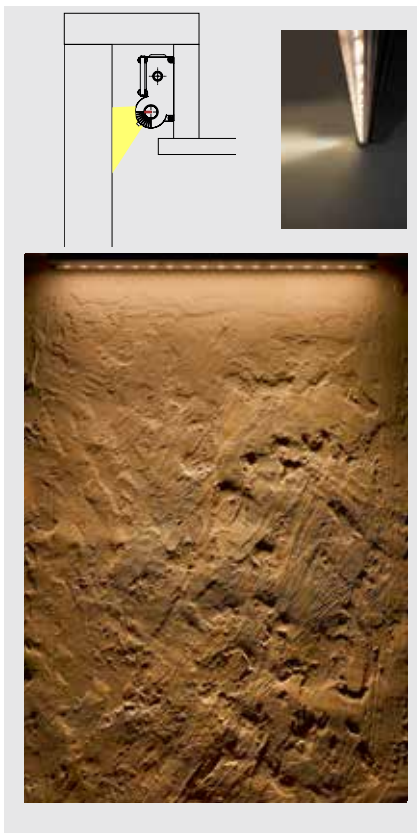

LENGTHS

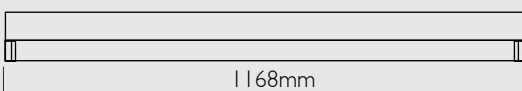



Project: London Designer Outlet, Wembley
Architect: Leslie Jones Architect
M&E Engineer:
Foreman Roberts Consulting Engineers
Electrical Contractor: AXIS M+E UK Ltd

The regeneration of the industrial land close to Wembley Park station includes the London Designer Outlet, which houses many fashionable designer stores, restaurants and a multiplex cinema. The restaurant terraces and open walkways offer views of the National Stadium arch and the Wembley Arena concert venue.

Along with a selection of standard products DAL worked closely with the design team to design and manufacture various custom LED luminaires, which are integrated with the architectural detail. All with colour changing technology, the dynamic nature of the lighting installation adds an extra dimension and vibrancy to this exciting shopping and entertainment destination.



Project: The Oculus and Octagon Gallery,
University College London
Architect: Burwell Deakins Architects
M&E Engineer: Fowler Martin

The Flaxman Gallery, in the Wilkins building at UCL, houses many of John Flaxman's models. Flaxman was a neoclassical sculptor and these are his preparatory designs for sculptures such as the memorial to Lord Nelson in St Paul's Cathedral. Recently, the area around the statue of St Michael Overcoming Satan was ingeniously opened up, allowing a view upwards from the new exhibition space below in the Octagon. This not only forms a visual link between the spaces but also allows daylight through from the windows in the dome above.

PROJECTOR LED luminaires were used to wash-light the floor and ceiling.

TERRA LED 150

FLOOR RECESSED

TERRA LED 150 is a floor recessed linear system for interior use. It consists of an aluminium extruded profile constructed as individual modules in various chassis lengths, toughened glass diffuser and come complete with integral driver.

TERRA LED150 is primarily a bespoke system, it will be necessary to discuss each project's specific requirements to ensure the correct specification.

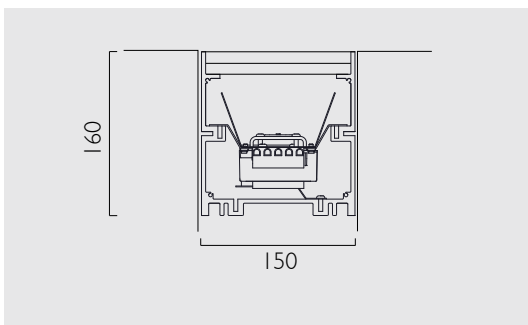

LED Features:

- High colour rendering index CRI >Ra80
- Small colour tolerance 3 step MacAdam
- Small luminous flux tolerances
- Colour consistency
- Colour temperature 3000K / 4000K
- Perfectly uniform light.
- LM 79 and LM 80 compliant

	High Efficiency	High Output
Typical Luminous flux per 280mm board. @ tp = 65°C	630 lumens, 3000K, 650 lumens, 4000K	1140 lumens, 3000K 1190 lumens, 4000K
Minimum no of boards	2	2
CRI (Ra)	>80	>80
Lifetime	50,000	50,000
Operating temp:	tp = 25°C to 65°C	tp = 25°C to 65°C
IP rating:	IP44	IP44
Finish:	White (RAL 9010)	White (RAL 9010)
Cover / Lens:	Opal	Opal
Mounting:	Surface / Pendant	Surface / Pendant
Control:	Non-dimmable or dimmable	Non-dimmable or dimmable

Product No	Length	Colour Temp (Kelvin)	Typical Output (Lumens)
L4800 series	Various	3000K	see above
L4900 series	Various	4000K	see above

LUMINAIRE DETAIL



LED CRI Ra85, 3 Step MacAdam

Private Airline Lounges, Stansted Airport
 Lighting Consultant: Paul Nulty, PNLD
 Photographer: © Sanna Fisher-Payne

EXAMPLE RUN

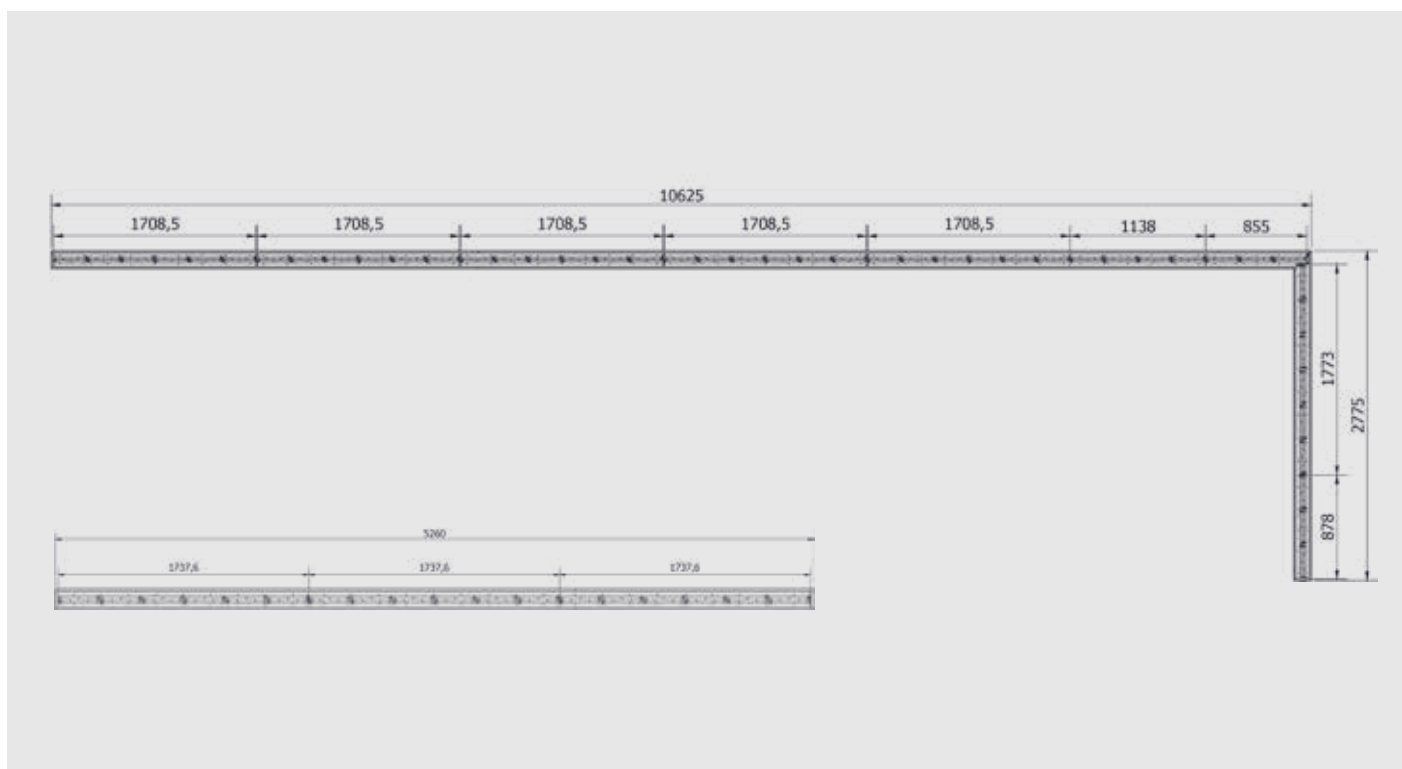



The Beany House of Art and Knowledge, Canterbury
Architect: John Miller & Partners with Sidell Gibson.
Lighting Specialist: Lightwaves

The refurbished Beany included the restoration of the illuminated ceiling in the picture gallery originally built in 1934. A state-of-the-art gallery space was added to the building's amenities, which allows layout changes for the temporary exhibitions the Beany now hosts.

As part of overall lighting strategy DAL's BALTIC spotlight was specified for its unique functionality. The spotlights are fully track mountable, have interchangeable components and is designed specifically for regular adjustment. BALTIC offers a range of beam widths and are individually dimmable.

GALLERY LIGHTING SPOTLIGHTS & WASHLIGHTS

DAL developed the BALTIC spotlight and the IKON LED WASHLIGHT with the needs of art gallery, museum and exhibition curators and designers in mind.

BALTIC has an integral dimmable driver with a rotary on-board dimmer switch and the specifier has a choice of Xicato LED light engine with >Ra80 or >Ra98 colour rendering and interchangeable reflectors. The standard finish is white. BALTIC is also fully adjustable and lockable; the perfect lighting solution for accurate and controllable lighting.

IKON WASHLIGHT has an integral dimmable driver with a rotary on-board dimmer switch. It also has a dual switch colour choice of 3000K or 4000K.

Both are suitable for track mounting, universal 3 circuit type adaptors comes as standard.

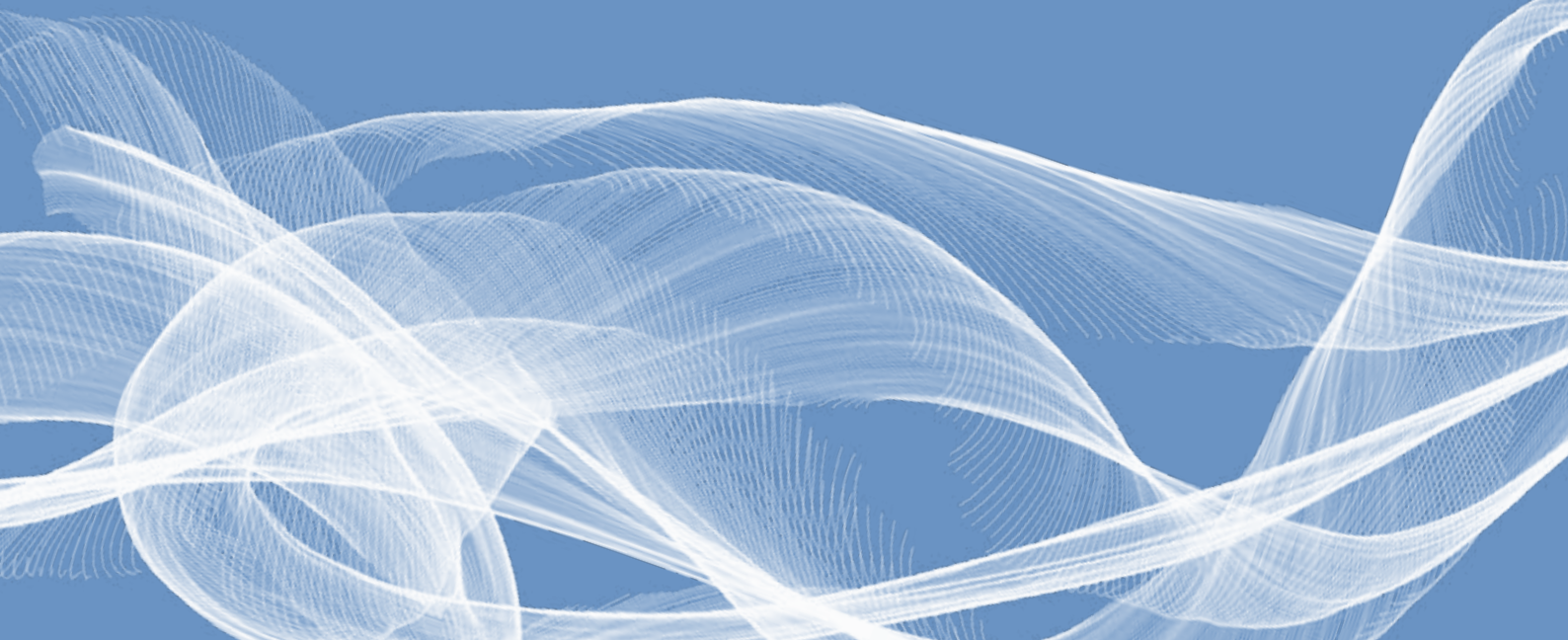



Tate Britain, London
Lighting Designer: John Johnson, Lightwaves

The Tate Britain is situated on Millbank, by the Thames River on the site of the former Millbank Prison. The original gallery spaces were opened in 1897 and are commonly known as the Tate, after Sir Henry Tate, the founder. It was renamed Tate Britain in 2000, becoming the home of historical and contemporary British art. The BALTIC spotlight is used extensively throughout Tate Britain and Tate Modern.



The Baltic Story

The Baltic spotlight range was developed with the needs of art gallery, museum, exhibition curators and designers in mind; those planning lighting levels and lit effects; those installing and aiming spotlights whilst high up ladders or scaffold towers. With the cooperation and input of experienced gallery and exhibition lighting designers many things were discussed and considered. Not every work of art should have the same level of light or have the same lit effect. Was there a way of interchanging the reflector components, minimising the number of spotlight bodies required? Also, spotlights can be treated harshly so they needed to be particularly robust. Sometimes components fail mid exhibition build-up, was there a way of fixing the spotlights easily? Once aimed the spotlight should be locked in position. Dimming was a must.

With this information a design brief was outlined, which included the following features:

Light distribution: A choice of reflector beam angles

Spotlight flexibility: Reflectors had to be easily accessible and interchangeable without tools

Aiming angles: 360 degree horizontal, 0-90 degree vertical. With a stout, easily gripped, tilt angle lock

Light level control: Integral dimming control gear with an on-board dimmer and rotary switch

Repairable: A fixture that was simple to take apart with the internal components accessible and easy to change

Robustness: The main body was to be cast metal of graspable proportions

The original Baltic was designed for low voltage tungsten halogen capsule lamps. Now, with the advances of solid state technology the Baltic spotlight has all the advantages that LEDs can offer.

The Baltic spotlight was named after the first gallery it was specified for, the Baltic Gallery, Gateshead. Since then the Baltic has lit many galleries and exhibitions.

Some Baltic LED projects:

The Beaney House of Art and
Knowledge, Canterbury
Tate Modern
Tate Britain
Nottingham Castle Museum
National Portrait Gallery, London
Kirkby Suite, Liverpool
The Courtauld Gallery
Open Eye Gallery, Liverpool
De Vuyst Gallery, Belgium

Ikon Gallery, Birmingham
Max Hetzler Gallery, Germany
Tate Modern New Extension
Some Baltic TH Projects:
Derby Museum & Art Gallery
Arts Council England
The Baltic, Gateshead
Compton Verney
The Courtauld, London
Grundy Art Gallery, Blackpool
Karsten Schubert, London

Leeds Art Gallery
Moderna Museet, Stockholm
National portrait Gallery, London
Museo Nacional de Bellas Artes,
Santiago, Chile
Plymouth City Museum
Roemer und Pelizaeus-Museum,
Hildesheim
The White Cube, London
Timothy Taylor Gallery
Yeovil Art Gallery

DESIGN FEATURES

- 360 degree rotation
- Lockable vertical tilt angle
- Adjustment lever
- Integral 1-10v dimmable driver
- Rotary on-board dimmer
- Low and High output LED
- Xicato remote phosphor module
- Choice of colour appearance (colour temperature) - K
- Choice of colour rendering - Ra
- Designed to withstand heavy use and regular positioning
- Robust aluminium construction
- Cast aluminium housing
- Integral heat sink
- Interchangeable Reflectors
- All lens/reflector combinations give a smooth beam pattern and soft graduation and no edge effect
- A Eutrac 3 circuit adaptor is supplied as standard. Other track adaptors can be supplied on request



BALTIC X Construction detail for Xicato LED

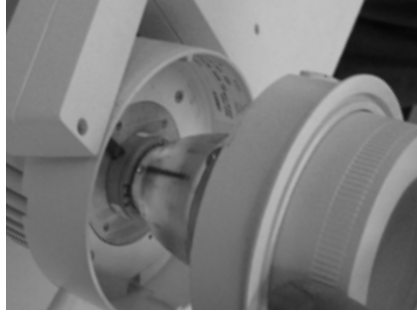
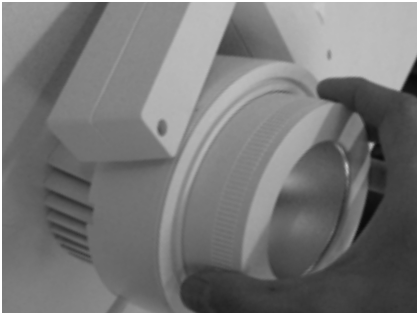

Baltic X - Method of changing the XTM reflectors

- Twist off reflector holder
- Remove existing reflector
- Push in alternative reflector
- Replace reflector holder

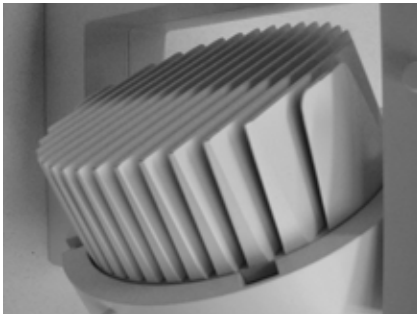

- Robust aluminium construction
- Cast aluminium housing
- Engineered heat sink to ensure cool operation of the light engine

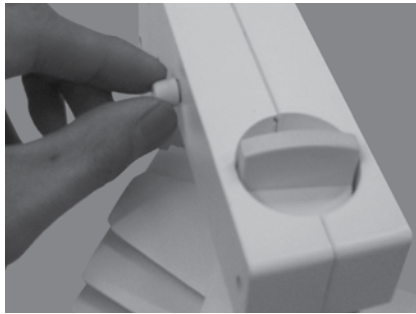

- Rotary on-board dimmer
- Integral 1-10v dimmable driver

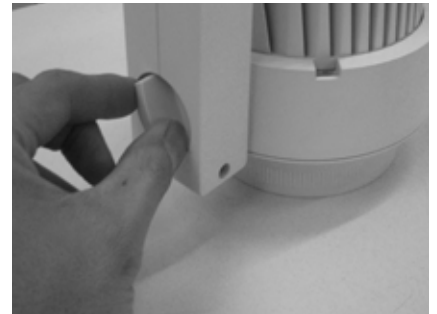

- Tilt angle locking device



BALTIC X

XICATO

Baltic X adjustable LED spotlight with Xicato LED light engine, interchangeable reflectors, integral 1-10v dimmable driver, rotary on-board dimmer and finished white (RAL 9010). Suitable for track mounting, universal 3 circuit type adaptor comes as standard. IP20.

To specify Baltic X both the Product Number and the Engine number are needed. Choose the required Series, Colour Temperature (K) and Colour Rendering Index (CRI - Ra). Then choose the reflector beam angle.

Reflector holder Type A comes as part of the body assembly and has interchangeable reflectors as shown. One reflector comes with the spotlight and is the clients choice. Additional reflectors can be ordered separately.

Example:

D1400/20A210 plus D5500 is Baltic X Standard series, 2700K, Ra80 with 24° medium beam reflector.

D1500/20B510 plus D5800 is Baltic X Artist series, 4000K, Ra95 with 80° washer beam reflector.

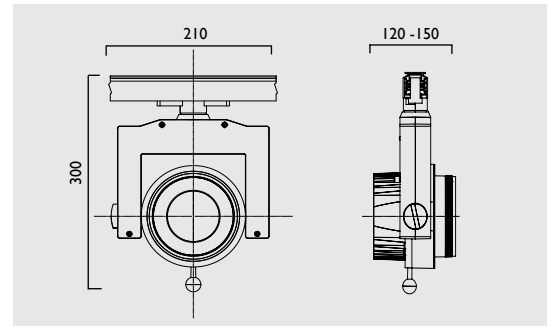

XTM Standard Series ≥ Ra80

2 step MacAdam, 2000 lumens, 19.5W

Product and Engine Number	Colour Temperature
D1400 / 20A210	2700K
D1400 / 20A310	3000K
D1400 / 20A410	3500K
D1400 / 20A510	4000K

XTM Artist Series ≥ Ra95

2 step MacAdam, 2000 lumens, 26.4W

Product and Engine Number	Colour Temperature
D1500 / 20B210	2700K
D1500 / 20B310	3000K
D1500 / 20B410	3500K
D1500 / 20B510	4000K

XTM Vibrant Series ≥ Ra80

2 step MacAdam, 2000 lumens, 19.5W

Product and Engine Number	Colour Temperature
D1600 / 20C310	3000K

XTM Vibrant Series ≥ Ra95

2 step MacAdam, 2000 lumens, 26.4W

Product and Engine Number	Colour Temperature
D1700 / 20D310	3000K

Reflector holder Type A



Reflectors



Medium
XTM LED - D5500



Wide
XTM LED - D5600



Flood
XTM LED - D5700

Photometric data for XTM LEDs

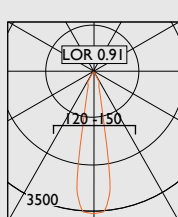

Lux/Klms	
1m	0.42 3393
2m	0.84 848
3m	1.27 377
4m	1.69 212

24° Beam diameter to 50% of E max

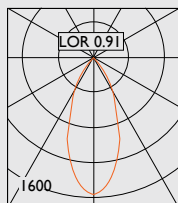

Lux/Klms	
1m	0.76 1557
2m	1.53 389
3m	2.29 173
4m	3.06 97

42° Beam diameter to 50% of E max

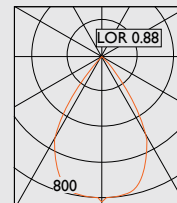

Lux/Klms	
1m	1.32 834
2m	2.64 417
3m	3.96 92
4m	5.28 52

67° Beam diameter to 50% of E max

Reflector holder Type B complete with reflector



Narrow
XTM LED - D5400

Photometric data for XTM LEDs

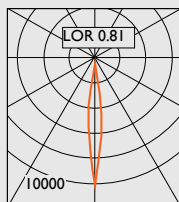

Lux/Klms	
1m	1.88 5584
2m	2.07 1396
3m	2.76 620
4m	3.45 349

10° Beam diameter to 50% of E max

Reflector holder Type C complete with reflector



Washer
XTM LED - D5800

Photometric data for XTM LEDs

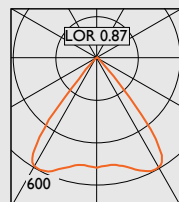

Lux/Klms	
1m	0.72 520
2m	1.45 260
3m	2.17 57
4m	2.90 32

80° Beam diameter to 50% of E max



Attachments

Product Description No

D3700 Barn Doors

Barn Doors D3700, only suitable for reflector holder Type A

IKON LED WASHLIGHT



IKON LED WASHLIGHT is a multi-solution lighting tool that will meet the needs of any gallery or exhibition space. It has been specially developed to achieve these requirements, providing superb quality and controlled light within a practical design format.

IKON LED is named after Ikon, the internationally acclaimed contemporary art gallery located in Birmingham. With ever changing exhibitions, the Ikon team were in need of a lighting product that was multi-functional and complimented the DAL BALTIC spotlights they were already using. A design brief was formulated: LED, dimmable, choice of colour appearance, high specification colour rendering, even light distribution and, crucially to overcome the introduction of harsh shadows as found when other LED washlights on the market were trialled. LED From this the IKON LED was developed.

Today, with the evolution of solid state technology and progressive product design an LED light source can be utilised to provide stable white light with excellent colour appearance and rendering, offering long life and minimal energy consumption.



All photographs by Handover Agency featuring exhibitions of work by Käthe Kollwitz and Sofia Hultén ©Ikon Gallery

PRODUCT FEATURES



Lockable angle adjustment



Rotary dimmer control



Lockable spill shield



ON-OFF and lamp colour switch option

Light Source: High quality LEDs
 Colour Rendering: Excellent CRI > 95
 Colour Temperature: Dual model, switchable 3000°K or 4000°K
 Coming soon 3000°K only and 4000°K only
 LED operation: Wired in parallel to allow highest output at the coolest temperature, ensuring correct LED operating conditions
 Longevity: 50,000 hrs L80
 Light Control: Smooth dimming down to 5% is achieved by a rotary control
 Construction: Fabricated steel and extruded aluminium construction
 Finish: White RAL 9010
 Optical Performance: Opalised membrane diffuses the LED light and controls the distribution resulting in an even distribution and appearance
 Glare control: An adjustable and lockable baffle / spill shield
 Energy (LED initial): >100 lms/W
 Construction: IP20 (dry interior use)
 Mounting: 2 x 3 Circuit Eutrac adapters
 Electrical Supply: 230v 50Hz
 Manufacture: Made in the UK

Product No	Length	Dual Switch	
L7401	600mm	3000K or 4000K	IP20

LED Specification				Ra<95
Colour Temp	Qty LED	Power Typically	Total Lumens	mA
3000K	5	6 - 27W	2,700	700
4000K	6	6 - 27W	3,100	700

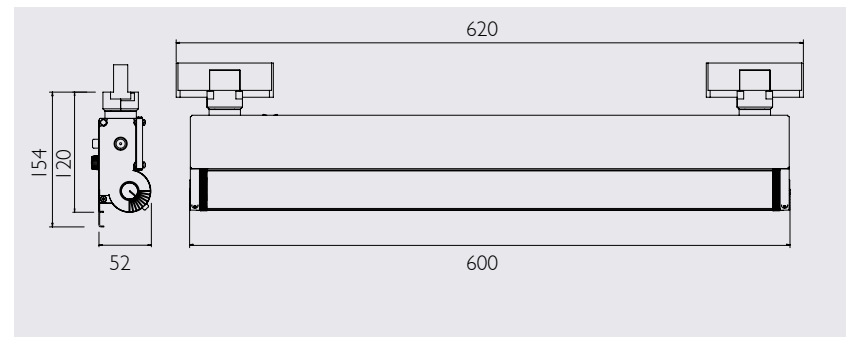

DISPLAY LIGHTING AND VISUAL EFFECTS

There are many things to consider when lighting paintings or displays, not just the amount of light, (as discussed in the section: Conservation) but also the type of object and how it is to be exhibited. The amount of light needed to make a noticeable, significant or a dramatic difference will depend on the surrounding, ambient level of light. A candle flame will look bright and illuminate the surroundings in a darkened room but will be barely perceptible in a bright, day lit environment. Also, the colour and reflective properties of the object will affect its perceived brightness (luminance).

Guide to lighting ratios for highlighting objects.

Object illuminance : ambient/background lighting

- 2:1 A perceptible difference
- 5:1 Distinct and noticeable difference
- 15:1 Dramatic and strong effect

The photographs illustrate, simply, how the angle of light can reveal or hide the form of an object or add interest. The first four show the wall behind the cash register is white and preferentially lit in different ways.

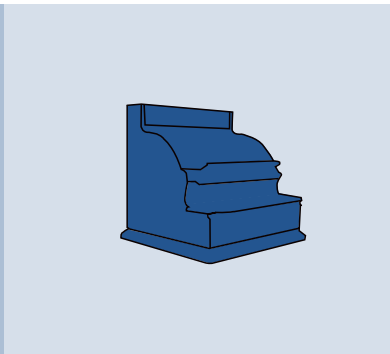

An even array of wallwashers provides the ambient lighting by reflecting light from the white wall behind with a small amount of incidental light illuminating the cash register. The eye is drawn more to the wall than to object which appears brown and flat.

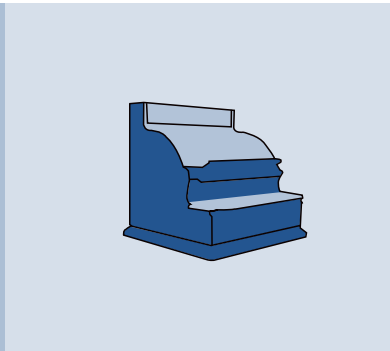

The ambient lighting is created by high level wall scalloping with spill light hitting the top of the cash register revealing the texture, and adding more interest.

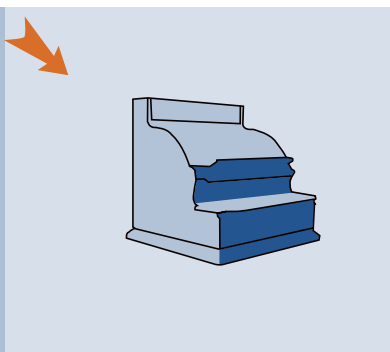

The ambient lighting is created by the same wall scalloping and spill light. More detail is revealed with the addition of a 24 degree beam Baltic spotlight lighting from the left. More texture is revealed, also sparkle. It also adds a shadow to the display.

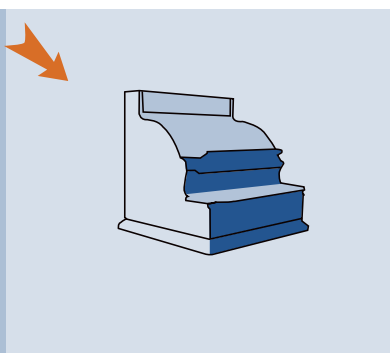

If the distribution of the Baltic spotlight is changed to a 12 degree beam the light intensity is higher. More detail is revealed but is also less subtle. The shadow becomes sharper.

The lit effect of the object is also influenced by the surrounding reflective surfaces. With the back ground changed from white to black and no preferential wall lighting the viewer is drawn more immediately to the cash register. Also, the plinth is white, and reflects light back onto the object. Four simple examples of how the direction of light can reveal the cash register's shape, detail and construction are presented. The beam angle is 24 degrees.

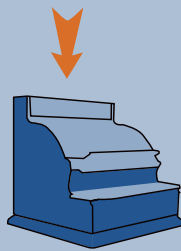

A single spotlight is positioned directly above, pointing straight down, adds drama by putting the side into shadow. The side becomes a silhouette, emphasising its form.

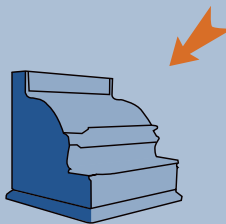

The spotlight is now to the right hand side, at approximately 45 degrees, and slightly in front. It now grazes light across the top the object, which flattens the decorative detail. However, the tabs within the cash register's glass mechanism are now revealed. Much of the side is still in silhouette.

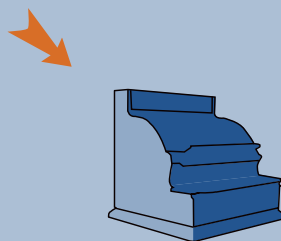

The spotlight is now positioned on the left side. It lights the top and side, revealing more of the intricate side detail, but loosing the previously revealed tabs. Perhaps reducing the overall interest.

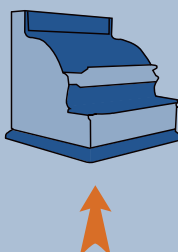

This time the cash register is lit from below. Perhaps not an obvious or easy thing to do but it creates a lot of drama. With much of the object in shade it is the detailed shadow rising behind that is interesting and intriguing.



The Heal's Building,
Tottenham Court Road/Alfred Mews, London
Building Services Consultant: Cundall
Architects: John McAslan + Partners
Photograph: Courtesy of LUX Magazine

The office areas of this recently refurbished Grade II listed building are part of the famous Heal's furniture store. Interestingly, nearly one hundred years ago, Heal's used horse and cart delivery vehicles. The new reception space once housed the areas which were used to bed, feed and water the horses.

AMBIANCE XI00 downlighters were used extensively throughout the project, resulting in the energy used, together with its control system, to exceed the current Building Regulations Part L limits by 20 per cent.

EMERGENCY MODULES AND EXIT SIGNS

DAL offers a selection of emergency lighting products. WAYLIGHT 3 is a single point, self contained, stand alone emergency luminaire and available as recessed or surface mounted. Also available are LED EXIT signs.

Standard non-emergency luminaires can be supplied with maintained, self contained emergency control gear to change over to emergency mode in the event of mains failure.



WAYLIGHT 3 EMERGENCY LIGHTING

Due to Building Regulations, the Fire Precautions Act, and the Health and Safety at Work Act it is necessary to provide suitable means of escape from a building in the event of an emergency, therefore, it is essential to provide enough light. All emergency lighting in the UK has to be designed in accordance with BS5266-1 Emergency Lighting: Code of practice for the emergency escape lighting of premises. There are several ways in which to incorporate emergency lighting. It can be maintained or non-maintained in self contained stand alone units, or as a conversion.

WAYLIGHT 3 are single point, self contained stand alone emergency lighting products. With a three hour emergency pack designed to pass through a 40mm diameter cut out or be surface mounted, providing a flexible solution. All WAYLIGHT 3 units contain a Bi-Colour LED indicator for green charge healthy and red self test function and can be used as part of a maintained or non-maintained system.

All these emergency lighting products are designed to meet the requirements of BS EN 61347-2-7, BS EN 60598-2-22. Most Designed Architectural Lighting downlighters are also available as emergency lighting conversions, details are shown in the section Emergency Lighting Components.

WAYLIGHT 3

WAYLIGHT 3 constant current 110° wide beam angle, 700mA 3W white LED. Complete with charge LED. Designed to comply with all of the requirements of BS EN 60598-2-22.



Product No	Beam	Output	IP
D0190	110°	194 lumens	IP20

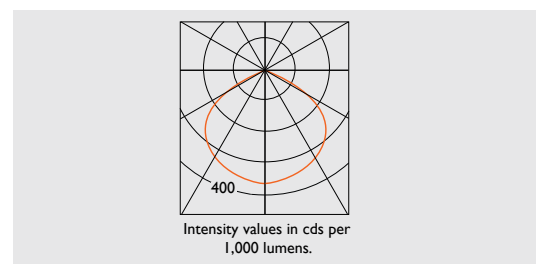
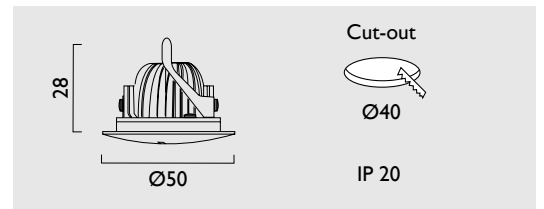

WAYLIGHT 3 OPEN AREA LENS

WAYLIGHT 3 constant current 110° wide beam angle with open area lens, 700mA 3W white LED.

Complete with charge LED.

Designed to comply with all of the requirements of BS EN 60598-2-22.

Product No	Output	IP
D0390	207 lumens	IP44

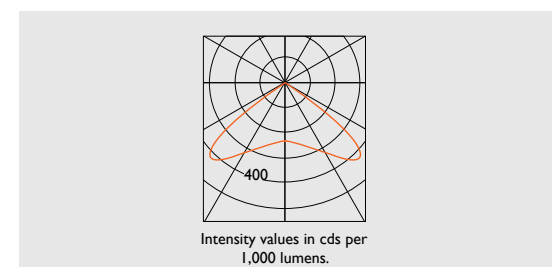
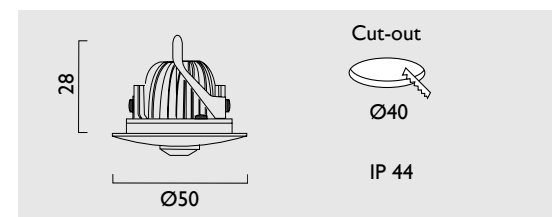

WAYLIGHT 3 CORRIDOR LENS

WAYLIGHT 3 constant current 110° wide beam angle with corridor lens, 700mA 3W white LED.

Complete with charge LED.

Designed to comply with all of the requirements of BS EN 60598-2-22.

Product No	Output	IP
D0590	197 lumens	IP44

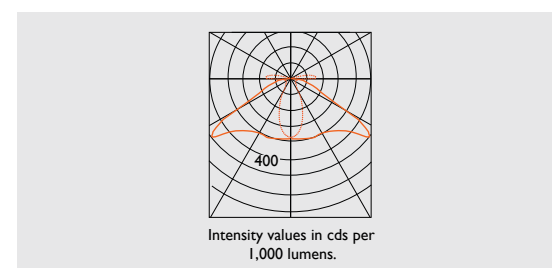
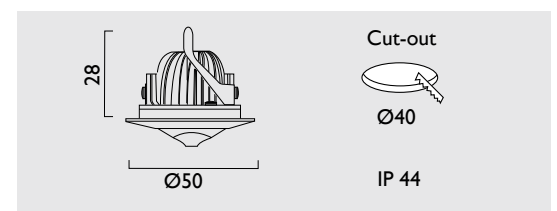

WAYLIGHT 3 ROUND SURFACE

WAYLIGHT 3 constant current, 3W white LED contained in a circular, ceiling mounted unit finished white. Complete with charge LED.
Designed to comply with all of the requirements of BS EN 60598-2-22.

Product No	Beam	Output	IP
WAYLIGHT 3 ROUND SURFACE D7090	110°	194 lumens	IP20
WAYLIGHT 3 OPEN AREA LENS D7190		207 lumens	IP44
WAYLIGHT 3 CORRIDOR LENS D7290		197 lumens	IP44

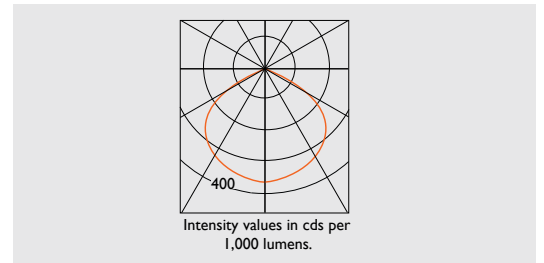
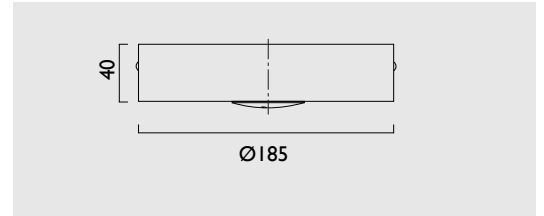

OPEN AREA LENS

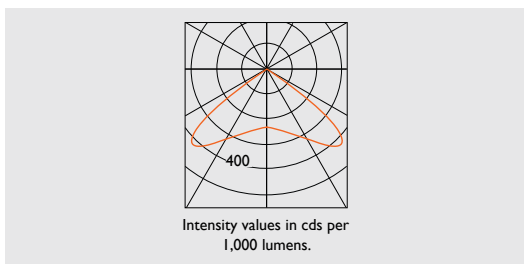

CORRIDOR LENS

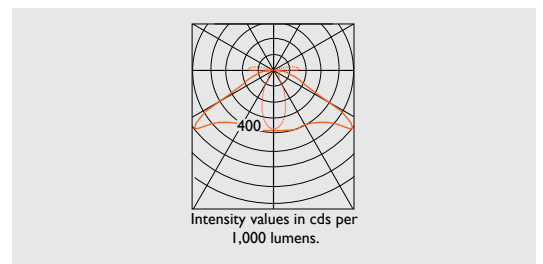
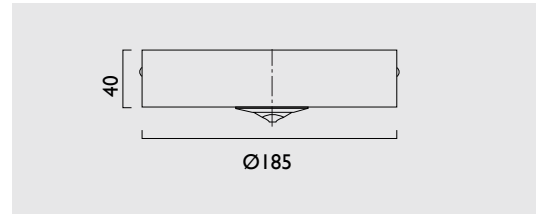

WAYLIGHT 3 SQUARE SURFACE

WAYLIGHT 3 constant current, 110 degree wide beam, 700mA 3W white LED contained in a square, ceiling mounted unit finished white.

Complete with charge LED.

Designed to comply with all of the requirements of BS EN 60598-2-22.

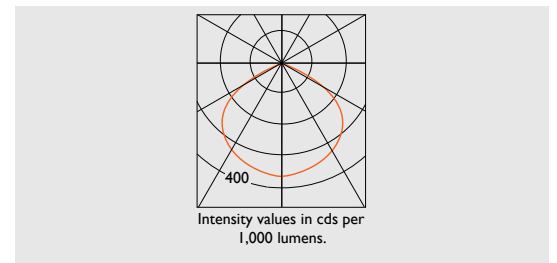
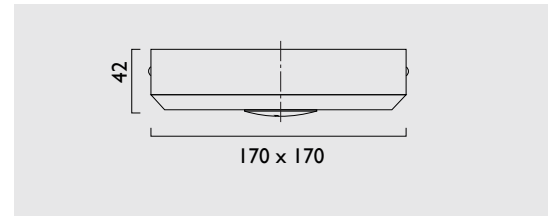

Product No	Beam	Output	IP
WAYLIGHT 3 SQUARE SURFACE D7390	110°	194 lumens	IP20
WAYLIGHT 3 OPEN AREA LENS D7490		207 lumens	IP44
WAYLIGHT 3 CORRIDOR LENS D7590		197 lumens	IP44

OPEN AREA LENS

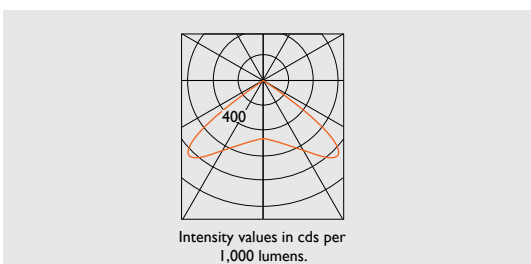
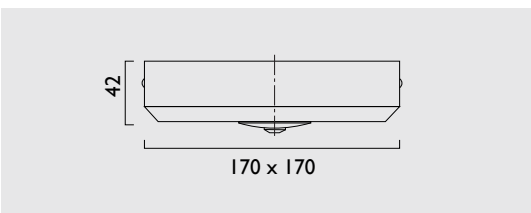

CORRIDOR LENS

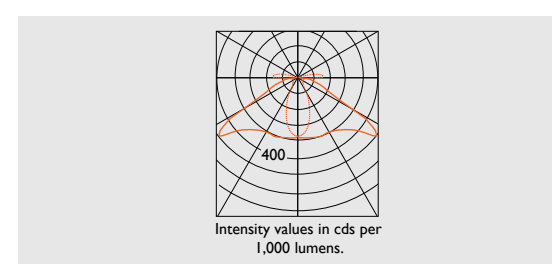
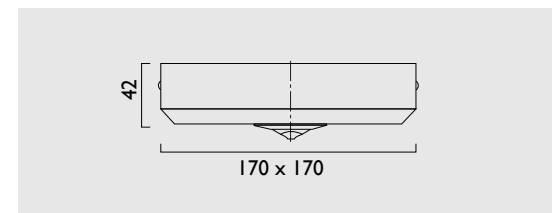

LEDEX LED EXIT SIGNS

Any point on an escape route, or leading to it, must have an EXIT sign, so there is no doubt about the direction of travel. Illuminated signs have twice the viewing distance compared to sign boards and Designed Architectural Lighting offer a complete range of illuminated LED EXIT signs. Using high efficiency white LEDs with 50,000 hours life, all signs provide a 3 hour maintained operation with quick re-charge.

The LEDEX range has a selection of mounting options: recessed, surface, pendant or wall mounting. There is a choice of clear acrylic legends: up, down, left and right, which will not discolour over time within normal operation. All products are built to the highest standard and comply with BS EN60598.2.22 Luminaires for emergency lighting.

Design Features:

Frame constructed in high quality aluminium extrusion finished in white or grey

Easily inserted sign panel

Specially silk-screened light conducting panel for high clarity

High luminance > 500cd/m²

Uniform illumination

DALI addressable

LEDs powered alternately ensuring the sign will lit

LEDEX General Specification:

Operation: Non-maintained, maintained or switched maintained

Source: 10 x 3 chip white LEDs

Battery: 6.4V 1.5Ah Li-Fe

Charge current: 150mA nominal

Recharge period: 24 hours (14 hrs for 1 hr duration)

Input voltage: 230Volt +/-10% ~ 50 Hz

Power: 4.8W / 8.0VA

DIRECTION SIGNS

/suffix	Legend	Direction
/ECAR	EC Format	Arrow Right
/ECAL	EC Format	Arrow Left
/ECAD	EC Format	Arrow Down
/ISOAR	ISO Format	Arrow Right
/ISOAL	ISO Format	Arrow Left
/ISOAU	ISO Format	Arrow Up

LEDEX S

LEDEX S wall mounted body finished white or grey. To specify choose body colour and add direction sign panel



Product No	Mounting Type	Finish	IP
D8000	Surface Wall Mounted	White	IP20
D8100	Surface Wall Mounted	Grey	IP20

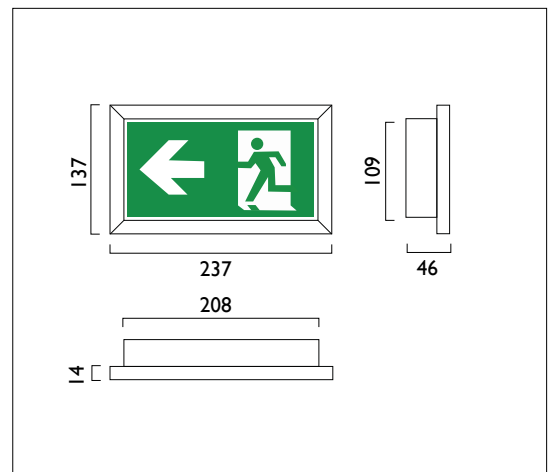

LEDEX R

LEDEX R ceiling recessed body, finished white or grey. To specify chose body colour and add direction sign panel.

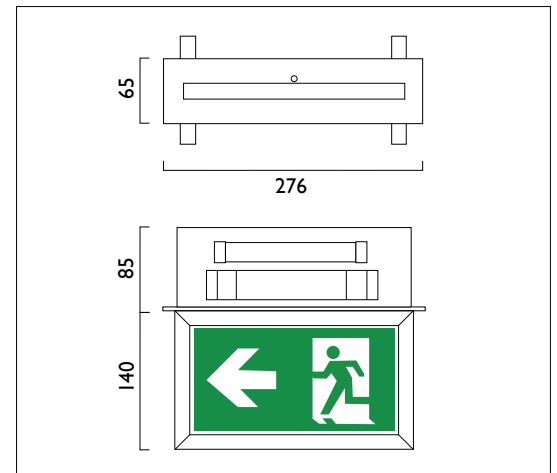

Product No	Mounting Type	Finish	IP
D8200	Ceiling Recessed	White	IP20
D8300	Ceiling Recessed	Grey	IP20
/DS	Double Sided Legend		

LEDEX SP

LEDEX S suspended body, finished white or grey. To specify chose body colour, whether the sign is to be double sided and add direction sign panel suffix.

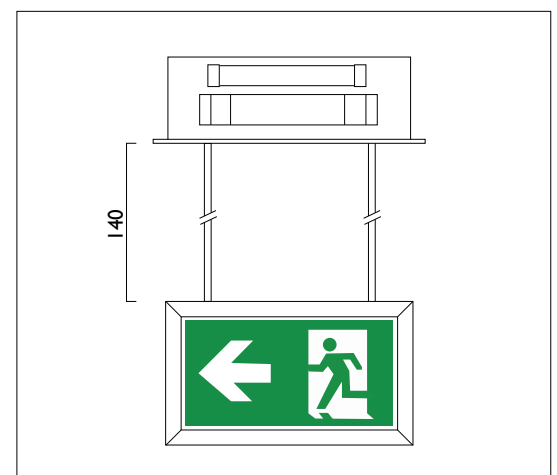

Product No	Mounting Type	Finish	IP
D8400	Rod Suspension	White	IP20
D8500	Rod Suspension	Grey	IP20
D8600	Wire Suspension	White	IP20
D8700	Wire Suspension	Grey	IP20
/DS	Double Sided Legend		

EMERGENCY LIGHTING COMPONENTS



Maintained Emergency Pack
For Xicato LED Module

Due to Building Regulations, the Fire Precautions Act, and the Health and Safety at Work Act it is necessary to provide suitable means of escape from a building in the event of an emergency. Therefore an essential element is to provide enough light for escape. Most of Designed Architectural Lighting luminaires are available as emergency versions and are classed as 'self contained three hour duration' which meet the requirements of EN 60598-1, EN 60598-2.22 and BS5266.

LED luminaires are generally operated on a maintained basis, where the LED is on at all times, whether being operated normally from the mains supply or from self contained emergency control gear. To specify add the appropriate suffix to the standard catalogue number. Please refer to the Emergency Lighting Components Table below.

For luminaires with small apertures reduced size versions of emergency pack maybe available. A green battery charging LED is fitted to the luminaire ceiling trim or mounted adjacent to the luminaire.

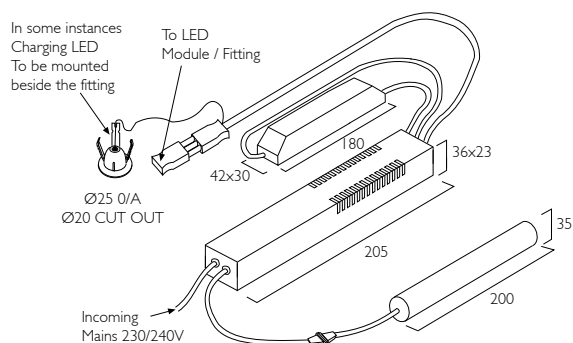

DOES NOT INCLUDE ANY DALI MONITORING DEVICE

Xicato LED Module	Lumens	Lumen Output in Emergency
Standard XTM	965	193
	1300	185
	2000	285
	3000	285
	4000	285

SELF TESTING AND OTHER EMERGENCY SYSTEMS

There are components available for the remote testing of the integrity of an emergency lighting system. Most can be incorporated with DAL products.

For other emergency lighting specification such as Static Inverter, Central Battery System or Self Test, please contact us with your requirements.

CONSERVATION



There is much to know and consider when planning a lighting layout. Although some of the lighting techniques used for retail displays are similar to those used in galleries or museums, there are some major differences that have to be addressed.

When considering what sort of light and how much light to use it is the conservation of the artworks and antiquities that should be the prime consideration. The deterioration of paintings and fugitive artworks is affected by a number of environmental factors including ultra-violet radiation, visible radiation and infra-red radiation. The extent of damage caused by a particular light source to an exhibit of given sensitivity depends on three main factors: the amount of light received by the painting (illuminance); the length of time it's exposed to light; the spectral distribution of the light source, which ranges from infrared (heat) to ultraviolet (fabric and skin damaging radiation).

There are currently considered to be four classifications for exhibits depending on the material and its level of responsivity (sensitivity) to light. Highly responsivity objects, moderate responsivity objects, low responsivity objects and irresponsive objects. For each classification there is a recommended illuminance and the amount of hours it is exposed over a year. For fuller explanations and recommendations there are several reference books and guides, in particular please refer to the CIBSE/Society of Light and Lighting - Lighting for Museums and Art Galleries, L.G.8.

LEDs are now of a high enough quality to provide a good solution. They are free of ultra violet radiation and very low infra-red radiation. They do, like all light sources, generate heat as energy but not in the form of spectral radiation. Also, LEDs have colour constancy when dimmed, unlike tungsten halogen.

ENERGY USE



Energy comparisons

It is usual to see the major selling point of LEDs being energy saving. As an example, we can compare low voltage tungsten halogen, the traditional light source for spotlighting in galleries and museums, with Xicato and GE Infusion LEDs.

Using the latest figures and the most significant information it is easy to see an immediate reduction in energy.

Lamp Type	Lumen Output (Flux)	Power Consumption (W)	Efficacy (lms/W)
12V Tungsten Halogen QT12	1600	75	21
HIT-TC Metal Halide	1700	20	85
LED Xicato Artist Series	2000	26.4	76
LED Xicato Standard Series	2000	19.5	102

The table is a simple illustration using figures at the time of print.



Project: London Designer Outlet, Wembley Park
Architect: Leslie Jones Architect
M&E Engineer:
Foreman Roberts Consulting Engineers
Electrical Contractor: AXIS M+E UK Ltd

Anyone who has attended a match or concert at the Millennium Stadium or the Arena could not fail to be attracted towards the bright and colourful lighting at the LDO.

DAL designed the curved, colour changing LED system mounted in the domes. The LED channel, mounted round the edge, reflects light into the domes which appear to float in the ceiling. Controlled by DMX, the Domes are one part of the lighting equipment used to create a dynamic and vibrant backdrop to the stores and restaurants.

CUSTOM PROJECTS

Alongside the standard range of luminaires DAL designs and manufactures custom luminaires and has an extensive portfolio of work, some of which are shown here.



The Ancell Library, London

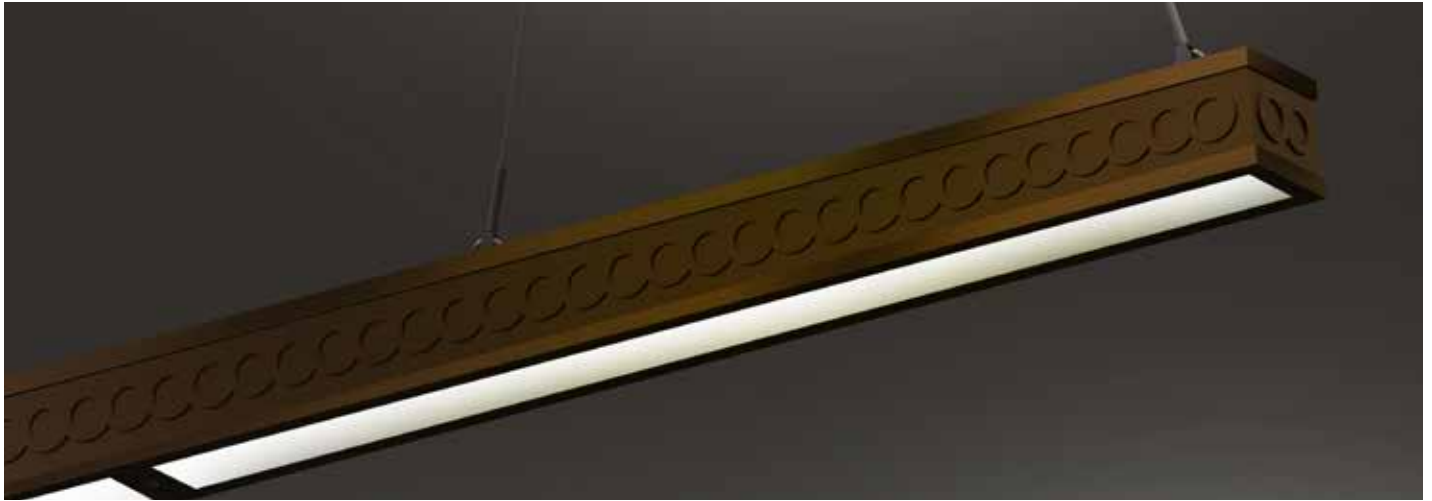

The Ancell Library, London, FCO
Consulting Engineer: WSP

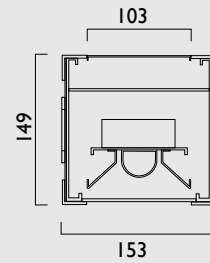

The Foreign Office Library was formally founded in 1801, with the appointment of Richard Ancell as its first librarian, but its functions and collection go back much earlier. The historical library collection of the Foreign and Commonwealth Office (FCO) comprises some 80,000 volumes of books, pamphlets, reports, typescripts and manuscript with a date range from the early 16th century to the present day.

DAL were delighted work on this prestigious project and be part of its history. Addressing the historical sensitivity and architectural features of the building, the custom LED luminaires were hand finished with rolled brass trim and laser cut circular embellishment.

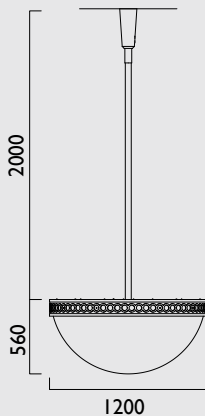

Masterpieces of Chinese Painting, the V&A



Masterpieces of Chinese Art, V&A
Lighting Specialist: Lightwaves Ltd
Architect: Stanton Williams

A selection of the finest examples of Chinese painting dating from the 8th to the 20th Century, were brought together in one exhibition at the Victoria and Albert Museum. Exhibited in specially designed cases DAL worked with the team through several prototype stages. The aim: to wash light the exhibits evenly with the highest quality linear LED available, whilst obscuring the light source from all viewing angles. A complex reflector arrangement was developed to achieve this.

Picture Light



Private Art Collection
Lighting Specialist: Lightwaves

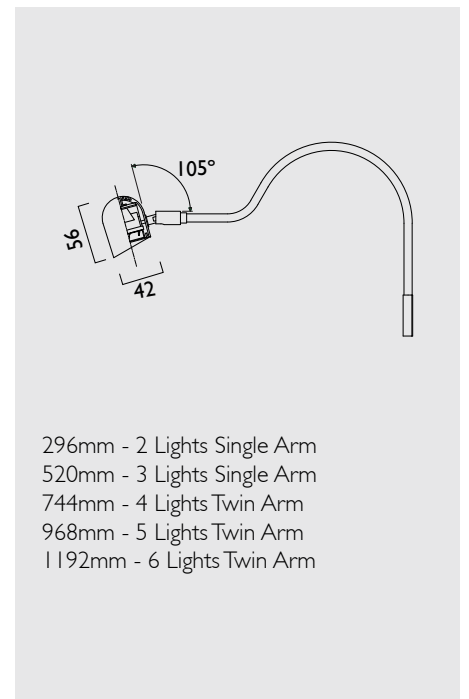

- 296mm - 2 Lights Single Arm
- 520mm - 3 Lights Single Arm
- 744mm - 4 Lights Twin Arm
- 968mm - 5 Lights Twin Arm
- 1192mm - 6 Lights Twin Arm

The bronze finished PICTURE LIGHT was developed for a prestigious client to light their fine art, a wide-ranging collection of portraits and work by major British artists. Comprising a complex array of lenses and cut-off baffles mounted within an adjustable luminaire head, the light can be constructed in different lengths to accommodate many sizes of picture. The PICTURE LIGHT included an integral driver with on-board rotary dimmer. The LEDs were 3000K, Ra >98.

Bush House, Aldwych Quarter, London

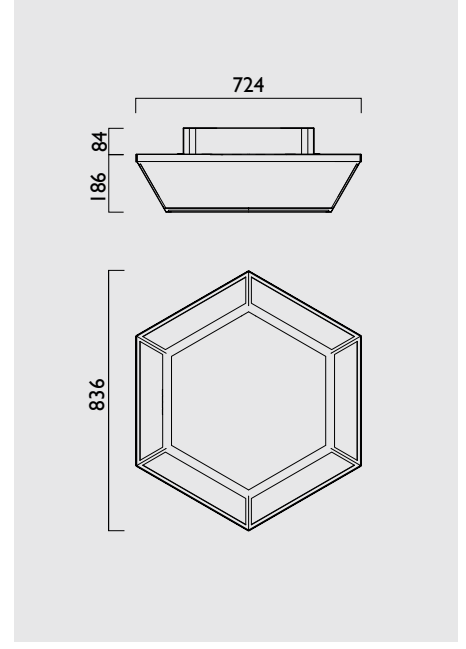

Consulting Engineer: Hilson Moran
 M&E Contractor: Skanska Architects: John Robertson Associates

The former home of the BBC World Service is a Grade II listed building and part of one of London's largest refurbishment projects known as the Aldwych Quarter. The historic building was originally owned by a collective of American individuals and companies who appointed architect Harvey Wiley Corbett to design the building.

Built from Portland stone, Bush House was allegedly declared the "most expensive building in the world" in 1929.

The recent project included not only the conservation and restoration of the historic façade but also the interior luminaires, a selection of art deco style wall and ceiling lights. These were in varying states of disrepair and DAL was contracted to upgrade and refurbish them to the highest quality.

White City, Baku, Azerbaijan

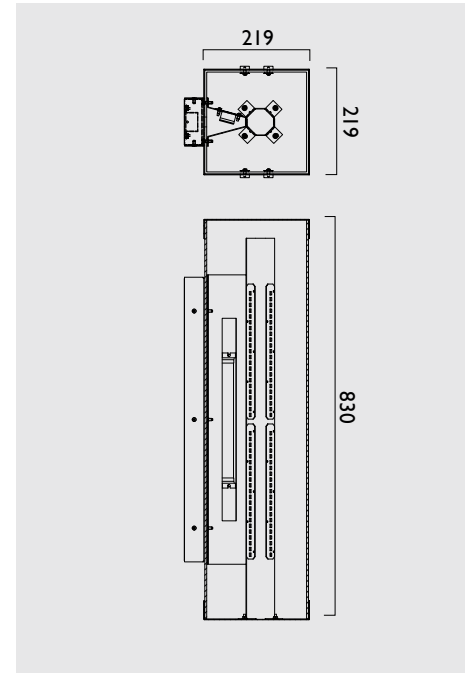

Baku White City Hotel, Baku
 Lighting Consultant: MBLD
 Construction Design and Development
 PASHA Construction

Baku, the capital of Azerbaijan, is a low-lying city on the edge of the Caspian Sea. The newly developed White City, to the south east, was once the heart of Azerbaijan's oil industry.

Wall mounted luminaires were required for the development. They had to have an even glow with uniform light distribution and detailed to IP54 exterior specification. The final design was developed with the team, resulting in an opal diffuser held in a metallic bronze frame with a decorative band feature. The warm white Ra > 80 LEDs provide general and even illumination and are dimmable.

London Designer Outlet, Wembley



Architect: Leslie Jones Architect
M&E Engineer:
Foreman Roberts Consulting Engineers
Electrical Contractor: AXIS M+E UK Ltd

The LDO retail and entertainment complex is part of the redevelopment of former industrial land close to Wembley Stadium, Wembley Park and Wembley Stadium stations. The 87-acre site continues to be developed with a substantial number of residential buildings being built beside Brent Civic Centre and Wembley Arena.

DAL provided a full package of standard and custom designed luminaires, including wall mounted square drum downlighter with integral control gear. Rated at IP54 they are finished RAL 7022 Umbra Grey

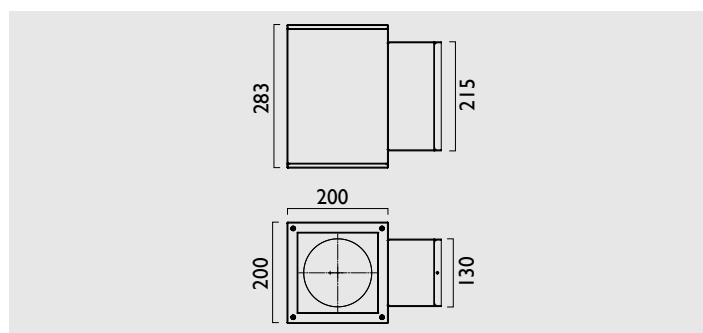

LED TECHNOLOGY

When artificial lighting and control systems are used to their fullest potential they can create healthy living and working environments. To this end, LEDs are a light source with which intelligent and dynamic installations can be created. LEDs also offer cost effective and energy efficient lighting for many applications, but like other light sources each type should be chosen on its own merits. For this reason DAL has chosen specific LED products to suit their luminaires.

The wide use of LEDs in interior lighting design has been hindered until recently by the poor quality of white light LEDs and their low light output. But now there have been significant advances in LED lighting technology, enabling DAL to develop linear lighting products with confidence.

With many years of experience in the design, development and manufacture of all types of luminaires DAL is a respected member of the lighting industry, affording them access to LED and control products from many specialist companies.

Therefore, DAL is not constrained to a single brand, and uses the most appropriate type of LED for the application.

Unlike many other lamps (compact fluorescent, HID, tungsten halogen) the luminaire, driver and LED components are not easily interchangeable with other manufacturers' products. This is because, for optimum performance of the LED, good heat management is essential; this ensures the correct operating characteristic of the LED. Conventional lamps emit most of their heat through radiation. LEDs transfer their heat by conduction, and if the heat is not adequately dispersed light output and life will be adversely affected. Various methods can be used to transfer heat and the most simple and reliable way is a well-designed heat sink (passive cooling).

LEDs can be easily controlled as part of energy management systems. DALI, SwitchDim and other dimming or lighting control systems are feasible with the appropriate driver.

In order to achieve the best lighting products DAL works with several major LED manufacturers.

For in depth LED product specification please contact us.

The information is correct at the time of printing and the products shown are specific to the DAL range.

Advantages of LEDs Include:

- Long life resulting in low maintenance costs
- Cool beams of light
- No ultraviolet
- Low infrared
- Mercury free / Lead free
- Low energy
- High luminous efficacy
- Colour stability
- Instant light
- High performance
- Precise optical control
- Emergency options
- Dimmable

LED information

LEDs (Light-emitting diodes) generate light using the special electronic properties of crystalline semiconductors and solid state technology.

As well as being free of Ultraviolet radiation, LEDs have very low Infrared radiation in the beam.

Because the thermal operation is crucial, the LED is supplied as an integral part of the DAL luminaire. LEDs are sometimes known as Light Engines, Pucks or Modules.

LED control gear is known as a Driver.

LED COLOUR TECHNOLOGY

Colour Temperature

Light and Colour is a huge topic, much bigger than can be explained here, but obviously it is a major characteristic of artificial light, with a lamp's colour temperature playing a major part in lighting design - how warm or cool an interior will appear - so, being informed about the colour properties of light sources, such as LEDs is important.

The colour temperature of all light sources, from candle light to daylight, is measured in units of absolute temperature - Kelvin (K), using the scientific laws of the black body radiator. But, because LED manufacturers produce different colours of white light by adding various phosphors to blue light LEDs, there is an allowable tolerance (+/-) and the colours are specified by correlated colour temperature (CCT).

The CIE 1931 x,y chromaticity space diagram illustrates where the black-body curve defines white light. It also shows the chromaticities of black body light sources of various temperatures and lines of constant Correlated Colour Temperature. The CCT is the colour temperature at a point on a black-body radiator (Planckian locus) which most closely matches the colour of the light emitted from the light source. The most commonly used colour temperatures in interior lighting design range from 2700K through to 4000K, with the lower number being warmest and the higher number being the coolest.

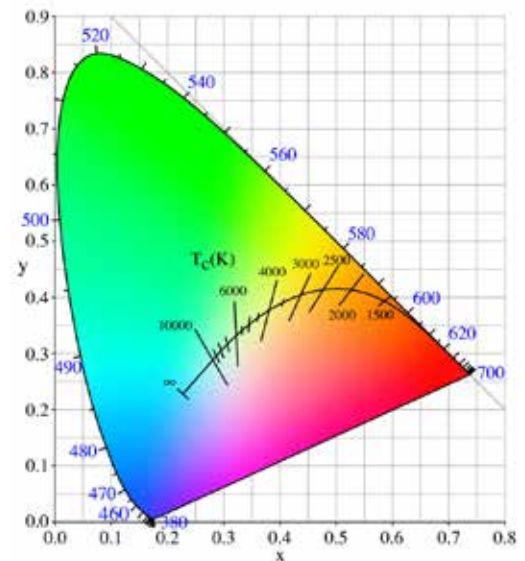

A CIE x,y chromaticity space diagram illustrates where the black body locus defines white light. It also shows black-body light sources of various temperatures and lines of constant correlated colour temperature.

Colour Rendering Index (CRI)

Just as significant as choosing an LED for its color appearance is its colour rendering properties, and CRI is an indicator of its ability to realistically reproduce the colour of an object.

The colour rendering properties of a light source are illustrated by its spectral distribution in the form of a curve. However, more commonly used is the CIE colour rendering index. This classifies how true a colour surface will appear when lit by an artificial light source. The higher the colour rendering index (on a scale of 0 to 100) of the source, the more accurate it is.

The CIE classifies colour rendering in two ways: Colour Rendering Groups 1- 4 and the general Colour Rendering Index $R_a \geq 20$ to ≥ 90 . These, however, are based on 8 pastel colours and do not take into account all 15 CIE test colours so closer reading of LED manufacturers' literature maybe needed.

Wherever accurate colour matching is required sources in Group 1A, $R_a \geq 90$ should be specified. When slightly less accuracy is needed Group 1B, $R_a \geq 80$ should be sufficient. It should be noted, with LEDs, as with other sources using phosphors, the higher the CRI luminance efficacy will be reduced.

MacAdam Ellipses

MacAdam ellipses are also quoted as method by which a specifier can ensure consistence in colour. MacAdam ellipses describe the colour distances on the x,y co-ordinates in the form of steps around target points. Again, this it to do with manufacturing tolerances and perceptible difference. These are certain target points on the CIE diagram, which lamp and LED manufacturers endeavour to meet. While industry standard LED binning structures allow for colour points in a 7 step MacAdam ellipse, it is recognised that this is too large a tolerance leading to perceptible colour variation between LEDs. An LED of 3 step MacAdam is considered very high quality and 2 steps even higher.

As an LED ages it can have colour shift, so if they are manufactured within a small MacAdam Step it is likely to keep to an imperceptible difference.

LED Life and Lumen Maintenance

During its operating life the amount of light from all light sources decreases. Calculated as a percentage of the original light output, the amount of light emitted from the source at a specific time in the future is referred to as its lumen maintenance.

In general, LEDs have better lumen maintenance than any other light source. It is usual to see quoted Lumen Maintenance figures of 80% (L80) or higher after 50,000 hours of use. However, good lumen maintenance and consistent colour are also dependent on the correct thermal operating conditions of the LED, so the correct heat sink and luminaire designs are fundamental.

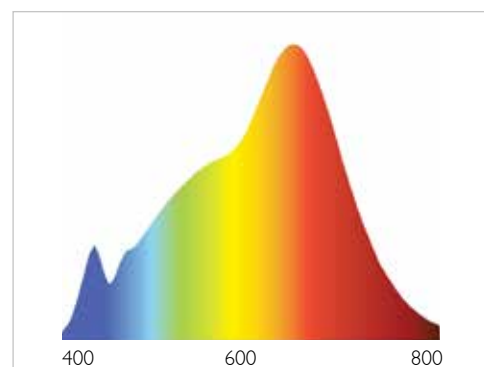

Typical spectral power distribution of a 3000K phosphor coated LED.

LIGHT ENGINES & DRIVERS

A driver is needed to operate every downlighter. The current (mA) of the driver determines the lumen output of the LED. The lumens of LEDs vary, depending on their colour temperature (K) and their colour rendering (CRI / Ra). Each driver is specific to the lumen output. This is why it is necessary to have so many product numbers.

It is to be noted that different colour appearances (K) of LEDs have slightly different lumens outputs. In order to simplify things, using various manufacturers figures DAL quotes mean average lumens for L and C products. The lumens quoted for X products are directly from the manufacturer.

DOWNLIGHTER PRODUCT CODES - EXPLAINED :

The product numbers are assigned using the following system:

Product No / Product Range

C0931

Range First 3 figures	Beam Angle°	Optic
	0 no option	0 None
	1 1-10°	1 Specular
	2 11-20°	2 Satin
	3 21-30°	3 Black
	4 31-40°	4 White
	5 41-50°	5 Gold
	6 51-60°	6 Bronze
	7 61-70°	7 Semi-Spec
	8 71-80°	8 Spectro
	9 81°+	

L and C COB LED Technology,

DRIVER CODES EXPLAINED :

Driver numbers are assigned using the following system:

Light Engine Options

100350

Engine Lumen	Colour Temp °K	Driver Protocol	Emerg Protocol
090 900 lumens	2 2700°k	0 Fixed	0 None
100 1000 lumens	3 3000°k	1 I-10V	E Emergency
120 1200 lumens	5 4000°k	3 DSI	
		5 DALI	
		7 Lead / Trail	
		9 Addressable	

Dimming, Control System (5th digit)

- 1 - I-10v
- 3 - DSI
- 5 - DALI
- 7 - Lead/trailing
- 9 - Addressable

XICATO DRIVER CODES -

EXPLAINED :

Driver numbers are assigned using the following system:

Light Engine Options

13^{LETTER}350

Engine Lumen	Colour Temp °K	Driver Protocol	Emerg Protocol
09A 965 lumens	2 2700°k	0 Fixed	0 None
13A 1300 lumens	3 3000°k	1 I-10V	E Emergency
14A 1490 lumens	4 3500°k	3 DSI	
20A 2000 lumens	5 4000°k	5 DALI	
30A 3000 lumens		7 Lead / Trail	
		9 Addressable	

XTM 19mm

- A - Standard Ra80
- B - Artist Ra95
- C - Vibrant Ra80
- D - Vibrant Ra95

COB Technology LEDs

>Ra80, Life 50,000 hrs

Typical Lumen Outputs and Current for

Standard operation, I-10v, DSI, DALI and Addressable protocols

Engine Options - ColourTemp (Kelvin)			Output (nominal lms)	Watts (W)	Efficacy (lms/w)	Current (mA)
Product Number: Cxxxx / Engine						
2700K	3000K	4000K				
090200	090300	090400	904	6.2	145	180
100200	100300	100400	1084	7.8	128	220
120200	120300	120400	1257	9.3	129	260

COB Technology LEDs

>Ra80, Life 50,000 hrs

Typical Lumen Outputs and Current for Leading / Trailing protocols

Engine Options - ColourTemp (Kelvin)			Output (nominal lms)	Watts (W)	Efficacy (lms/w)	Current (mA)
Product Number: Cxxxx / Engine						
2700K	3000K	4000K				
100270	100370	100470	1084	7	142	200

- Other COB LEDs are available on request. For example lower lumen outputs and >Ra90 / Ra97 products.
- Because LED technology continues to develop please check with us for the latest issue and generation products.
- Fittings are tested with Ra >80 LEDs at 30° C thermal ambient.
- COB = Chip On Board

LED downlighters are Class III and must be operated with a compatible driver. For this reason DAL supplies these, to the clients' control protocol specification, as part of the luminaire.

A driver is needed to operate and control every downlighter. The driver is specific to whether a control system is being used or not, and what type (Driver Protocol).

To ensure downlighter heights and ceilings are compatible on-site recess depths should be checked.

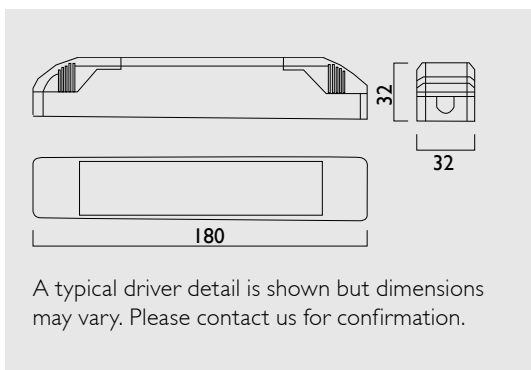

Xicato XTM 19mm LEDS

XTM 1300 (720-1300 lms), Standard Series >Ra80, Life 50,000 hrs

Engine Options - Colour Temp (K)				Output (lms)	Watts (W)	Efficacy (lms/w)	Current (mA)
Product Number: Cxxxx / Engine							
2700K	3000K	3500K	4000K				
07A200	07A300	07A400	07A500	720	4.5	160	350
09A200	09A300	09A400	09A500	965	6.6	146	500
13A200	13A300	13A400	13A500	1300	9.5	137	700

- Other Xicato LEDs are available on request. For example Ra98 Artist and Vibrant Series.

- XTM information maybe subject to change as Xicato LED technology advances. Please check with us for the latest developments.

XTM 2000 (1105-2000 lms), Standard Series >Ra80, Life 50,000 hrs

Engine Options - Colour Temp (K)				Output (lms)	Watts (W)	Efficacy (lms/w)	Current (mA)
Product Number: Cxxxx / Engine							
2700K	3000K	3500K	4000K				
11A200	11A300	11A400	11A500	1105	7.2	153	350
14A200	14A300	14A400	14A500	1490	10.6	141	500
20A200	20A300	20A400	20A500	2000	15.2	131	700

- XIM intelligent LED modules with integrated driver are available from Xicato. Please check with us for our latest product developments.

- All DAL XICATO remote phosphor LED downlighters can be supplied with the latest COB technology, as an alternative.

XTM 3000 (1585-3000 lms), Standard Series >Ra80, Life 50,000 hrs

Engine Options - Colour Temp (K)				Output (lms)	Watts (W)	Efficacy (lms/w)	Current (mA)
Product Number: Cxxxx / Engine							
2700K	3000K	3500K	4000K				
15A200	15A300	15A400	15A500	1585	11.6	137	500
21A200	21A300	21A400	21A500	2100	16.5	127	700
30A200	30A300	30A400	30A500	3000	25.7	117	1050

- 6000 lumen downlighters are in development. Please speak to us for the latest information.

- Fittings are tested with Ra >80 LEDs at 30° C thermal ambient.

XTM 4000 Standard and Vibrant Series >Ra80, Life 50,000 hrs

Engine Options - Colour Temp (K)				Output (lms)	Watts (W)	Efficacy (lms/w)	Current (mA)
Product Number: Cxxxx / Engine							
2700K	3000K	3500K	4000K				
40A200	40A300	40A400	40A500	4000	34.2	117	1400

Bluetooth Wireless Control Dimming and is possible with enabled drivers, enabling the control and management of LED luminaires via mobile devices

- (Apple or Android).
- Because LED technology continues to develop please check with us for the latest issue and generation products.

XTM 5000, Standard and Vibrant Series >Ra80, Life 50,000 hrs

Engine Options - Colour Temp (K)				Output (lms)	Watts (W)	Efficacy (lms/w)	Current (mA)
Product Number: Cxxxx / Engine							
2700K	3000K	3500K	4000K				
50A200	50A300	50A400	50A500	5000	41.8	120	1400

DOWNLIGHTER NUMBER INDEX

C0131 11	C0461 13	C1152 15	C2060 24	C7221 52	L7401 133	F0543 23	G0320 20
C0132 11	C0462 13	C1153 15	C2120 24	C7222 52	D6121 16	F0544 23	G0330 20
C0133 11	C0463 13	C1154 15	C2140 24	C7224 52	D6122 16	F0563 23	G0340 20
C0134 11	C0464 13	C1155 15	C2160 24	C7241 52	D6123 16	F0564 23	G0360 20
C0135 11	C0465 13	C1161 15	C2220 24	C7242 52	D6124 16	F0733 41	G0420 20
C0138 11	C0521 13	C1162 15	C2240 24	C7244 52	D6125 16	F0734 41	G0430 20
C0151 11	C0522 13	C1163 15	C2260 24	C7261 52	D6141 16	F0743 41	G0440 20
C0152 11	C0523 13	C1164 15	C2330 24	C7262 52	D6142 16	F0744 41	G0460 20
C0153 11	C0524 13	C1165 15	C2350 24	C7264 52	D6143 16	F1143 41	G0520 19
C0154 11	C0525 13	C1201 15	C2360 24	C7581 53	D6144 16	F1144 41	G0530 19
C0155 11	C0541 13	C1202 15	C2430 24	C7681 53	D6145 16	F1163 41	G0540 19
C0158 11	C0542 13	C1203 15	C2450 24	C7901 54	D6161 16	F1164 41	G0560 19
C0161 11	C0543 13	C1204 15	C2460 24	C8101 54	D6162 16	F1533 23	G0620 19
C0162 11	C0544 13	C1205 15	C2530 24	C8401 55	D6163 16	F1534 23	G0630 19
C0163 11	C0545 13	C1321 16	C2550 24	C8727 56	D6164 16	F1543 23	G0640 19
C0164 11	C0561 13	C1322 16	C2560 24	C8747 56	D6165 16	F1544 23	G0660 19
C0165 11	C0562 13	C1323 16	C2630 24	C8767 56	D6221 16	F2008 31	G0720 21
C0168 11	C0563 13	C1324 16	C2650 24	C8827 56	D6222 16	F2108 31	G0730 21
C0231 11	C0564 13	C1325 16	C2660 24	C8847 56	D6223 16	F2208 30	G0740 21
C0232 11	C0565 13	C1341 16	C2708 30	C8867 56	D6224 16	F3008 29	G0760 21
C0233 11	C0621 13	C1342 16	C2808 30	C8927 57	D6225 16	F3740 25	G0820 21
C0234 11	C0622 13	C1343 16	C2908 33	C8947 57	D6241 16	F3840 25	G0830 21
C0235 11	C0623 13	C1344 16	C3008 33	C8967 57	D6242 16	F4141 60	G0840 21
C0238 11	C0624 13	C1345 16	C3108 33	C9027 57	D6243 16	F4241 60	G0860 21
C0251 11	C0625 13	C1361 16	C3208 33	C9047 57	D6244 16	F4321 61	G1120 18
C0252 11	C0641 13	C1362 16	C3308 34	C9067 57	D6245 16	F4341 61	G1130 18
C0253 11	C0642 13	C1363 16	C3408 34	C9107 57	D6261 16	F4361 61	G1140 18
C0254 11	C0643 13	C1364 16	C3508 34	C9207 57	D6262 16	F4421 61	G1160 18
C0255 11	C0644 13	C1365 16	C3608 34	C9321 60	D6263 16	F4441 61	G1220 18
C0258 11	C0645 13	C1421 16	C3708 35	C9341 60	D6264 16	F4461 61	G1230 18
C0261 11	C0661 13	C1422 16	C3808 35	C9361 60	D6265 16	F4508 44	G1240 18
C0262 11	C0662 13	C1423 16	C3908 35	C9421 60	D7090 140	F4608 33	G1260 18
C0263 11	C0663 13	C1424 16	C4008 35	C9441 60	D7190 140	F4708 33	G1320 20
C0264 11	C0664 13	C1425 16	C4108 36	C9461 60	D7290 140	F4808 33	G1330 20
C0265 11	C0665 13	C1441 16	C4208 36	C9521 61	D7390 141	F4908 33	G1340 20
C0268 11	C0701 14	C1442 16	C4308 36	C9522 61	D7490 141	F5008 34	G1360 20
C0321 13	C0702 14	C1443 16	C4408 36	C9524 61	D7590 141	F5108 34	G1420 20
C0322 13	C0703 14	C1444 16	C4508 37	C9541 61	D8000 142	F5208 34	G1430 20
C0323 13	C0704 14	C1445 16	C4608 37	C9542 61	D8100 142	F5308 34	G1440 20
C0324 13	C0705 14	C1461 16	C4708 37	C9544 61	D8200 143	F5408 35	G1460 20
C0325 13	C0931 14	C1462 16	C4808 37	C9561 61	D8300 143	F5508 35	G2024 42
C0341 13	C0932 14	C1463 16	C4908 44	C9562 61	D8400 143	F5608 35	G2064 42
C0342 13	C0933 14	C1464 16	C5108 45	C9564 61	D8500 143	F5708 35	G2204 42
C0343 13	C0934 14	C1465 16	C5308 45	C9732 65	D8600 143	F5808 36	G2424 43
C0344 13	C0935 14	C1520 17	C5508 46	C9752 65	D8700 143	F5908 36	G2464 43
C0345 13	C0941 14	C1540 17	C5708 46	C9762 65	D9520 24	F6008 36	G4008 12
C0361 13	C0942 14	C1560 17	C5908 47	D0190 138	D9540 24	F6108 36	G5040 25
C0362 13	C0943 14	C1620 17	C6108 47	D0390 139	D9560 24	F6608 45	H0107 62
C0363 13	C0944 14	C1640 17	C6308 48	D0590 139	D9620 24	F6808 45	H0207 62
C0364 13	C0945 14	C1660 17	C6508 48	D0708 29	D9640 24	F7008 46	H0301 63
C0365 13	C0961 14	C1720 17	C6708 49	D0808 29	D9660 24	F7208 46	H0707 63
C0421 13	C0962 14	C1740 17	C6908 49	D1400 130	D9720 24	F7408 47	H0807 65
C0422 13	C0963 14	C1760 17	C7121 52	D1500 130	D9740 24	F7608 47	L1002 94
C0423 13	C0964 14	C1820 17	C7122 52	D1600 130	D9760 24	G0120 18	L1003 94
C0424 13	C0965 14	C1840 17	C7124 52	D1700 130	D9820 24	G0130 18	L1004 94
C0425 13	C1131 15	C1860 17	C7141 52	D3700 131	D9840 24	G0140 18	L1005 94
C0441 13	C1132 15	C1920 24	C7142 52	D5400 131	D9860 24	G0160 18	L1006 94
C0442 13	C1133 15	C1940 24	C7144 52	D5500 131	F0114 12	G0220 18	L1102 94
C0443 13	C1134 15	C1960 24	C7161 52	D5600 131	F0124 12	G0230 18	L1103 94
C0444 13	C1135 15	C2020 24	C7162 52	D5700 131	F0144 12	G0240 18	L1104 94
C0445 13	C1151 15	C2040 24	C7164 52	D5800 131	F0164 12	G0260 18	L1105 94

PRODUCT NUMBER INDEX

L1106 94	L1704 96	L2302 102	L2805 104	L3405 95	L4412 114	L7102 87	L8504 96
L1202 94	L1705 96	L2303 102	L2806 104	L3406 95	L4418 114	L8002 94	L8505 96
L1203 94	L1706 96	L2304 102	L2902 104	L3504 95	L4424 114	L8003 94	L8506 96
L1204 94	L1802 98	L2305 102	L2903 104	L3505 95	L4506 114	L8004 94	L8602 96
L1205 94	L1803 98	L2306 102	L2904 104	L3506 95	L4512 114	L8005 94	L8603 96
L1206 94	L1804 98	L2402 102	L2905 104	L3604 95	L4518 114	L8006 94	L8604 96
L1302 94	L1805 98	L2403 102	L2906 104	L3605 95	L4524 114	L8102 94	L8605 96
L1303 94	L1806 98	L2404 102	L3002 106	L3606 95	L4601 118	L8103 94	L8606 96
L1304 94	L1902 98	L2405 102	L3003 106	L3704 95	L4602 118	L8104 94	L8702 96
L1305 94	L1903 98	L2406 102	L3004 106	L3705 95	L4603 118	L8105 94	L8703 96
L1306 94	L1904 98	L2502 102	L3005 106	L3706 95	L4604 118	L8106 94	L8704 96
L1402 96	L1905 98	L2503 102	L3006 106	L3802 118	L4701 118	L8202 94	L8705 96
L1403 96	L1906 98	L2504 102	L3102 106	L3803 118	L4702 118	L8203 94	L8706 96
L1404 96	L2002 98	L2505 102	L3103 106	L3804 118	L4703 118	L8204 94	M0110 74
L1405 96	L2003 98	L2506 102	L3104 106	L3805 118	L4704 118	L8205 94	M0210 74
L1406 96	L2004 98	L2602 104	L3105 106	L3902 118	L4800 122	L8206 94	M0310 75
L1502 96	L2005 98	L2603 104	L3106 106	L3903 118	L4900 122	L8302 94	M0410 75
L1503 96	L2006 98	L2604 104	L3202 106	L3904 118	L5000 85	L8303 94	M1112 80
L1504 96	L2102 98	L2605 104	L3203 106	L3905 118	L5100 85	L8304 94	M1212 80
L1505 96	L2103 98	L2606 104	L3204 106	L4000 110	L6200 87	L8305 94	M1512 80
L1506 96	L2104 98	L2702 104	L3205 106	L4100 110	L6201 87	L8306 94	M1612 80
L1602 96	L2105 98	L2703 104	L3206 106	L4203 112	L6300 87	L8402 96	M3010 85
L1603 96	L2106 98	L2704 104	L3302 106	L4204 112	L6301 87	L8403 96	M3110 85
L1604 96	L2202 102	L2705 104	L3303 106	L4206 112	L7000 87	L8404 96	M3210 85
L1605 96	L2203 102	L2706 104	L3304 106	L4303 112	L7001 87	L8405 96	M3310 85
L1606 96	L2204 102	L2802 104	L3305 106	L4304 112	L7002 87	L8406 96	
L1702 96	L2205 102	L2803 104	L3306 106	L4306 112	L7100 87	L8502 96	
L1703 96	L2206 102	L2804 104	L3404 95	L4406 114	L7101 87	L8503 96	

PRODUCT NAME INDEX

Ambiance L73	11	Ice X161	55	Quinta C100 Square D Dir	21	Trimless VP X124 Lens W	47
Ambiance L73 Directional	11	Ikon	132	Quinta C100 Square Fixed	20	Trimless VP X140	48
Ambiance L73 Kick W	12	Jazz X100 Directional	17	Square X161	56	Trimless VP X140 Directional	49
Ambiance L74	12	Jazz X110 Directional	17	Square X161 Directional	57	Trimless VP X140 Lens W	49
Ambiance X100	13	LEDEX S	142	Square X161 Lens Wallwash	57	Trimless VP X140 Kick W	48
Ambiance X100 Directional	13	LEDEX R	143	Surface VP X140	62	VP X73	29
Ambiance X100 Lens W	14	LEDEX SP	143	Surface VP X140 Directional	63	VP X73 Kick Wallwasher	29
Ambiance L100	14	Lightline LED 60 Dir / Ind	95	Surface VP X140 Kick W	62	VP X100	30
Ambiance L100 Directional	15	Lightline LED 60 Surface	94	Surface VP X161	63	VP X100 Kick Wallwasher	30
Ambiance L100 Lens W	15	Lightline LED 60 R Trim	96	Surface VP X161 Kick W	65	VP X100 Directional	31
Ambiance Square X70	23	Lightline LED 60 Trimless	98	Tempo X161	52	VP X143	33
Ambiance Square X100	23	Lightline LED 88 Surface	102	Tempo X161 80°	53	VP X143 Kick W	33
Ampia X161	54	Lightline LED 88 R Trim	104	Tempo X161 Lens W	54	VP X143 Directional	34
Atelier Frame Square	74	Lightline LED 88 Trimless	106	Terra LED 150	122	VP X143 Double Wallwasher	35
Atelier Frame Linear	80	Minitrim X86	16	Trimless Ambiance X53 Sq	41	VP X143 Corner Wallwasher	35
Atelier Panel Square	85	Minitrim X86 Directional	16	Trimless Ambiance X80 Sq	41	VP X143 Lens Wallwasher	34
Atelier Plus Linear	87	Poppy X100	25	Trimless Ambiance X80	42	VP X161	36
Atelier Plus Square	85	Projector LED	118	Trimless Ambiance X80 Dir	43	VP X161 Kick Wallwasher	36
Baltic X	130	Quad L86 Shallow	25	Trimless Ambiance X80 Lens	42	VP X161 Lens Wallwasher	37
Bordo LED 150	110	Quad L86	24	Wallwasher	42	VP X161 Directional	37
Civic X65	60	Quad X86	24	Trimless VP X82	44	Wallwasher LED	112
Civic X102	60	Quad L86 Double	24	Trimless VP X82 Kick W	44	Waylight 3	138
Civic X102 Directional	61	Quad X86 Double	24	Trimless VP X124	45	Waylight 3 Corridor Lens	139
Civic X165	61	Quinta C100 Round Dir	18	Trimless VP X124 Corner W	46	Waylight 3 Open Area Lens	139
Civic G210	65	Quinta C100 Round D Dir	19	Trimless VP X124 Directional	47	Waylight 3 Round Surface	140
Coveline	114	Quinta C100 Round Fixed	18	Trimless VP X124 Double W	46	Waylight 3 Square Surface	141
Grazer	118	Quinta C100 Square Dir	20	Trimless VP X124 Kick W	45		

The Heal's Building,
Tottenham Court Road/Alfred Mews, London
Building Services Consultant: Cundall
Architects: John McAslan + Partners
Photograph: Courtesy of LUX Magazine



[www.Twitter.com
@DAL_Ltd](https://www.twitter.com/DAL_Ltd)



[www.Facebook.com
Designed Architectural Lighting Ltd](https://www.facebook.com/DesignedArchitecturalLightingLtd)



www.dal-uk.com



sales@dal-uk.com

London Studio, 48 Britton Street
London EC1M 5UL

T +44 (0)7490 3998